

RailStar motor driven trolley

- Fits wide range of beam sizes for maximum versatility
- For use with hook suspended single speed hoists that are equipped with reversing contactor
- Steel plate side frames
- Steel spur gearing for optimum strength and smooth operation
- Durable hardened cast iron trackwheels that operate on standard S-beams or flat flanged beams
- Lifetime lubricated double row ball bearings for high efficiency, low maintenance
- Cast iron control enclosure
- Four-button control station included for operating single speed hoist proportioned to 20 ft. lift
- Trolley guards standard
- 115 volt control circuit
- One-year warranty
- Imported

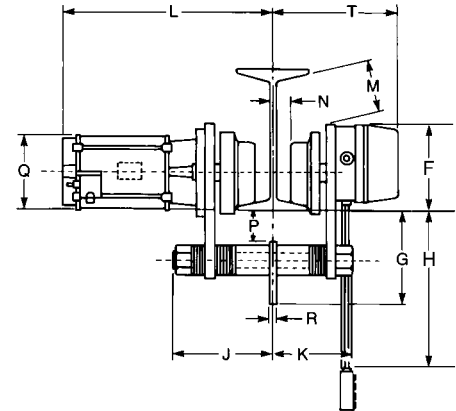
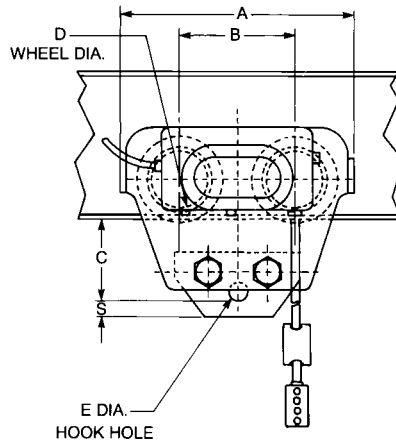

Clearance dimensions (in.)

Dimension	Rated capacity* (tons)	
	1/8-2	3
Min. radius curve	52	71
Beam range	S6x12.5-S18x54.7	S8x18.4-S24x79.9
A	12 ³ / ₄	14 ¹ / ₈
B	6 ³ / ₈	6 ³ / ₄
C**	4 ¹³ / ₁₆	5 ¹ / ₄
D	3 ⁹ / ₁₆	3 ¹⁵ / ₁₆
E	2 ⁹ / ₁₆	2 ¹⁵ / ₁₆
F**	4 ³ / ₄	5 ³ / ₁₆
G**	6	6 ⁹ / ₁₆
H**	17 ft.	17 ft.
J	7 ¹ / ₂	9 ⁹ / ₁₆
K	4 ¹ / ₈	4 ¹ / ₁₆
SINGLE PHASE L	12 ³ / ₄	15 ³ / ₁₆
THREE PHASE L	11 ⁷ / ₁₆	13 ⁷ / ₈
M**	1 ¹ / ₂	2 ¹⁵ / ₁₆
N**	3/8	3/4
P**	1 ⁷ / ₁₆	1 ⁹ / ₁₆
Q**	5 ¹ / ₈	5 ⁷ / ₈
R	1/2	3/4
S	1 ¹ / ₁₆	1 ¹ / ₁₆
T**	8 ⁷ / ₈	9 ⁹ / ₁₆



Authorized Sales & Service
J. HERBERT CORPORATION
 Call 1-800-255-0588
 407-846-0588 Fax: 846-1066
 info@jherbertcorp.com

Visit us online:
www.jherbertcorp.com

**Dimensions given are for minimum S-beam and will vary with larger beams.

Specifications

Rated capacity* (tons)	Product code	Operating voltage		Phase	Travel speed		Motor H.P.	Min. beam size	Max. beam size	Shipping weight (lbs.)
		50 hertz	60 hertz		50 hertz (F.P.M.)	60 hertz (F.P.M.)				
1/8-2	0300	220/380-415	220-240/440-480	3	65	78	1/3	S6x12.5	S18x54.7	108
1/8-2	0301	n/a	110-120	1	n/a	78	1/3	S6x12.5	S18x54.7	113
3	0302	220/380-415	220-240/440-480	3	65	78	3/4	S8x18.4	S24x79.9	185
3	0303	n/a	110-120	1	n/a	78	3/4	S8x18.4	S24x79.9	190

Note: Three phase units are reconnectable for high and low range voltage