

# Grabs & Tongs



## Model 74 - Barrier Grabs



### PRODUCT FEATURES:

- Hands-off operation. No need to attach and secure lifting chains or slings.
- The barrier suffers far less damage when moving. This means longer barrier life and reduced cost.
- The grab is able to move barriers quicker and easier than manual methods, resulting in less man-hours.
- There is no need to drill holes in the barriers to accommodate chains or slings.
- Replaceable urethane lifting pads are standard.
- Designed and manufactured to ASME B30.20.

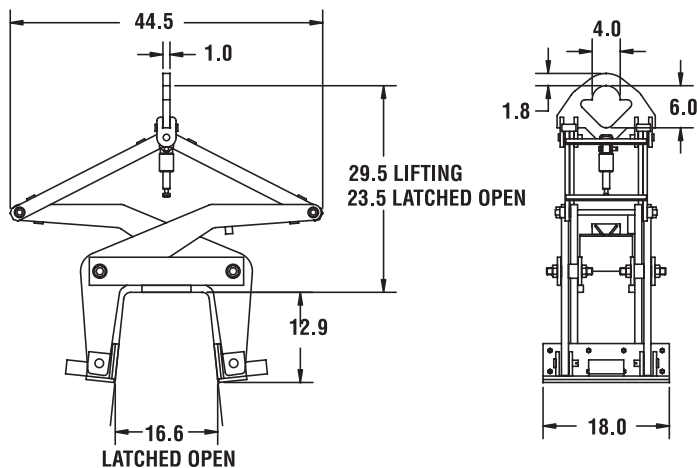

### SPECIFICATIONS

Model Number	Rated Capacity (lbs.)	Weight (lbs.)
74-4 1/4	8,500	452
74-7 1/4	14,500	517

Note: States of CA, OR & WA may require special grips with steel "Dog Points" in lieu of standard pads. Specify "Dog Points" with order.

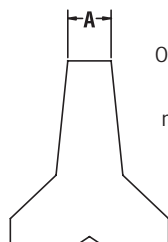

Our standard Barrier Grab will handle 6"-12" nominal width at the top ("A" dimension).

## Operation

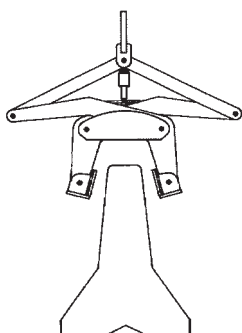

Tong is placed on load in open position. Hoist line must be slack for auto-latch to disengage.

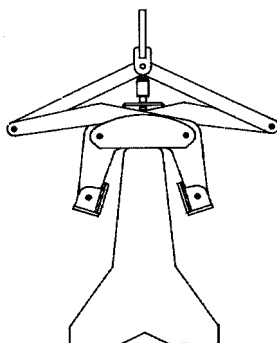

Crane hook is then raised allowing pads to engage barrier.

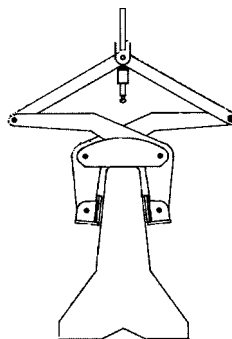

Barrier is placed in position. Hoist line must be slack for auto-latch to engage.

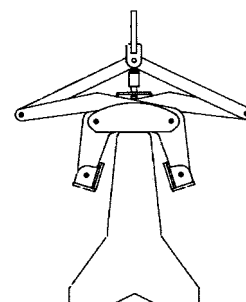

With auto-latch engaged, grab is held open to allow lifting and placement of next barrier.

# Grabs & Tongs



## Model 74 - Barrier Grabs

### Optional Extended Barrier Grab Kit



#### PRODUCT FEATURES:

- Attach two Barrier Grabs, and expand your barrier handling capabilities.
- Handles barriers up to 40' in length.
- Beams can be used for other material handling applications when Barrier Grabs are removed.
- Single auto-latch for extended unit allows for smooth operation.

**74-4 1/4-E Kit**  
Entire Unit Rated  
Capacity: 17,000 lbs

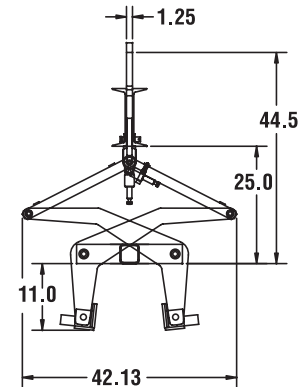
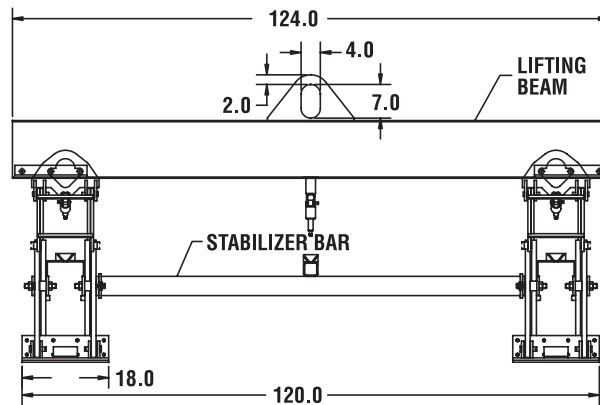

**74-7 1/4 E Kit**  
Entire Unit Rated  
Capacity: 29,000 lbs

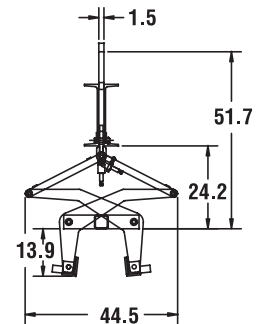
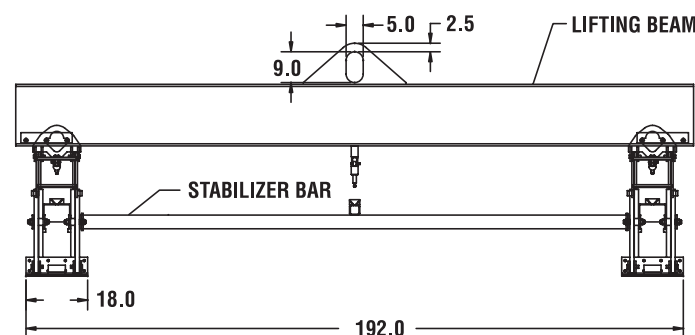

#### BARRIER GRABS MUST BE PURCHASED SEPARATELY

Each kit consists of:

- 1 - Model 20 lifting beam, with Autolatch lug welded in place.
- 1 - Autolatch
- 1 - Stabilizer bar
- 1 - Set of attaching hardware

# Grabs & Tongs



## Model ST - Slab Tongs



**IN-STOCK PROGRAM**

### PRODUCT FEATURES:

- Designed for lifting heavy slabs of concrete, stone or highly polished metal that must be protected from scratching or marring.
- Can be used in construction work to position slabs.
- The curved pads give proper contact for gripping smooth surfaces and handling a large range of sizes.
- Urethane gripping surfaces are standard.
- Semi-automatic latch is standard and serves as an aid in positioning the tongs for picking up the load.
- Designed and manufactured to ASME B30.20.

### SPECIFICATIONS

Model Number	Rated Capacity (lbs.)	Load Width (in.)	Dim. A (in.)	Weight (lbs.)
71 - 1	1,000	6 to 10	39	75
71 - 2	1,500	8 to 12	39	85
71 - 3	1,500	10 to 14	40	145
71 - 4	1,500	14 to 18	44	145
71 - 5	1,500	18 to 22	55	150

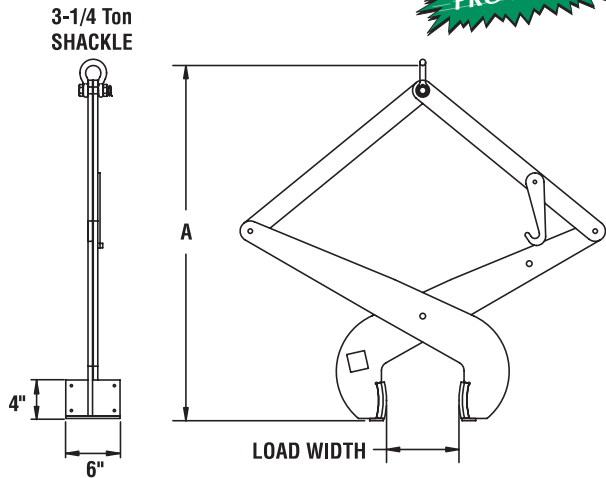

## Model RLT - Rail Tongs



**IN-STOCK PROGRAM**

### PRODUCT FEATURES:

- Rail Tongs are designed to handle all standard size rails.
- Tongs are provided with non-slip machined diamond face gripping pad.
- Load must be balanced and controlled when lifting.
- Designed and manufactured to ASME B30.20.

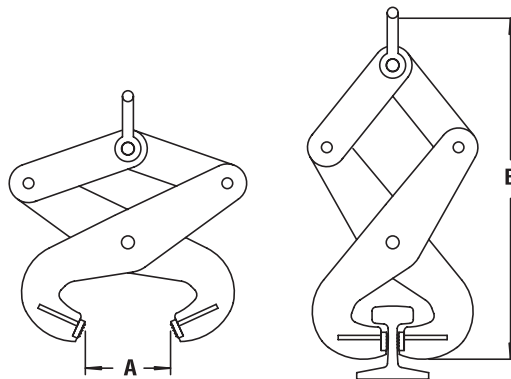

### SPECIFICATIONS

Model Number	Rated Capacity in Tons	A (in.)	B (in.)	Weight (lbs.)
109 - 1	1	3	18	15
109 - 2	2	5	20	18

# Grabs & Tongs



## Model VDG - Vertical Drum Grab



### PRODUCT FEATURES:

- This vertical drum grab is ideal for handling closed or open steel drums.
- No fasteners, binders, or rings to put around drum.
- Grab allows drums to be closely stored maximizing floor space.
- Grab will not damage drum.
- Designed and manufactured to ASME B30.20

**IN-STOCK PROGRAM**

### SPECIFICATIONS

Model Number	Rated Capacity in Tons	Weight (lbs.)
150 - 1	1	19

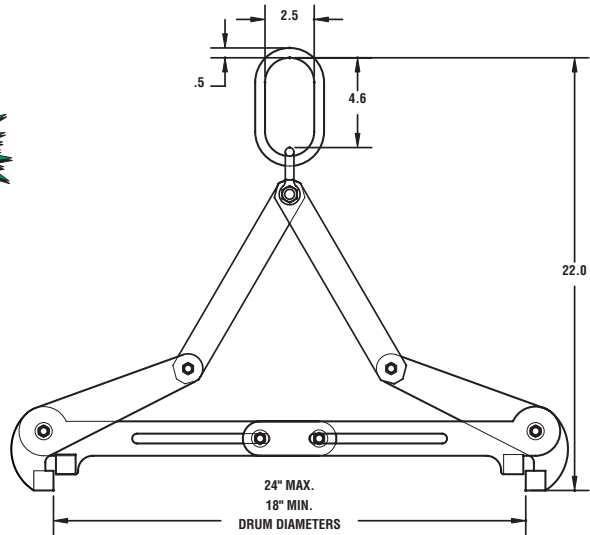

## Operation



1. Lower grab on to top of drum.



2. Grab takes hold under rim.  
(Not automatic)



3. Lift drum.

Authorized Sales & Service  
**J. HERBERT CORPORATION**  
 Call 1-800-255-0588  
 407-846-0588 Fax: 846-1066  
 info@jherbertcorp.com  
 Visit us online:  
 www.jherbertcorp.com