



## Model D - Twin Crossarms with 4 Pads Vacuum Lifter

For lifting wide or thin material. The crossarms make the load easier to balance.

Quick guideline for max. sheet size of steel or aluminum at different thicknesses.

Minimum Thickness (in.)	Maximum Width (in.)	Maximum Length (in.)
.0250	72	72
.0478	96	96
.1150	96	144
.1950	96	192

Max. width equal to twice overhang distance.  
 Max. length equal to four times overhang distance.

**NOTE:** All venturi units include a side handle.  
 For other options, please see page C.8.

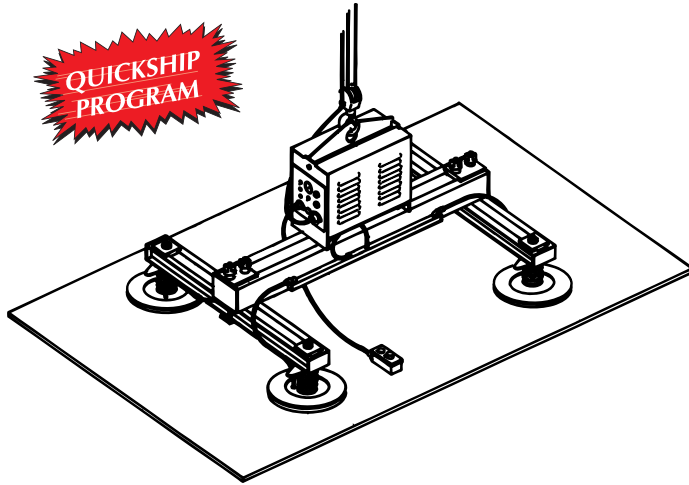

### SPECIFICATIONS

Add FEET to blank Model Number box to complete code.  
 Example: 5' load beam - DA16V8  5  D3

Rated Capacity (lbs.)	Base Wt. @ 5' (lbs.)	Model Number	Power-Pac	Flared Diameter (in.)	Load Beam Length (ft.)		
					5	6	8
<b>Shop Air - Venturi</b>							
<b>With 3' Crossarm Beams</b>							
680	315	DA6S6 <input type="checkbox"/> D3	V-40	7-1/4	5	6	8
1240	315	DA12S8 <input type="checkbox"/> D3	V-40	9-5/8	5	6	8
1600	320	DA16V8 <input type="checkbox"/> D3	V-40	10-5/8	5	6	8
2400	335	DA24V10 <input type="checkbox"/> D3	V-40	12-1/4	5	6	8
3200	355	DA32V12 <input type="checkbox"/> D3	V-40	14-1/4	5	6	8
4000	380	DA40V14 <input type="checkbox"/> D3	V-40	16	5	6	8
<b>With 4' Crossarm Beams</b>							
680	325	DA6S6 <input type="checkbox"/> D4	V-40	7-1/4	5	6	8
1240	325	DA12S8 <input type="checkbox"/> D4	V-40	9-5/8	5	6	8
1600	330	DA16V8 <input type="checkbox"/> D4	V-40	10-5/8	5	6	8
2400	345	DA24V10 <input type="checkbox"/> D4	V-40	12-1/4	5	6	8
3200	365	DA32V12 <input type="checkbox"/> D4	V-40	14-1/4	5	6	8
4000	390	DA40V14 <input type="checkbox"/> D4	V-40	16	5	6	8
<b>Electric</b>							
<b>With 3' Crossarm Beams</b>							
680	290	DE6S6 <input type="checkbox"/> D3	UNIVAC-250	7-1/4	5	6	8
1240	310	DE12S8 <input type="checkbox"/> D3	UNIVAC-250	9-5/8	5	6	8
1600	350	DE16V8 <input type="checkbox"/> D3	UNIVAC-250	10-5/8	5	6	8
2400	365	DE24V10 <input type="checkbox"/> D3	UNIVAC-250	12-1/4	5	6	8
3200	485	DE32V12 <input type="checkbox"/> D3	UNIVAC-330	14-1/4	5	6	8
4000	520	DE40V14 <input type="checkbox"/> D3	UNIVAC-330	16	5	6	8
6000	535	DE60V16 <input type="checkbox"/> D3	UNIVAC-330	19	5	6	8
8000	970	DE80V20 <input type="checkbox"/> D3	UNIVAC-1500	23	5	6	8
<b>With 4' Crossarm Beams</b>							
680	300	DE6S4 <input type="checkbox"/> D4	UNIVAC-250	7-1/4	5	6	8
1240	315	DE12S8 <input type="checkbox"/> D4	UNIVAC-250	9-5/8	5	6	8
1600	360	DE16V8 <input type="checkbox"/> D4	UNIVAC-250	10-5/8	5	6	8
2400	375	DE24V10 <input type="checkbox"/> D4	UNIVAC-250	12-1/4	5	6	8
3200	495	DE32V12 <input type="checkbox"/> D4	UNIVAC-330	14-1/4	5	6	8
4000	520	DE40V14 <input type="checkbox"/> D4	UNIVAC-330	16	5	6	8
6000	545	DE60V16 <input type="checkbox"/> D4	UNIVAC-330	19	5	6	8
8000	980	DE80V20 <input type="checkbox"/> D4	UNIVAC-1500	23	5	6	8

Other sizes available, consult factory.

# Wide Applications

## Model D - Twin Crossarms with 4 Pads Vacuum Lifter



Lightweight Univac® 250 for capacities less than 2,400 pounds.

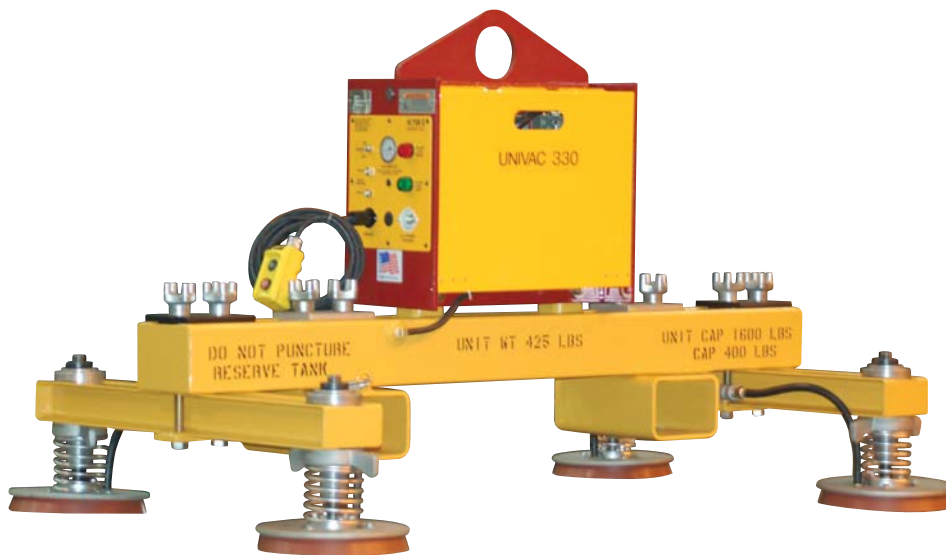

Battery powered unit with fork pockets allows lifter to be used with a lift truck.

**Crossarms allow for extra stability for wider material and reduce amount of deflection for thinner material.**



**The Caldwell Group • 800-628-4263 Fax 815-229-5686**

**UNIVAC®**  
Rev. 03/08  
Vacuum Lifters Section  
Master Catalog MC-607

# Wide Applications

## Model E - Triple Crossarms with 6 Pads Vacuum Lifter

For lifting semi long and wide material of moderate weight, or extra support of thin material.

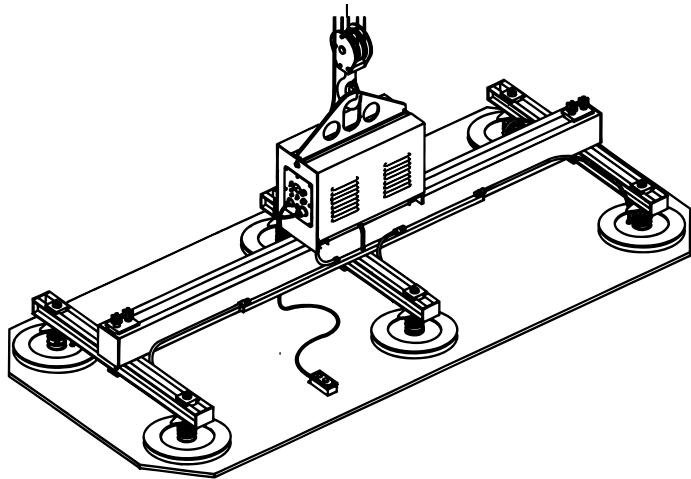

Quick guideline for max. sheet size of steel or aluminum at different thicknesses.

Minimum Thickness (in.)	Maximum Width (in.)	Maximum Length (in.)
.0250	72	96
.0478	96	144
.1150	96	216
.1950	96	270

Max. width equal to twice overhang distance.

Max. length equal to four times overhang distance.

**NOTE:** All venturi units include a side handle. For other options, please see page C.8.

### SPECIFICATIONS

Add FEET to blank Model Number box to complete code.  
Example: 5' load beam - EE24V8  T4

Rated Capacity (lbs.)	Base Wt. @ 5' (lbs.)	Model Number	Power-Pac	Flared Diameter (in.)	Load Beam Length (ft.)					
					5	6	8	10	12	15
<b>Shop Air - Venturi</b>										
<b>With 3' Crossarm Beams</b>										
480	380	EA4S4 <input type="checkbox"/> T3	V-40	5	5	6	8	10	12	15
1200	385	EA10S6 <input type="checkbox"/> T3	V-40	7-1/4	5	6	8	10	12	15
1860	400	EA18S8 <input type="checkbox"/> T3	V-40	9-5/8	5	6	8	10	12	15
2400	420	EA24V8 <input type="checkbox"/> T3	V-40	10-5/8	5	6	8	10	12	15
3600	430	EA36V10 <input type="checkbox"/> T3	V-40	12-1/4	5	6	8	10	12	15
<b>With 4' Crossarm Beams</b>										
480	390	EA4S4 <input type="checkbox"/> T4	V-40	5	5	6	8	10	12	15
1200	395	EA10S6 <input type="checkbox"/> T4	V-40	7-1/4	5	6	8	10	12	15
1860	420	EA18S8 <input type="checkbox"/> T4	V-40	9-5/8	5	6	8	10	12	15
2400	430	EA24V8 <input type="checkbox"/> T4	V-40	10-5/8	5	6	8	10	12	15
3600	440	EA36V10 <input type="checkbox"/> T4	V-40	12-1/4	5	6	8	10	12	15
<b>Electric</b>										
<b>With 3' Crossarm Beams</b>										
480	405	EE4S4 <input type="checkbox"/> T3	UNIVAC-250	5	5	6	8	10	12	15
1200	410	EE10S6 <input type="checkbox"/> T3	UNIVAC-250	7-1/4	5	6	8	10	12	15
1860	420	EE18S8 <input type="checkbox"/> T3	UNIVAC-250	9-5/8	5	6	8	10	12	15
2400	435	EE24V8 <input type="checkbox"/> T3	UNIVAC-250	10-5/8	5	6	8	10	12	15
3600	560	EE36V10 <input type="checkbox"/> T3	UNIVAC-330	12-1/4	5	6	8	10	12	15
4800	580	EE48V12 <input type="checkbox"/> T3	UNIVAC-330	14-1/4	5	6	8	10	12	15
6000	910	EE60V14 <input type="checkbox"/> T3	UNIVAC-330	16	5	6	8	10	12	15
9000	930	EE90V16 <input type="checkbox"/> T3	*UNIVAC-1500	19	5	6	8	10	12	15
12000	1216	EE120V20 <input type="checkbox"/> T3	*UNIVAC-1500	23	5	6	8	10	12	15
<b>WITH 4' CROSSARM BEAMS</b>										
480	415	EE4S4 <input type="checkbox"/> T4	UNIVAC-250	5	5	6	8	10	12	15
1200	420	EE10S6 <input type="checkbox"/> T4	UNIVAC-250	7-1/4	5	6	8	10	12	15
1860	430	EE18S8 <input type="checkbox"/> T4	UNIVAC-250	9-5/8	5	6	8	10	12	15
2400	445	EE24V8 <input type="checkbox"/> T4	UNIVAC-250	10-5/8	5	6	8	10	12	15
3600	570	EE36V10 <input type="checkbox"/> T4	UNIVAC-330	12-1/4	5	6	8	10	12	15
4800	590	EE48V12 <input type="checkbox"/> T4	UNIVAC-330	14-1/4	5	6	8	10	12	15
6000	920	EE60V14 <input type="checkbox"/> T4	UNIVAC-330	16	5	6	8	10	12	15
9000	940	EE90V16 <input type="checkbox"/> T4	*UNIVAC-1500	19	5	6	8	10	12	15
12000	1226	EE120V20 <input type="checkbox"/> T4	*UNIVAC-1500	23	5	6	8	10	12	15

\*NOTE: 230/460V

Other sizes available, consult factory.



# Wide Applications

## Model E - Triple Crossarms with 6 Pads Vacuum Lifter

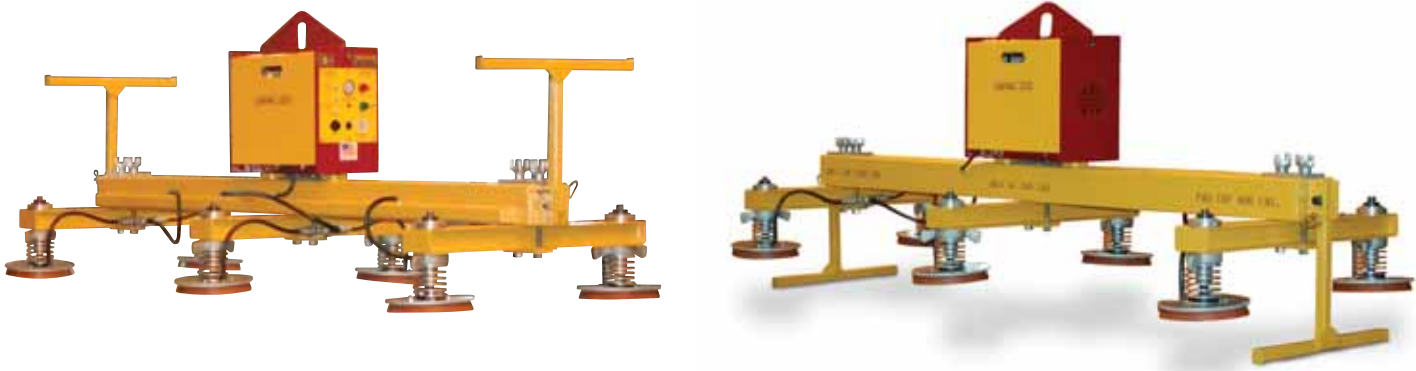

A parking stand is just one option available on all vacuum units.



Manual slide valves shut off individual crossarms allowing the operator to easily customize the lifter to match the load.

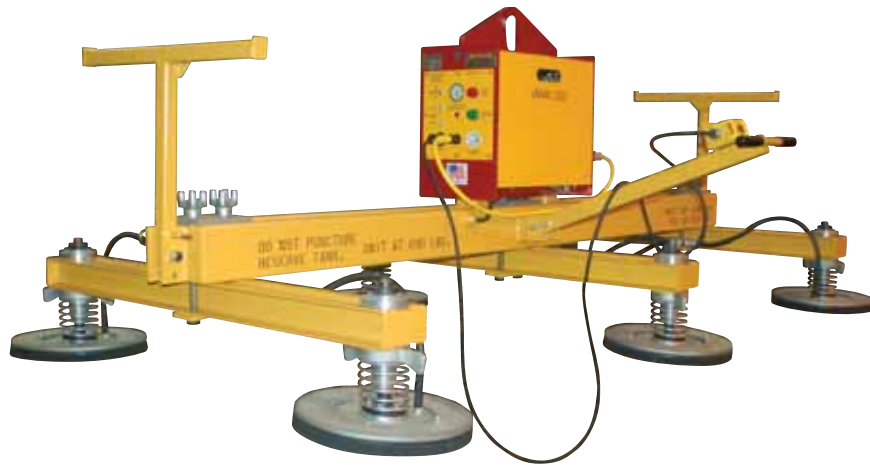

Above lifter utilizing a parking stand (option "P"), side handle (option "SH"), and transformer (option "T").



The Caldwell Group • 800-628-4263 Fax 815-229-5686

UNIVAC®  
Vacuum Lifters Section  
Master Catalog MC-607

# Wide Applications



## Model F - Quad Crossarms with 8 to 12 Pads Vacuum Lifter

For lifting longer, wider and heavier sized material, or increased support of thin material.

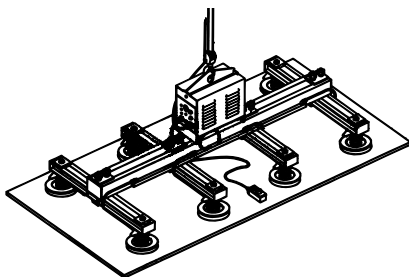

**NOTE:** All venturi units include a side handle. For other options, please see page C.8.

Quick guideline for max. sheet size of steel or aluminum at different thicknesses.

Min. Thickness (in.)	Max. Width (in.)	Max. Length (in.)
.0250	72	144
.0478	96	200
.1150	120	300
.1950	120	320

Max. width equal to four times overhang distance.  
 Max. length equal to eight times overhang distance.

### SPECIFICATIONS

Add FEET to blank Model Number box to complete code. Example: 6' load beam - FA6S4  6  Q3

Rated Capacity (lbs.)	Base Wt. @ 6' (lbs.)	Model Number	Power-Pac	Flared Diameter (in.)	Load Beam Length (ft.)					
					6	8	10	12	15	20
<b>Shop Air - Venturi</b>										
<b>With 3' Crossarm Beams</b>										
640	475	FA6S4 <input type="checkbox"/> Q3	V-40	5	6	8	10	12	15	20
1360	490	FA13S6 <input type="checkbox"/> Q3	V-40	7-1/4	6	8	10	12	15	20
2480	520	FA24S8 <input type="checkbox"/> Q3	V-40	9-5/8	6	8	10	12	15	20
3200	540	FA32V8 <input type="checkbox"/> Q3	V-40	10-5/8	6	8	10	12	15	20
<b>With 4' Crossarm Beams</b>										
640	485	FA6S4 <input type="checkbox"/> Q4	V-40	5	6	8	10	12	15	20
1360	500	FA13S6 <input type="checkbox"/> Q4	V-40	7-1/4	6	8	10	12	15	20
2480	530	FA24S8 <input type="checkbox"/> Q4	V-40	9-5/8	6	8	10	12	15	20
3200	550	FA32V8 <input type="checkbox"/> Q4	V-40	10-5/8	6	8	10	12	15	20
<b>With 5' Crossarm Beams</b>										
640	495	FA6S4 <input type="checkbox"/> Q5	V-40	5	6	8	10	12	15	20
1360	510	FA13S6 <input type="checkbox"/> Q5	V-40	7-1/4	6	8	10	12	15	20
2480	540	FA24S8 <input type="checkbox"/> Q5	V-40	9-5/8	6	8	10	12	15	20
3200	560	FA32V8 <input type="checkbox"/> Q5	V-40	10-5/8	6	8	10	12	15	20
<b>Electric</b>										
<b>With 3' Crossarm Beams</b>										
640	525	FE6S4 <input type="checkbox"/> Q3	UNIVAC-250	5	6	8	10	12	15	20
1360	530	FE13S6 <input type="checkbox"/> Q3	UNIVAC-250	7-1/4	6	8	10	12	15	20
2480	540	FE24S8 <input type="checkbox"/> Q3	UNIVAC-250	9-5/8	6	8	10	12	15	20
3200	670	FE32V8 <input type="checkbox"/> Q3	UNIVAC-330	10-5/8	6	8	10	12	15	20
4800	700	FE48V10 <input type="checkbox"/> Q3	UNIVAC-330	12-1/4	6	8	10	12	15	20
6400	735	FE64V12 <input type="checkbox"/> Q3	UNIVAC-330	14-1/4	6	8	10	12	15	20
8000	795	FE80V14 <input type="checkbox"/> Q3	UNIVAC-330	16	6	8	10	12	15	20
12000	1260	FE120V16 <input type="checkbox"/> Q3	*UNIVAC-1500	19	6	8	10	12	15	20
15200	1490	FE152V20 <input type="checkbox"/> Q3	*UNIVAC-1500	23	—	8	10	12	15	20
<b>With 4' Crossarm Beams</b>										
640	535	FE6S4 <input type="checkbox"/> Q4	UNIVAC-250	5	6	8	10	12	15	20
1360	540	FE13S6 <input type="checkbox"/> Q4	UNIVAC-250	7-1/4	6	8	10	12	15	20
2480	550	FE24S8 <input type="checkbox"/> Q4	UNIVAC-250	9-5/8	6	8	10	12	15	20
3200	680	FE32V8 <input type="checkbox"/> Q4	UNIVAC-330	10-5/8	6	8	10	12	15	20
4800	710	FE48V10 <input type="checkbox"/> Q4	UNIVAC-330	12-1/4	6	8	10	12	15	20
6400	745	FE64V12 <input type="checkbox"/> Q4	UNIVAC-330	14-1/4	6	8	10	12	15	20
8000	810	FE80V14 <input type="checkbox"/> Q4	UNIVAC-330	16	6	8	10	12	15	20
12000	1270	FE120V16 <input type="checkbox"/> Q4	*UNIVAC-1500	19	6	8	10	12	15	20
15200	1500	FE152V20 <input type="checkbox"/> Q4	*UNIVAC-1500	23	—	8	10	12	15	20
<b>With 5' Crossarm Beams</b>										
640	545	FE6S4 <input type="checkbox"/> Q5	UNIVAC-250	5	6	8	10	12	15	20
1360	550	FE13S6 <input type="checkbox"/> Q5	UNIVAC-250	7-1/4	6	8	10	12	15	20
2480	570	FE24S8 <input type="checkbox"/> Q5	UNIVAC-250	9-5/8	6	8	10	12	15	20
3200	690	FE32V8 <input type="checkbox"/> Q5	UNIVAC-330	10-5/8	6	8	10	12	15	20
4800	720	FE48V10 <input type="checkbox"/> Q5	UNIVAC-330	12-1/4	6	8	10	12	15	20
6400	755	FE64V12 <input type="checkbox"/> Q5	UNIVAC-330	14-1/4	6	8	10	12	15	20
8000	820	FE80V14 <input type="checkbox"/> Q5	UNIVAC-330	16	6	8	10	12	15	20
12000	1280	FE120V16 <input type="checkbox"/> Q5	*UNIVAC-1500	19	6	8	10	12	15	20
15200	1510	FE152V20 <input type="checkbox"/> Q5	*UNIVAC-1500	23	—	8	10	12	15	20



# Wide Applications

## Model F - Quad Crossarms with 8 to 12 Pads Vacuum Lifter

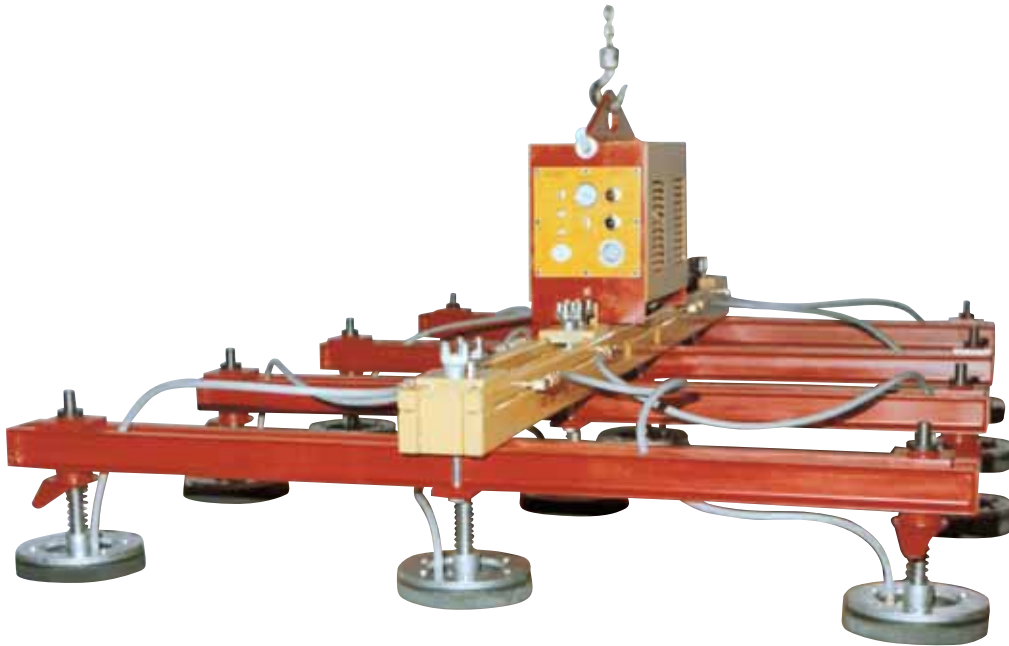

Sponge vacuum pads used to handle rough material such as tread plate or OSB (particle board).



Crossarms are adjustable along load beam, and pads can be adjusted along the crossarms providing maximum flexibility.



**The Caldwell Group** • 800-628-4263 Fax 815-229-5686

UNIVAC®  
Vacuum Lifters Section  
Master Catalog MC-607

# Application Evaluation



The Caldwell Group • 800-628-4263 Fax 815-229-5686

UNIVAC®  
Vacuum Lifters Section  
Master Catalog MC-607

## Univac® Application Evaluation

### Material To Be Handled:

- Steel
- Aluminum
- Glass
- Stone Slabs
- Plastic/Fiberglass
- Particle Board
- Other: \_\_\_\_\_ (Provide detailed sketch)

### Material Temperature Is:

- Under 200° F
- 200° to 600° F
- Over 600° F (Specify temperature)

### Material Dimensions:

Minimum: Length \_\_\_\_\_ Width \_\_\_\_\_ Thickness \_\_\_\_\_ (required)  
Maximum: Length \_\_\_\_\_ Width \_\_\_\_\_ Thickness \_\_\_\_\_  
Maximum Capacity Required \_\_\_\_\_

### Material Orientation During Lift:

- Horizontal Only
- Vertical Only
- Horizontal to Vertical

Headroom Available: \_\_\_\_\_

### Power Available:

- Electric Specify:
  - 115v/1ph/60hz
  - 230-460v/3ph/60hz
  - 230v dc
- Compressed Air
- No External Power - Battery operated required

### Hook Size or Hook Opening:

Required for crane hook

H \_\_\_\_\_  
O \_\_\_\_\_  
W \_\_\_\_\_

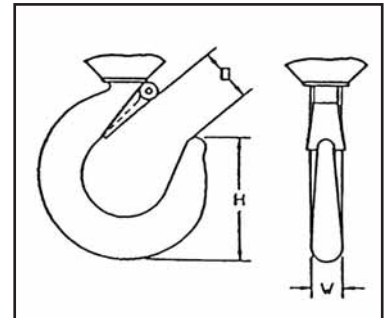

### Options Required:

- Side Handle
- Parking Stand
- Audible Low Vacuum Warning
- Custom Pendant Control (Standard is 2-button)
- Wireless Pendant Control

*Authorized Sales & Service*  
**J. HERBERT CORPORATION**  
Call 1-800-255-0588  
407-846-0588 Fax: 846-1066  
info@jherbertcorp.com  
**Visit us online:**  
www.jherbertcorp.com

For a price quote on your specific application, please complete the above application guide and fax this along with a photo, sketch, or drawing of the product being rotated, to **815-229-5686**