

# Five Seals Protect Internal Components



**3/4 - 6 Ton**  
Made in USA

## MA and MAL Ratchet Lever Hoists

**COFFING MA and MAL Models** - Survive the toughest environments to provide safe, secure load control. Five seals (exclusive to the MA and MAL) increase the life of the hoist by protecting the gears and the brake mechanism from contamination by oil, grease, dirt, water, and other environmental hazards (see page 37). The MA and MAL are ideal for construction, industrial, and maintenance applications which require a brake for precise positioning or to disengage the tension on the load.

- **CAPACITIES & LIFT** - Rated loads from 3/4 to 6 Tons, with 5-foot standard lift. Other lifts available.
- **RUGGED** - Unit and handle made from high strength ductile aluminum alloy for corrosion resistance and portability.
- **FREE CHAINING MECHANISM** - Allows quick and easy one-handed take-up and positioning of slack chain. Will not accidentally free chain when under load.
- **FIVE SEALS** - Keep the brake mechanism clean and dry, so braking performance remains consistent even under severe exposure conditions.
- **LOAD LIMITER (MAL Models)** - See page 37.
- **PRECISE LOAD POSITIONING** - Screw and disc brake lowering allows “micro-inching” for load spotting within fractions of an inch.
- **HANDLE STOPS** - Keep handle from spinning in case operator’s hand accidentally slips off the handle.
- **TOP SLING MODELS** - Allow secure fastening around posts, beams, and other anchor points for easy rigging. MAR model has 30” sling with grab hook.
- **OPTIONS** - Bullard hooks, bronze hooks, zinc-plated hooks, and zinc-plated chain - consult factory.
- **LIFETIME WARRANTY**

### S P E C I F I C A T I O N S

### MA / MAL Ratchet Lever Hoists

Capacity		Model Number *	Strands of Load Chain	Minimum Distance Between Hooks (In.)	Handle Length (In.)	Minimum Lifting Increment (In.) †	Average Handle Effort (Lbs.)	Net Weight (Lbs.) ††
Lbs.	Tons							
1500	3/4	MA(L)-15	1	12 <sup>7</sup> / <sub>8</sub>	20 <sup>1</sup> / <sub>2</sub>	.188	61	14 <sup>1</sup> / <sub>4</sub>
2000	1	MA(L)-20	1	12 <sup>7</sup> / <sub>8</sub>	20 <sup>1</sup> / <sub>2</sub>	.188	81	14 <sup>1</sup> / <sub>4</sub>
3000	1 <sup>1</sup> / <sub>2</sub>	MA(L)-15-2	2	17	20 <sup>1</sup> / <sub>2</sub>	.094	61	20 <sup>1</sup> / <sub>4</sub>
3000	1 <sup>1</sup> / <sub>2</sub>	MA(L)-30	1	15	20 <sup>1</sup> / <sub>2</sub>	.088	82	23
4000	2	MA(L)-40	1	15	20 <sup>1</sup> / <sub>2</sub>	.088	109	23
6000	3	MA(L)-30-2	2	18 <sup>3</sup> / <sub>4</sub>	20 <sup>1</sup> / <sub>2</sub>	.044	87	36
9000	4 <sup>1</sup> / <sub>2</sub>	MA(L)-30-3	3	23 <sup>1</sup> / <sub>8</sub>	20 <sup>1</sup> / <sub>2</sub>	.029	90	53
12000	6	MA(L)-30-4	4	22	20 <sup>1</sup> / <sub>2</sub>	.022	93	63

\* Designate MAL model number for load limiter option. Designate MAR for 30" top sling with grab hook. Longer slings available.

† Minimum increment in lowering position is infinitesimal.

†† Add approximately 2 Lbs. for MAL version.

**NOTE:** For complete dimensional data, refer to Coffing Dimensional Databook.

**MA MAL** 3/4 - 6 Ton

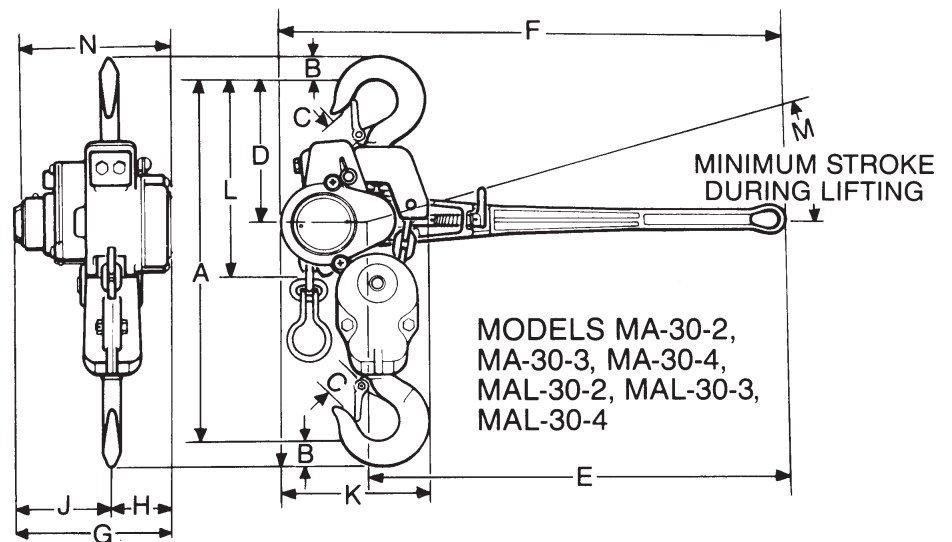
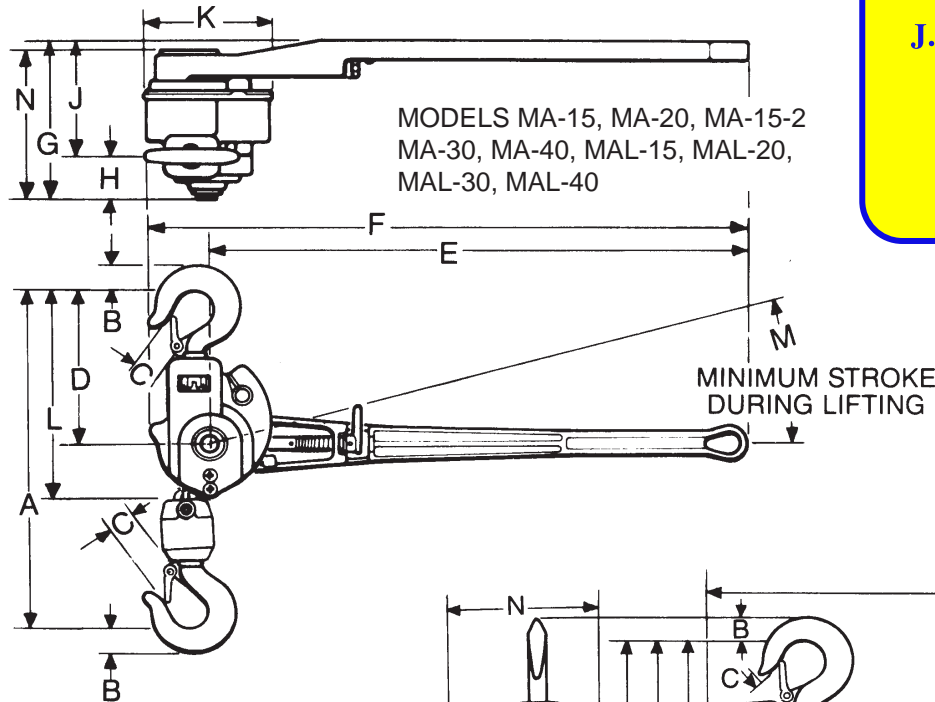

*Authorized Sales & Service*  
**J. HERBERT CORPORATION**  
Call 1-800-255-0588  
407-846-0588 Fax: 846-1066  
info@jherbertcorp.com  
  
Visit us online:  
www.jherbertcorp.com

**Dimensions**

Model Number	Rated Load		A	B	C*	D	E	F	G	H	J	K	L	M	N
	(Lbs.)	(Ton)													
MA-15	1500	3/4	127/8	1	1	61/8	20 1/2	227/8	61/8	15/8	4 1/2	45/8	8 1/2	15°	57/8
MA-20	2000	3/4	127/8	1	1	61/8	20 1/2	227/8	61/8	15/8	4 1/2	45/8	8 1/2	15°	57/8
MA-15-2	3000	1 1/2	17	1	1	7 1/4	20 1/2	235/8	6 1/8	15/8	4 1/2	55/8	9 3/4	15°	57/8
MA-30	3000	1 1/2	15	1 1/8	1 1/8	7 3/8	20 1/2	243/4	7 1/2	27/8	45/8	6 1/4	97/8	15°	73/16
MA-40	4000	1 1/2	15	1 1/8	1 1/8	7 3/8	20 1/2	243/4	7 1/2	27/8	45/8	6 1/4	97/8	15°	73/16
MA-30-2	6000	2	18 3/4	17/16	11 1/16	77/16	20 1/2	243/4	7 1/2	27/8	45/8	7 1/4	10 3/16	15°	73/16
MA-30-3	9000	4 1/2	23 1/8	113/16	11 1/16	85/16	20 1/2	243/4	7 1/2	27/8	45/8	8 1/8	11 1/16	15°	73/16
MA-30-4	12000	6	22	113/16	11 1/16	8 1/2	20 1/2	243/4	7 1/2	27/8	45/8	9 3/4	11	15°	73/16
MAL-15	1500	3/4	127/8	1	1	61/8	20 1/2	227/8	7	15/8	53/8	45/8	8 1/2	15°	7
MAL-20	2000	3/4	127/8	1	1	61/8	20 1/2	227/8	7	15/8	53/8	45/8	8 1/2	15°	7
MAL-30	3000	1 1/2	15	1 1/8	1 1/8	7 3/8	20 1/2	243/4	8 3/8	27/8	5 1/2	6 1/4	97/8	15°	85/16
MAL-40	4000	1 1/2	15	1 1/8	1 1/8	7 3/8	20 1/2	243/4	8 3/8	27/8	5 1/2	6 1/4	97/8	15°	85/16
MAL-30-2	6000	2	18 3/4	17/16	11 1/16	77/16	20 1/2	243/4	8 3/8	27/8	5 1/2	7 1/4	10 3/16	15°	85/16
MAL-30-3	9000	4 1/2	23 1/8	113/16	11 1/16	85/16	20 1/2	243/4	8 3/8	27/8	5 1/2	8 1/8	11 1/16	15°	85/16
MAL-30-4	12000	6	22	113/16	11 1/16	8 1/2	20 1/2	243/4	8 3/8	27/8	5 1/2	9 3/4	11	15°	85/16

\* Hook throat opening with latch.

**Note:** Where clearance dimensions are critical, request certified print.  
All dimensions are in inches unless otherwise indicated.