

Smooth, Reliable Operation

MT Motorized Trolley



1/4 - 5 Ton
Made in USA

COFFING MT Model Trolley - Features rugged construction with wrap-around side plates and heat treated wheels for reliable service. Universal clevis allows quick mounting of most hook mounted electric chain hoists.

- **CAPACITIES** - Rated loads from 1/4 to 5 Tons. Push button drop is 6-feet.
- **VOLTAGES** - 115/230, 208 - single phase; 230/460, 208, 220/380, 575 - three phase. 60 hertz standard, 50 hertz available.
- **SPEEDS** - 35 and 75 FPM speeds standard with optional speeds of 18, 24, 50, 100, and 150 FPM.
- **TWO-SPEED MODELS** - Optional with 3 to 1 speed ratio, three-phase, single voltage only. Slow speed feature for gentler start and greater positioning accuracy.
- **MOUNTING** - Universal clevis will accept top hook models. Can change EC and ELC suspensions to lug mount directly to MT trolley — consult factory.
- **TROLLEY DESIGN** - 4-wheel design on 1/4 - 3 Ton and under. 8-wheel design on 4 and 5-Ton for reduced beam flange stresses. Specify track type and beam size.
- **NEMA 3R PUSH BUTTON** - Ergonomic design fits operator's hand for thumb or two-handed operation. 24 Volt Control standard for operator safety. 115 Volt Control available upon request.
- **ACCESSORIES** - Trolley brake and other options available to meet a variety of applications.
- **LIFETIME WARRANTY**

SPECIFICATIONS

MT Electric Trolleys

Capacity		Model Number	Motor HP	Flange Width (In.)	Beam Ht. (In.)	Min. Rad. Curve (In.)	Net Wt. (Lb.)
(Lb.)	(Ton)						
500	1/4	MT-05035	1/4	3.332 - 6	6 - 18	48	115
500	1/4	MT-05075	1/4	3.332 - 6	6 - 18	48	115
1000	1/2	MT-10035	1/4	3.332 - 6	6 - 18	48	115
1000	1/2	MT-10075	1/4	3.332 - 6	6 - 18	48	115
2000	1	MT-20035	1/4	3.332 - 6	6 - 18	48	115
2000	1	MT-20075	1/4	3.332 - 6	6 - 18	48	115
3000	1 1/2	MT-30035	1/4	3.332 - 6	6 - 18	48	115
3000	1 1/2	MT-30075	1/4	3.332 - 6	6 - 18	48	115
4000	2	MT-40035	1/4	3.332 - 6	6 - 18	48	115
4000	2	MT-40075	1/2	3.332 - 6	6 - 18	48	115
6000	3	MT-60035	1/4	3.332 - 6	6 - 18	48	115
6000	3	MT-60075	1/2	3.332 - 6	6 - 18	48	115
8000	4	MT-80035	(2) 1/4	4 - 6	8 - 18	***	220
8000	4	MT-80075	(2) 1/2	4 - 6	8 - 18	***	220
10000	5	MT-100035	(2) 1/4	4 - 6	8 - 18	***	220
10000	5	MT-100075	(2) 1/2	4 - 6	8 - 18	***	220

*** 4 & 5 Ton - straight track only. Articulated model for 48" min. radius curved track available — consult factory.

NOTE: For complete dimensional data, refer to Coffing Dimensional Databook.

MT 1/4 - 2 Ton Motorized Trolleys

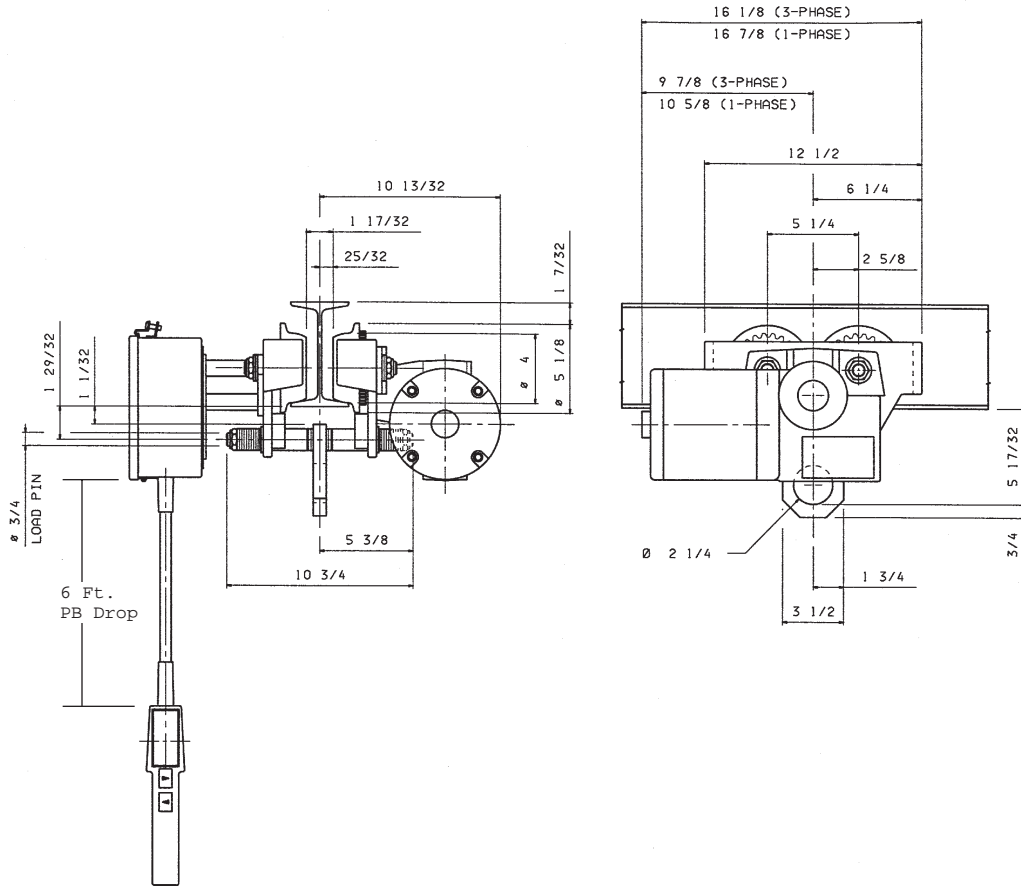

MT 3 Ton Motorized Trolley

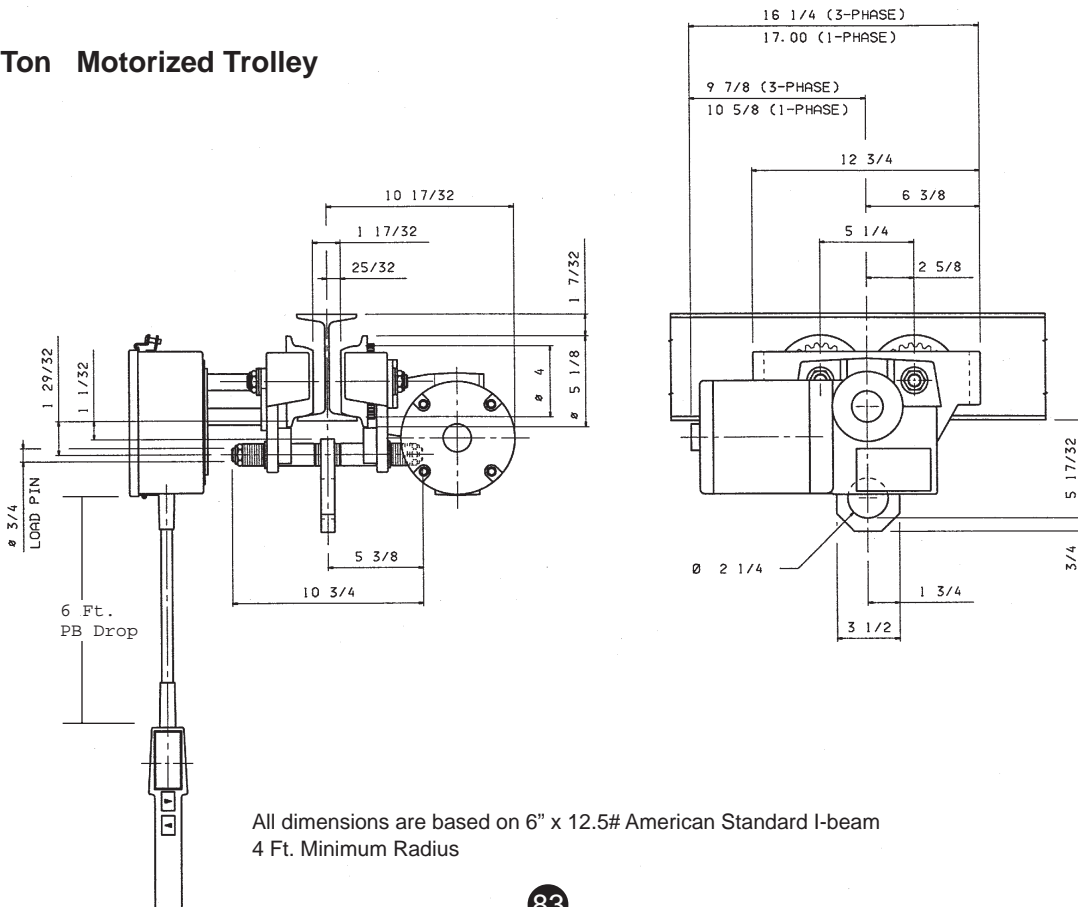

All dimensions are based on 6" x 12.5# American Standard I-beam
4 Ft. Minimum Radius

MT 4 & 5 Ton Motorized Trolleys

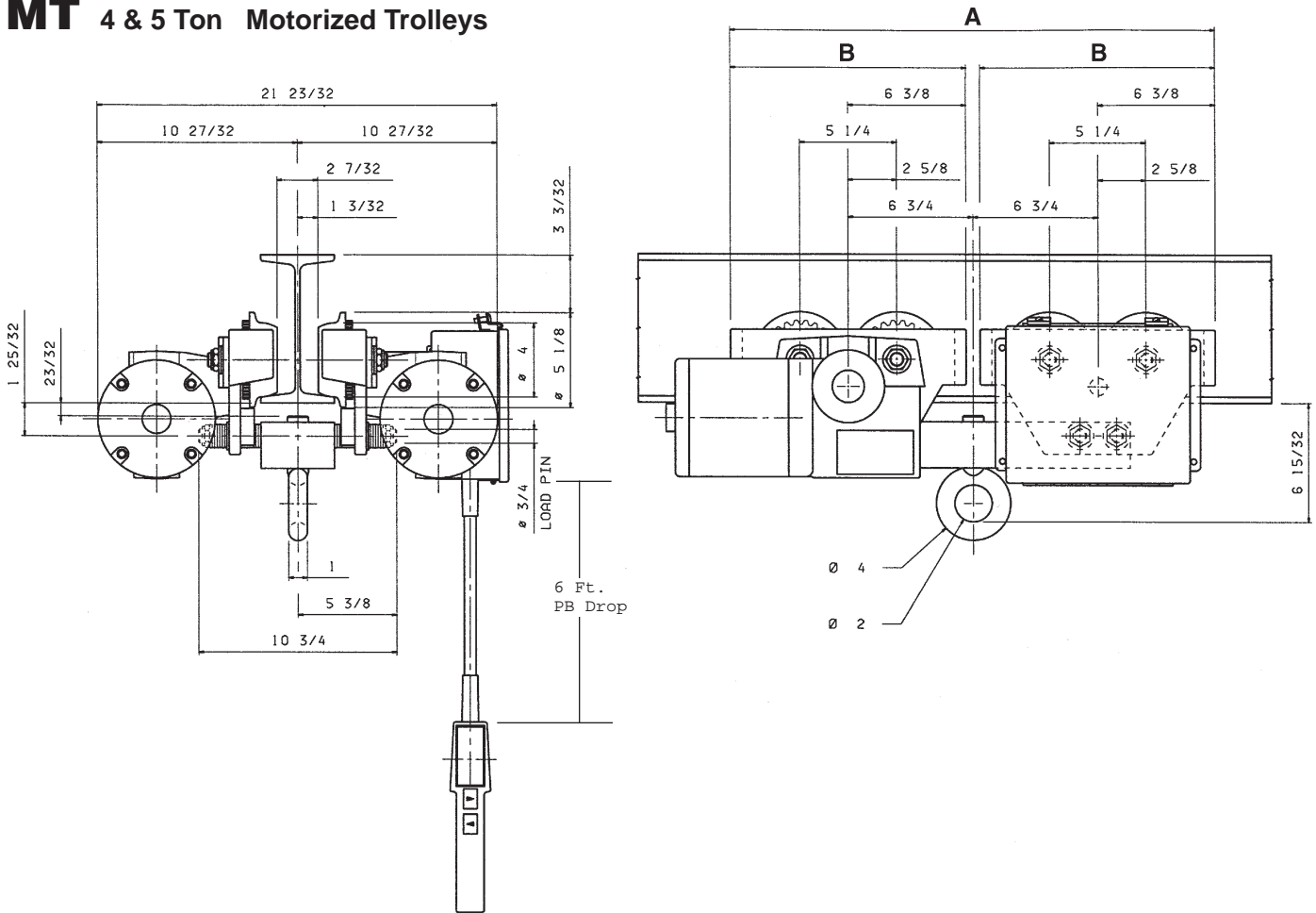

Specifications and Dimensions

Rated Load (Lbs.)	Beam Height (In.)	Flange Width (In.)	Weight (Lbs.)	Model Number*	A	B
8000	8 - 18	4.00 - 6.00	220	MT-80035	26	12 ¹ / ₂
8000	8 - 18	4.00 - 6.00	220	MT-80075	26	12 ¹ / ₂
10000	8 - 18	4.00 - 6.00	225	MT-100035	26 ¹ / ₄	12 ³ / ₄
10000	8 - 18	4.00 - 6.00	225	MT-100075	26 ¹ / ₄	12 ³ / ₄

All dimensions are based on 8" @ 18.4# American Standard I-beam.

All dimensions are in inches unless otherwise indicated.

"STRAIGHT TRACK ONLY"

Articulating models for 4-Ft. minimum radius curved track available, consult factory.

NOTE: For wide flange and patented track applications, consult factory.

Authorized Sales & Service
J. HERBERT CORPORATION
Call 1-800-255-0588
407-846-0588 Fax: 846-1066
info@jherbertcorp.com

Visit us online:
www.jherbertcorp.com