

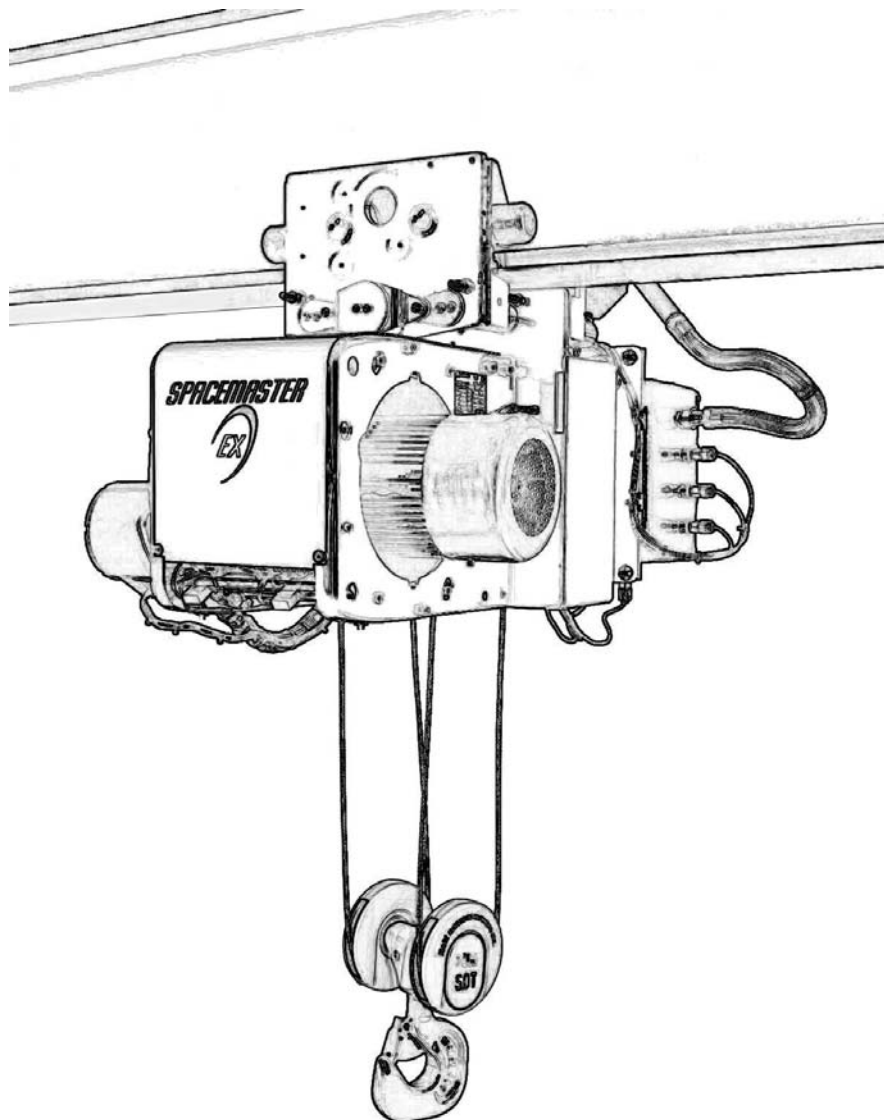

R&M Materials Handling, Inc
Springfield, Ohio USA
☎: 800 955-9967
www.rmhoist.com

Spacemaster® EX Electric Wire Rope Hoist
Technical Guide
January 2008

Spacemaster® EX Electric Wire Rope Hoist for Hazardous Locations



Technical Guide

Authorized Sales & Service

J. HERBERT CORPORATION

Call 1-800-255-0588

407-846-0588 Fax: 846-1066

info@jherbertcorp.com

Visit us online:

www.jherbertcorp.com



Table of Contents

1	Hoist Model Code Description	4
2	Hoist Technical Characteristics - Class I, Division 2	5
2.1	Height of Lift and Drum Code	5
2.2	Reeving.....	5
2.3	Hoist Speeds.....	5
2.4	Suspension Type Code.....	5
2.5	Rope Type Code.....	5
2.6	Hoist Duty Rating	5
2.7	Hoist Characteristic Table – US units	6
2.8	Hoist Characteristic Table – Metric units	11
3	EX Specification	16
4	EX Hoist Options	17
4.1	Stainless Steel Wire Rope – RR08	17
4.2	One-step Trolley Travel Limit Switch	17
4.3	Two-step Trolley Travel Limit Switch	17
4.4	Bronze Trolley Wheels.....	17
4.5	Bronze Coated Hook.....	17
4.6	Bronze Safety Lug	17
4.7	Horn	17
5	Hoist Limit Switches	18
5.1	Overtravel Protection	18
5.2	Overload Limiting Device	18
6	Hoisting Motors	19
6.1	Motor Data, Two-speed, 60 Hz - Class I, Division 2	19
6.2	Motor Currents, Two-speed, 60 Hz - Class I, Division 2	20
6.3	Motor Features - Class I, Division 2.....	20
7	Traveling Motors	21
7.1	Motor Data, MF06 Two-speed - Class I, Division 2	21
7.2	Motor Data, MF07 Two-speed - Class I, Division 2	22
8	Trolley Speed Tables	23
8.1	Class I, Division 2	23
8.1.1	Low Headroom, Contactor Control.....	23
8.1.2	Normal Headroom, Contactor Control.....	23
8.1.3	Double Girder, Contactor Control.....	23
9	Surface Treatment.....	24
9.1	Standard Painting System	24
9.2	Color Codes	25
10	Wire Rope Data.....	26



11	Materials	27
12	Load Block	29
12.1	Load Block Dimensions – U.S. units	29
12.2	Load Block Dimensions – Metric units.....	30
12.3	RSN and HBC Hook Dimensions – U.S. Units	31
12.4	RSN and HBC Hook Dimensions – Metric Units	32
13	Drum and Rope Sheave	33
13.1	Bottom Block Sheave Dimensions.....	33
13.2	Drum and Frame Sheave Dimensions.....	33



1 Hoist Model Code Description

SX Basic hoist type												
4		Frame size 4,5,6										
EX			Hazardous Location									
D2				Gas Group and Category D2 = Class I, Group C&D, Division 2 Temperature Class T3								
041					Rope reeving 021, 041, 061, 081 022, 042, 062, 082							
0050						Capacity 0050 = 50 x 100 kg = 5000 kg 0050 = 50 x 0.1 = 5 tons						
P							Hoisting motor control type P = Two-speed motor					
SX	4	EX	D2	041	0050	P	3	5	F	C	L0	N
Hoisting motor frame size		Power 60 Hz (hp)										
Power (kW)												
50Hz		60Hz										
2= 3.6	2= 4.3	2 = 5.8										
3= 4.5	3= 5.4	3 = 7.2										
4= 7.5	4= 9	4 = 12										
5= 9.0	5= 11	5 = 14.8										
6= 15.0	6= 18	6 = 24.1										
ISO Group (conventional metric capacities)				ASME (conventional U.S. capacities)								
3 = M3	5 = M5	4 = H3							5 = H4	5		
4 = M4	6 = M6	6 = H4+										
Hoisting gear (Speeds m/min and 4 ropes)						Hoisting gear (Speeds fpm and 4 ropes)						
Code	50 Hz	60Hz				Code						
E	4	4.8				E	16					
F	5 Standard	6				F	20 Standard					
G	6.3	7.56				G	25					
H	8	9.6				H	32					
J	10	12				J	50					
Hoist drum length (mm)						Hoist drum length (in.)						
A	310	H		1250		A	12.2		H		49.2	
B	340	J		1600		B	13.4		J		67	
C	440	K		1900		C	17.3		K		74.8	
D	540	L		2250		D	21.3		L		88.6	
E	660	M		2500		E	26		M		98.4	
F	810	N		2800		F	31.9		N		110.2	
G	1000											
Suspension type												
L0		Low headroom										
N0		Normal headroom										
D0		Double girder trolley (medium = standard)										
DH		Double girder trolley high model										
DL		Double girder trolley low model										
F0		Fixed hoist										
											L0	
Special properties												
N		Standard hoist without any options										
F		Options selected from option list										
S		Special hoist										
												N



2 Hoist Technical Characteristics - Class I, Division 2

The technical characteristics for Class I, Group C&D, Division 2 hoists are summarized in the following tables. The information in the first table is in U.S. units and the information in the second table is in metric units. The information in the tables include:

- Reeving type
- Availability of standard suspension types for each model
- Hoist duty rating
- Height of lift and corresponding drum length code
- Hoist speeds including alternate speeds
- Rope type code for each model

2.1 Height of Lift and Drum Code

The height of lift along with the corresponding drum length code is listed for each basic model. The drum code is included in the hoist model code.

2.2 Reeving

See Hoist Model Code Description for explanation of the reeving code.

2.3 Hoist Speeds

The hoist speeds for Class I, Group C&D, Division 2 hoists, along with the corresponding gear code and motor type, are listed in the technical characteristics tables. The gear code and motor type are included in the hoist model code. (Note: VFD controls are not available for these EX hoists.)

2.4 Suspension Type Code

Some of the suspension codes used in the Hoist Characteristics table may vary from those used in the price book. Suspension types that are available for each hoist model are marked with a code. Special suspensions are not included here.

Suspension Code (in Table)	Description
L	Low headroom trolley
DH	Double girder trolley–high: Height of trolley above the rail is higher than the standard trolley - to get better headroom below the rail.
DM	Double girder trolley–standard (medium connection)
DW	Double girder trolley–low: Height of trolley above the rail is lower than the standard trolley – to get better overhead clearance but it increases headroom.
N	Normal headroom trolley
F	Foot mount

2.5 Rope Type Code

The rope type code is listed for each height of lift. The characteristics of the wire rope can be found in the Wire Rope section. The double-reeved hoists use two separate ropes – a right-hand lay and a left-hand lay.

2.6 Hoist Duty Rating

ASME hoist duty rating (H3, H4, etc.) applies to hoists marked with conventional U.S. capacities (for example 1 ton = 2000 lbs = 907 kg) and does not apply to hoists marked with conventional metric capacities (for example 1 metric ton = 1,000 kg = 2,200 lbs).



2.7 Hoist Characteristic Table – US units

Capacity (TON) 1t=2000 lb	Hoist	Reeving	Trolley				Duty	Drum			Rope (*) Drum		Contactor control					
			D	D	D		ASME	Code	HOL (ft-in)	Load (lb)	Type	Gear		Motor	Speed (fpm)	(tm/ min)		
			L	H	M	N						F	V				Type	Ratio
1 1/2	SX4	021	L	H	M	N	F	H4+	B	39'-4"	1500	D	F	160.3	P 2	40/6.7	19.2	
			C	59'	F													
			D	78'-8"	F													
			H	M	N	F				E	98'-5"	F						
2	SX4	021	L	H	M	N	F	H4+	B	39'-4"	2000	D	F	160.3	P 3	40/6.7	24	
			C	59'	F													
			D	78'-8"	F													
			H	M	N	F				E	98'-5"	F						
2 1/2	SX4	021	L	H	M	N	F	H4	B	39'-4"	2500	D	F	160.3	P 3	40/6.7	30	
			C	59'	F													
			D	78'-8"	F													
			H	M	N	F				E	98'-5"	F						
3	SX4	041	L	H	M	N	F	H4+	B	19'-8"	1500	D	F	160.3	P 2	20/3.1	19.2	
			C	29'-6"														
			D	39'-4"														
			H	M	N	F				E	49'-2"							
4	SX4	041	L	H	M	N	F	H4+	B	19'-8"	2000	D	F	160.3	P 3	20/3.1	24	
			C	29'-6"														
			D	39'-4"														
			H	M	N	F				E	49'-2"							
5	SX4	041	L	H	M	N	F	H4	B	19'-8"	2500	D	F	160.3	P 3	20/3.1	30	
			C	29'-6"														
			D	39'-4"														
			H	M	N	F				E	49'-2"							
6	SX4	061	H	M	N	F	H4+	C	19'-8"	2000	C	F	160.3	P 3	12.5/1.9	24		
			D	26'-2"														
			E	32'-9"														
7 1/2	SX4	061	H	M	N	F	H4	C	19'-8"	2500	C	F	160.3	P 3	12.5/1.9	30		
			D	26'-2"														
			E	32'-9"														
7 1/2	SX4	081	H	M	N	F	H4	C	14'-9"	1875	C	F	160.3	P 3	10/1.5	24		
			D	19'-8"														
			E	24'-7"														
10	SX4	081	H	M	N	F	H3	C	14'-9"	2500	C	F	160.3	P 3	10/1.5	30		
			D	19'-8"														
			E	24'-7"														
4	SX5	021	L	H	M	W	N	F	H4+	D	59'	4000	G	F	185.3	P 5	40/6.7	48
			E	78'-8"	J													
			F	104'-11"	J													
			H	M	W	N	F				G	131'-2"	J					
5	SX5	021	L	H	M	W	N	F	H4	D	59'	5000	G	F	185.3	P 5	40/6.7	60
			E	78'-8"	J													
			F	104'-11"	J													
			H	M	W	N	F				G	131'-2"	J					
6	SX5	041	L	H	M	W	N	F	H4+	D	29'-6"	3000	G	F	185.3	P 5	20/3.1	38
			E	39'-4"														
			F	52'-5"														
			H	M	W	N	F				G	65'-7"						



Capacity (TON) 1t=2000 lb	Hoist	Reeving	Trolley				Duty	Drum			Rope *) Drum		Contactor control				
			D D D L H M W N F V					ASME	Code	HOL (ft-in)	Load (lb)	Type	Gear		Motor	Speed (fpm)	(tm/ min)
			Type	Ratio													
7 1/2	SX5	041	L H M W N F	H4+	D	29'-6"	3750	G	F	185.3	P 5	20/3.1	48				
			H						113.8	P 6	30/4.9	76					
10	SX5	041	L H M W N F	H4	D	29'-6"	5000	G	F	185.3	P 5	20/3.1	60				
			H						113.8	P 6	30/4.9	96					
12	SX5	061	H M W N F	H4+	D	19'-8"	4000	H	F	185.3	P 5	12.5/1.9	48				
			H						113.8	P 6	20/3.1	76					
15	SX5	061	H M W N F	H4	D	19'-8"	5000	H	F	185.3	P 5	12.5/1.9	60				
			H						113.8	P 6	20/3.1	96					
15	SX5	081	H M W N F	H4	D	14'-9"	3750	H	F	185.3	P 5	10/1.5	48				
			H						113.8	P 6	16/2.4	76					
20	SX5	081	H M W N F	H3	D	14'-9"	5000	H	F	185.3	P 5	10/1.5	60				
			H						113.8	P 6	16/2.4	96					

4	SX5	022	H M W F	H4+	D	27'-10"	2000	D + Dr	F	185.3	P 5	40/6.7	48	
					E	42'-7"			*4000	H	113.8	P 6	60/9.8	76
					F	59'								
					G	82'								
					H	109'-10"								
					J	150'-11"								
5	SX5	022	H M W F	H4	D	27'-10"	2500	D + Dr	F	185.3	P 5	40/6.7	60	
					E	42'-7"			*5000	H	113.8	P 6	60/9.8	96
					F	59'								
					G	82'								
					H	109'-10"								
					J	150'-11"								
6	SX5	042	H M W F	H4+	D	13'-1"	1500	D + Dr	F	185.3	P 5	20/3.1	38	
					E	21'-3"			*3000	H	113.8	P 6	30/4.9	60
					F	29'-6"								
					G	41'								
					H	54'-1"								
					J	75'-5"								
7 1/2	SX5	042	H M W F	H4+	D	13'-1"	1875	D + Dr	F	185.3	P 5	20/3.1	48	
					E	21'-3"			*3750	H	113.8	P 6	30/4.9	76
					F	29'-6"								
					G	41'								
					H	54'-1"								
					J	75'-5"								



Capacity (TON) 1t=2000 lb	Hoist	Reeving	Trolley				Duty	Drum		Rope *) Drum		Contactor control											
			D	D	D			ASME	Code	HOL (ft-in)	Load (lb)	Type	Gear		Motor	Speed (fpm)	(tm/ min)						
			L	H	M	W	N	F	V	Type	Ratio												
10	SX5	042	H	M	W	F	H4	D	13'-1"	2500	D	F	185.3	P	5	20/3.1	60						
								E	21'-3"			*5000	+					H	113.8	P	6	30/4.9	96
								F	29'-6"				Dr										
								G	41'														
								H	54'-1"														
J	75'-5"																						
12	SX5	062	H	M	W	F	H4+	E	13'-1"	2000	E	F	185.3	P	5	12.5/1.9	48						
								F	19'-8"			*4000	+					H	113.8	P	6	20/3.1	76
								G	26'-2"				Er										
								H	36'-1"														
								J	49'-2"														
15	SX5	062	H	M	W	F	H4	E	13'-1"	2500	E	F	185.3	P	5	12.5/1.9	60						
								F	19'-8"			*5000	+					H	113.8	P	6	20/3.1	96
								G	26'-2"				Er										
								H	36'-1"														
								J	49'-2"														
15	SX5	082	H	M	W	F	H4	F	14'-9"	1875	E	F	185.3	P	5	10/1.5	48						
								G	19'-8"			*3750	+					H	113.8	P	6	16/2.4	76
								H	26'-2"				Er										
								J	37'-8"														
20	SX5	082	H	M	W	F	H3	F	14'-9"	2500	E	F	185.3	P	5	10/1.5	60						
								G	19'-8"			*5000	+					H	113.8	P	6	16/2.4	96
								H	26'-2"				Er										
								J	37'-8"														

6	SX6	021	M	N	F	H4+	C	50'-10"	6000	K	E	344.9	P	6	30/4.9	60					
							D	68'-10"			M	F					269.1	P	6	40/6.7	76
							E	91'-10"													
							F	118'-1"													
							G	154'-2"													
							H	200'-1"													
							J	264'-1"													
7 1/2	SX6	021	M	N	F	H4	C	50'-10"	7500	K	E	344.9	P	6	30/4.9	76					
							D	68'-10"			M	F					269.1	P	6	40/6.7	96
							E	91'-10"													
							F	118'-1"													
							G	154'-2"													
							H	200'-1"													
							J	264'-1"													
10	SX6	021	M	N	F	H3	C	50'-10"	10000	K	E	344.9	P	6	30/4.9	96					
							D	68'-10"			M										
							E	91'-10"													
							F	118'-1"													
							G	154'-2"													
							H	200'-1"													
							J	264'-1"													
K	318'-2"																				



Capacity (TON) 1t=2000 lb	Hoist	Reeving	Trolley				Duty	Drum		Rope *) Drum		Contactor control							
			D	D	D			ASME	Code	HOL (ft-in)	Load (lb)	Type	Gear		Motor P 6	Speed (fpm)	(tm/ min)		
			L	H	M	W	N	F	V	Type	Ratio								
12 1/2	SX6	041	M	N	F	H4+	C	24'-6"	6250	K	E	344.9	P 6	16/2.4	60				
							D	34'-5"			F					269.1	P 6	20/3.1	76
							E	45'-11"											
							F	59'											
							G	77'-1"											
							H	100'											
							J	131'-2"											
K	159'-1"																		
15	SX6	041	M	N	F	H4	C	24'-6"	7500	K	E	344.9	P 6	16/2.4	76				
							D	34'-5"			F					269.1	P 6	20/3.1	96
							E	45'-11"											
							F	59'											
							G	77'-1"											
							H	100'											
							J	131'-2"											
K	159'-1"																		
20	SX6	041	M	N	F	H3	C	24'-6"	10000	K	E	344.9	P 6	16/2.4	96				
							D	34'-5"											
							E	45'-11"											
							F	59'											
							G	77'-1"											
							H	100'											
							J	131'-2"											
K	159'-1"																		
20	SX6	061	M	N	F	H4+	C	16'-4"	6667	L	E	344.9	P 6	10/1.5	60				
							D	22'-11"			F					269.1	P 6	12.5/1.9	76
							E	29'-6"											
							F	39'-4"											
							G	50'-10"											
							H	65'-7"											
							J	86'-11"											
K	105'																		

6	SX6	022	M	N	F	H4+	E	54'-2"	3000	G + Gr	E	344.9	P 6	30/4.9	60					
							F	72'-2"			*6000					F	269.1	P 6	40/6.7	76
							G	96'-9"												
							H	127'-11"												
							J	170'-7"												
							K	208'-4"												
							L	252'-7"												
7 1/2	SX6	022	M	N	F	H4	E	54'-2"	3750	G + Gr	E	344.9	P 6	30/4.9	76					
							F	72'-2"			*7500					F	269.1	P 6	40/6.7	96
							G	96'-9"												
							H	127'-11"												
							J	170'-7"												
							K	208'-4"												
							L	252'-7"												
M	283'-10"																			
N	321'-6"																			



Capacity (TON) 1t=2000 lb	Hoist	Reeving	Trolley			Duty	Drum		Rope *) Drum		Contactor control							
			D	D	D	ASME	Code	HOL (ft-in)	Load (lb)	Type	Gear		Motor P 6	Speed (fpm)	(tm/ min)			
			L	H	M						W	N				F	V	Type
10	SX6	022	M	N	F	H3	E	54'-2"	5000	G	E	344.9	P 6	30/4.9	96			
							F	72'-2"								*10000	+	
							G	96'-9"										Gr
							H	127'-11"										
							J	170'-7"										
							K	208'-4"										
							L	252'-7"										
M	283'-10"																	
N	321'-6"																	
12 1/2	SX6	042	M	N	F	H4+	E	26'-3"	3200	G	E	344.9	P 6	16/2.4	60			
							F	36'-1"								*6400	+	
							G	47'-7"										Gr
							H	64'-0"										
							J	85'-4"										
							K	103'-4"										
							L	126'-4"										
M	141'-1"																	
N	160'-9"																	
15	SX6	042	M	N	F	H4	E	26'-3"	3750	G	E	344.9	P 6	16/2.4	76			
							F	36'-1"								*7500	+	
							G	47'-7"										Gr
							H	64'-0"										
							J	85'-4"										
							K	103'-4"										
							L	126'-4"										
M	141'-1"																	
N	160'-9"																	
20	SX6	042	M	N	F	H3	E	26'-3"	5000	G	E	344.9	P 6	16/2.4	96			
							F	36'-1"								*10000	+	
							G	47'-7"										Gr
							H	64'-0"										
							J	85'-4"										
							K	103'-4"										
							L	126'-4"										
M	141'-1"																	
N	160'-9"																	
20	SX6	062	M	N	F	H4+	E	18'-1"	3340	H	E	344.9	P 6	10/1.5	60			
							F	23'-0"								*6680	+	
							G	31'-2"										Hr
							H	42'-8"										
							J	55'-9"										
							K	68'-11"										
							L	83'-8"										
M	93'-6"																	
N	106'-8"																	

* Drum load



2.8 Hoist Characteristic Table – Metric units

Load Kg	Hoist	Reeving	Trolley		Duty		Drum		Rope *) Drum		Contactor control								
			D D D		FEM	ISO	Code	HOL	Load	Ty	Gear		Motor	Speed	(tm/				
			L	H	M	W	N	F	V		(m)	(kg)	pe	Type	Ratio	(m/min)	min)		
1600	SX4	021	L	H	M	N	F		3m	M6	B	12	800	D	F	160.3	P 2	12/2	19.2
									C	18	F								
									D	24	F								
2000	SX4	021	L	H	M	N	F		3m	M6	B	12	1000	D	F	160.3	P 3	12/2	24
									C	18	F								
									D	24	F								
2500	SX4	021	L	H	M	N	F		2m	M5	B	12	1250	D	F	160.3	P 3	12/2	30
									C	18	F								
									D	24	F								
3200	SX4	041	L	H	M	N	F		3m	M6	B	6	800	D	F	160.3	P 2	6/1	19.2
									C	9									
									D	12									
4000	SX4	041	L	H	M	N	F		3m	M6	B	6	1000	D	F	160.3	P 3	6/1	24
									C	9									
									D	12									
5000	SX4	041	L	H	M	N	F		2m	M5	B	6	1250	D	F	160.3	P 3	6/1	30
									C	9									
									D	12									
6000	SX4	061	H	M	N	F			3m	M6	C	6	1000	C	F	160.3	P 3	3.8/0.6	24
									D	8									
									E	10									
7500	SX4	061	H	M	N	F			2m	M5	C	6	1250	C	F	160.3	P 3	3.8/0.6	30
									D	8									
									E	10									
8000	SX4	081	H	M	N	F			2m	M5	C	4.5	1250	C	F	160.3	P 3	3/0.5	24
									D	6									
									E	7.5									
10000	SX4	081	H	M	N	F			1Am	M4	C	4.5	1250	C	F	160.3	P 3	3/0.5	30
									D	6									
									E	7.5									

4000	SX5	021	L	H	M	W	N	F	3m	M6	D	18	2000	G	F	185.3	P 5	12/2	48				
											E	24			H					113.8	P 6	19/3.2	76
											F	32			J								
5000	SX5	021	L	H	M	W	N	F	2m	M5	D	18	2500	G	F	185.3	P 5	12/2	60				
											E	24			H					113.8	P 6	19/3.2	96
											F	32			J								
6300	SX5	041	L	H	M	W	N	F	3m	M6	D	9	1600	G	F	185.3	P 5	6/1	38				
											E	12			H					113.8	P 6	9.5/1.6	60
											F	16											
			H	M	W	N	F				G	20											



Load Kg	Hoist	Reeving	Trolley		Duty		Drum		Rope *) Drum		Contactor control								
			D D D		FEM	ISO	Code	HOL	Load	Type	Gear		Motor	Speed	(tm/ min)				
			L	H	M	W	N	F	V	(m)	(kg)		Type	Ratio	(m/min)				
8000	SX5	041	L	H	M	W	N	F	3m	M6	D	9	2000	G	F	185.3	P 5	6/1	48
									E	12	H	113.8			P 6	9.5/1.6	76		
									F	16									
			H	M	W	N	F			G	20								
10000	SX5	041	L	H	M	W	N	F	2m	M5	D	9	2500	G	F	185.3	P 5	6/1	60
									E	12	H	113.8			P 6	9.5/1.6	96		
									F	16									
			H	M	W	N	F			G	20								
12000	SX5	061	H	M	W	N	F	3m	M6	D	6	2000	H	F	185.3	P 5	3.8/0.6	48	
									E	8	H			113.8	P 6	6/1	76		
									F	10									
									G	13									
15000	SX5	061	H	M	W	N	F	2m	M5	D	6	2500	H	F	185.3	P 5	3.8/0.6	60	
									E	8	H			113.8	P 6	6/1	96		
									F	10									
									G	13									
16000	SX5	081	H	M	W	N	F	2m	M5	D	4.5	2000	H	F	185.3	P 5	3/0.5	48	
									E	6	H			113.8	P 6	4.8/0.8	76		
									F	8									
									G	10									
20000	SX5	081	H	M	W	N	F	1Am	M4	D	4.5	2500	H	F	185.3	P 5	3/0.5	60	
									E	6	H			113.8	P 6	4.8/0.8	96		
									F	8									
									G	10									

4000	SX5	022	H	M	W	F	3m	M6	D	8.5	1000 *2000	D + Dr	F	185.3	P 5	12/2	48	
									E	13			H	113.8	P 6	19/3.2	76	
									F	18								
									G	25								
									H	33.5								
									J	46								
5000	SX5	022	H	M	W	F	2m	M5	D	8.5	1250 *2500	D + Dr	F	185.3	P 5	12/2	60	
									E	13			H	113.8	P 6	19/3.2	96	
									F	18								
									G	25								
									H	33.5								
									J	46								
6300	SX5	042	H	M	W	F	3m	M6	D	4	800 *1600	D + Dr	F	185.3	P 5	6/1	38	
									E	6.5			H	113.8	P 6	9.5/1.6	60	
									F	9								
									G	12.5								
									H	16.5								
									J	23								
8000	SX5	042	H	M	W	F	3m	M6	D	4	1000 *2000	D + Dr	F	185.3	P 5	6/1	48	
									E	6.5			H	113.8	P 6	9.5/1.6	76	
									F	9								
									G	12.5								
									H	16.5								
									J	23								



Load Kg	Hoist	Reeving	Trolley			Duty		Drum		Rope *) Drum		Contactor control				
			D D D	FEM	ISO	Code	HOL	Load	Typ	Gear		Motor	Speed (m/min)	(tm/ min)		
			L H M W N F V				(m)	(kg)	e	Type	Ratio					
10000	SX5	042	H M W F	2m	M5	D E F G H J	4 6.5 9 12.5 16.5 23	1250 *2500	D + Dr	F H	185.3 113.8	P 5 P 6	6/1 9.5/1.6	60 96		
12000	SX5	062	H M W F	3m	M6	E F G H J	4 6 8 11 15	1000 *2000	E + Er	F H	185.3 113.8	P 5 P 6	3.8/0.6 6/1	48 76		
15000	SX5	062	H M W F	2m	M5	E F G H J	4 6 8 11 15	1250 *2500	E + Er	F H	185.3 113.8	P 5 P 6	3.8/0.6 6/1	60 96		
16000	SX5	082	H M W F	2m	M5	F G H J	4.5 6 8 11.5	1000 *2000	E + Er	F H	185.3 113.8	P 5 P 6	3/0.5 4.8/0.8	48 76		
20000	SX5	082	H M W F	1Am	M4	F G H J	4.5 6 8 11.5	1250 *2500	E + Er	F H	185.3 113.8	P 5 P 6	3/0.5 4.8/0.8	60 96		

6300	SX6	021	M N F	3m	M6	C	15.5	3150	K	E	344.9	P 6	9.5/1.6	60					
						D	21								F	269.1	P 6	12/2	76
						E	28												
						F	36												
						G	47												
						H	61												
						J	80.5												
K	97																		
8000	SX6	021	M N F	2m	M5	C	15.5	4000	K	E	344.9	P 6	9.5/1.6	76					
						D	21								F	269.1	P 6	12/2	96
						E	28												
						F	36												
						G	47												
						H	61												
						J	80.5												
K	97																		
10000	SX6	021	M N F	1Am	M4	C	15.5	5000	K	E	344.9	P 6	9.5/1.6	96					
						D	21								F	269.1	P 6	12/2	96
						E	28												
						F	36												
						G	47												
						H	61												
						J	80.5												
K	97																		



Load Kg	Hoist	Reeving	Trolley					Duty		Drum		Rope *) Drum		Contactor control									
			D	D	D	L	H	M	W	N	F	V	FEM	ISO	Code	HOL (m)	Load (kg)	Ty pe	Gear		Motor P 6	Speed (m/min)	(tm/ min)
			Type	Ratio	Type	Ratio	Type	Ratio	Type	Ratio	Type	Ratio											
12500	SX6	041	M	N	F	3m	M6	C	7.5	3125	K	E	344.9	P 6	4.8/0.8	60							
								D	10.5			F	269.1				P 6	6/1	76				
								E	14														
								F	18														
								G	23.5														
								H	30.5														
								J	40														
K	48.5																						
16000	SX6	041	M	N	F	2m	M5	C	7.5	4000	K	E	344.9	P 6	4.8/0.8	76							
								D	10.5			F	269.1				P 6	6/1	96				
								E	14														
								F	18														
								G	23.5														
								H	30.5														
								J	40														
K	48.5																						
20000	SX6	041	M	N	F	1Am	M4	C	7.5	5000	K	E	344.9	P 6	4.8/0.8	96							
								D	10.5														
								E	14														
								F	18														
								G	23.5														
								H	30.5														
								J	40														
K	48.5																						
20000	SX6	061	M	N	F	3m	M6	C	5	3340	L	E	344.9	P 6	3/0.5	60							
								D	7			F	269.1				P 6	3.8/0.6	76				
								E	9														
								F	12														
								G	15.5														
								H	20														
								J	26.5														
K	32																						

6300	SX6	022	M	N	F	3m	M6	E	16.5	1575	G + Gr	E	344.9	P 6	9.5/1.6	60			
								F	22			F	269.1				P 6	12/2	76
								G	29.5										
								H	39										
								J	52										
								K	63.5										
								L	77										
M	86.5																		
N	98																		
8000	SX6	022	M	N	F	2m	M5	E	16.5	2000	G + Gr	E	344.9	P 6	9.5/1.6	76			
								F	22			F	269.1				P 6	12/2	96
								G	29.5										
								H	39										
								J	52										
								K	63.5										
								L	77										
M	86.5																		
N	98																		



Load Kg	Hoist	Reeving	Trolley			Duty		Drum		Rope *) Drum		Contactor control								
			D	D	D	FEM	ISO	Code	HOL (m)	Load (kg)	Type	Gear		Motor	Speed (m/min)	(tm/min)				
			L	H	M	W	N	F	V					Type	Ratio					
10000	SX6	022	M	N	F	1Am	M4	E	16.5	2500	G	E	344.9	P	6	9.5/1.6	96			
								F	22									*5000	+	Gr
								G	29.5											
								H	39											
								J	52											
								K	63.5											
								L	77											
								M	86.5											
								N	98											
12500	SX6	042	M	N	F	3m	M6	E	8	1600	G	E	344.9	P	6	4.8/0.8	60			
								F	11									*3200	+	Gr
								G	14.5											
								H	19.5											
								J	26											
								K	31.5											
								L	38.5											
								M	43											
								N	49											
16000	SX6	042	M	N	F	2m	M5	E	8	2000	G	E	344.9	P	6	4.8/0.8	76			
								F	11									*4000	+	Gr
								G	14.5											
								H	19.5											
								J	26											
								K	31.5											
								L	38.5											
								M	43											
								N	49											
20000	SX6	042	M	N	F	1Am	M4	E	8	2500	G	E	344.9	P	6	4.8/0.8	96			
								F	11									*5000	+	Gr
								G	14.5											
								H	19.5											
								J	26											
								K	31.5											
								L	38.5											
								M	43											
								N	49											
20000	SX6	062	M	N	F	3m	M6	E	5.5	1670	H	E	344.9	P	6	3/0.5	60			
								F	7									*3340	+	Hr
								G	9.5											
								H	13											
								J	17											
								K	21											
								L	25.5											
								M	28.5											
								N	32.5											

* Drum load



3 EX Specification

Class I, Group C&D, Division 2 Temperature Class T3

Equipment	Type	Protection Rating	IP degree / Nema Type
Hoisting motor	P2, P3, P5, P6		IP55
Traveling motor	MF06LA, MF07X		IP55
Hoisting limit switch	XCW-A1155	EEx d IIC T6	IP67
Overload device	XCW-A1105	EEx d IIC T6	IP67
Control enclosure	XCE..... N4	Class I, Groups C&D Class II, Groups E, F&G Class III	NEMA 4, 7, 9
Pendant push button box	XAW-P049, XAW-P069, XAW-P089	EEx de IIC T6	IP54 – enclosure IP65 - contacts
Horn (110 dB @ 3 ft) (100 dB @ 10 ft)	350WBX	Class I, Division 2, Groups A, B, C, and D Class II, Division 2, Groups Fand G Class III	Type 4X enclosure
Flashing light	225XST	Class I, Division 2, Groups A, B, C, and D Class II, Division 2, Groups Fand G Class III	Type 4X, IP66 enclosure
Trolley travel limit switch	XCKWMR54D1H29	EEX ed IIC T6	IP66



4 EX Hoist Options

4.1 Stainless Steel Wire Rope – RR08

When stainless wire rope is needed as an alternative to the standard wire rope, contact R&M for assistance in evaluating and selecting the hoist. Note: Stainless steel wire rope has a lower breaking strength than the standard wire rope.

4.2 One-step Trolley Travel Limit Switch

The one-step trolley travel limit switch is a stop limit and is designed to stop the trolley traveling when the switch is tripped. Or instead of the stop limit, the switch can be set up as a slow-down limit when specified at order entry.

4.3 Two-step Trolley Travel Limit Switch

The two-step trolley travel limit switch is a slow-down and stop limit and is designed so the trolley drive operates only in slow speed when the first step of the switch is tripped. When the second step of the switch is tripped, it stops the trolley traveling.

4.4 Bronze Trolley Wheels

A solid bronze trolley wheel that matches the profile of the standard wheel.

4.5 Bronze Coated Hook

A bronze coating is applied to the standard hook. The thickness of the bronze coating is of 60 µm.

4.6 Bronze Safety Lug

A solid bronze safety lug is available for trolleys to meet the mechanical spark resistant requirement.

4.7 Horn

The horn, suitable for for Class I, Division 2 application and outdoor service, has a sound level of 110 dB at 3 feet [1 m] or 100 dB at 10 feet [3 m].



5 Hoist Limit Switches

5.1 Overtravel Protection

The EX hoist is equipped with limit switches for overtravel protection in the upper and lower limits of lift travel. The limit switches can be adjusted. This limiting device operates in relation to the drum turns. A bronze wheel, which rides in the groove of the drum and moves linearly, activates the switches.

5.2 Overload Limiting Device

The EX hoist is equipped with overload limiting device to protect against damage from attempts to lift an over-capacity load. The overload device is electro-mechanical and is factory set to cut off at 110% of the capacity.



6 Hoisting Motors

6.1 Motor Data, Two-speed, 60 Hz - Class I, Division 2

Duty Group Fem/ISO	Motor data			P2		P3		P5		P6	
				MF10Z-106	600	MF10X-106	600	MF11X-106	600	MF13Z-106	600
		Synchronous speed	RPM	3600	600	3600	600	3600	600	3600	600
		Brake torque	Nm	21		42		54		100	
		Max el. br. torque	Nm		63		77		112		182
		El. br. torque	Nm		25		38		64		82
		Power fact. start		0.77	0.73	0.78	0.74	0.75	0.68	0.60	0.64
		Starting torque	Nm	24.6	21.7	34	28	63	51	102	82
		Weight	lb	67.46		77.16		130.07		189.59	
		Brake inertia	kgm ²	0.00017		0.00045		0.0007		0.0007	
		Inertia w/o brake	kgm ²	0.0049		0.0059		0.0116		0.036	
2m/M5	300 starts/h 40 % ED 30/3.5 min	Load	tm/min	24		30		60		96	
		Nominal power	hp	5.85	0.95	7.34	1.22	14.96	2.18	24.48	4.08
		Nominal torque	Nm	12.3	12.3	15.3	15.3	30	30	48	48
		Nominal speed	RPM	3400	500	3350	495	3250	440	3320	515
		Short time duty	min	60	15	30	15	30	10	30	15
		Power factor		0.89	0.61	0.93	0.60	0.91	0.57	0.88	0.59
		Efficiency		0.75	0.38	0.74	0.36	0.75	0.35	0.80	0.50
3m/M6	300 starts/h 50 % ED 30/4 min	Load	tm/min	19.2		24		48		76	
		Nominal power	hp	4.76	0.68	5.85	0.95	12.24	1.90	19.04	3.13
		Nominal torque	Nm	9.8	9.8	12.3	12.3	24	24	38	38
		Nominal speed	RPM	3450	520	3410	530	3320	470	3390	540
		Short time duty	min								
		Power factor		0.87	0.54	0.91	0.53	0.90	0.53	0.85	0.52
		Efficiency		0.75	0.36	0.75	0.34	0.77	0.35	0.82	0.48
	300 starts/h 60 % ED	Load	tm/min	15		19.2		38		60	
		Nominal power	hp	3.94	0.54	4.76	0.68	9.79	1.63	14.96	2.18
		Nominal torque	Nm	7.7	7.7	9.8	9.8	19.2	19.2	30	30
		Nominal speed	RPM	3490	540	3450	540	3395	500	3445	555
		Short time duty	min								
		Power factor		0.82	0.49	0.88	0.49	0.87	0.47	0.82	0.48
		Efficiency		0.74	0.31	0.75	0.31	0.77	0.34	0.82	0.46
	300 starts/h 60 % ED	Load	tm/min	12		15		30		48	
		Nominal power	hp	2.99	0.41	3.94	0.54	7.34	1.22	12.24	1.9
		Nominal torque	Nm	6.1	6.1	7.7	7.7	15.3	15.3	24	24
		Nominal speed	RPM	3520	550	3490	550	3450	525	3495	565
		Short time duty	min								
		Power factor		0.76	0.45	0.85	0.45	0.83	0.42	0.74	0.42
		Efficiency		0.71	0.28	0.73	0.28	0.77	0.31	0.82	0.39



6.2 Motor Currents, Two-speed, 60 Hz - Class I, Division 2

		Currents								
		Nominal voltage		220 V		380 V		460 V		575 V
Used in voltage range		208...230 V		360...400 V		440...480 V		575...600 V		
		tm/min	fast	slow	fast	slow	fast	slow	fast	slow
P2 MF10Z-106	Starting current (A)		90	15	52	8.8	43	7.3	34	5.8
	Nominal current (A)									
		24	17	8.4	10	4.8	8.3	4.0	6.6	3.2
		19.2	15.3	8.2	8.8	4.7	7.3	3.9	5.8	3.1
		15	12.5	8.2	7.3	4.7	6	3.9	4.8	3.1
		12	11.5	8.2	6.7	4.7	5.5	3.9	4.4	3.1
	No-load current (A)		7.9	8.6	4.6	5.0	3.8	4.1	3.0	3.3
P3 MF10X-106	Starting current (A)		102	18	59	10.2	49	8.4	39	6.7
	Nominal current (A)									
		30	22	11	13	6.5	10	5.4	8.2	4.3
		24	18	10.2	10.3	5.9	8.5	4.9	6.8	3.9
		19.2	15	10.2	8.7	5.9	7.2	4.9	5.8	3.9
		15	13	10.2	7.3	5.9	6	4.9	4.8	3.9
	No-load current (A)		8.4	11.3	4.8	6.5	4	5.4	3.2	4.3
P5 MF11X-106	Starting current (A)		167	31	97	18.2	80	15	64	12.0
	Nominal current (A)									
		60	42	21	24	12	20	10	16	8.0
		48	33	18	19	10.5	16	8.7	12.8	7.0
		38	28	18	16	10.3	13.5	8.5	10.8	6.8
		30	23	18	13	10.3	11	8.5	8.8	6.8
	No-load current (A)		14	20	8.1	11.5	6.7	9.5	5.4	7.6
P6 MF13Z-106	Starting current (A)		312	52	180	30	149	25	119	20
	Nominal current (A)									
		96	67	27	39	16	32	13	26	10
		76	54	27	31	15.7	26	13	21	10.4
		60	46	25	27	14.5	22	12	18	9.6
		48	36	25	21	14.5	17	12	13.6	9.6
	No-load current (A)		27	25	16	14.5	13	12	10.4	9.6

6.3 Motor Features - Class I, Division 2

- Two-speed with 6:1 speed ratio
- D.C. disc brake
- Class F insulation
- IP55 motor protection
- Thermal protection



7 Traveling Motors

7.1 Motor Data, MF06 Two-speed - Class I, Division 2

Duty type	Motor code	MF06LA104		MF06LA104		MF06LA104	
	Speed control	2-speed		2-speed		2-speed	
	Voltage	400 V		460 V		575 V	
	Frequency	50 Hz		60 Hz		60 Hz	
	Brake type	DC		DC		DC	
		fast	slow	fast	slow	fast	slow
	Synchronous speed RPM	3000	750	3600	900	3600	900
	Brake torque Nm	2	2	2	2	2	2
	Starting torque Nm	3.3	2.5	3.3	2.4	3.3	2.4
	Electric braking torque Nm		8/3.5		8/3.5		8/3.5
	Starting current A	5.0	1.4	5.3	1.5	4.24	1.2
	Maximum torque Nm	3.6	2.7	3.5	2.6	3.5	2.6
	Speed at max. torque RPM	1620	380	2220	530	2220	530
	80% of max. torque Nm	2.8	2.1	2.7	2.0	2.7	2.0
	Speed at 80% torque RPM	2100	530	2800	680	2800	680
	Current at 80% torque A	2.3	1.3	2.2	1.3	2.2	1.3
	Inertia kgm ²	0.0006	0.0006	0.0006	0.0006	0.0006	0.0006
	Inertia with flywheel kgm ²						
	Power factor, starting	0.92	0.93	0.91	0.92	0.91	0.92
	Weight with fan lb						
	Weight lb	17.2		17.2		17.2	
	No-load current A	1.1	1.2	1.1	1.2	0.88	0.96
	Iron losses W						
	Stator resistance at 20 °C Ω	50	175	50	175	50	175
S3-20%	Speed RPM	2760	660	3340	810	3340	810
	Power hp	0.61	0.14	0.75	0.16	0.75	0.16
	Current A	1.3	1.2	1.3	1.2	1.04	0.96
	Starting burden kgm ² /h	3		2.1		2.1	
	Power factor	0.83	0.67	0.82	0.80	0.82	0.80
	Efficiency	0.67	0.20	0.67	0.20	0.67	0.20
S3-40%	Speed RPM	2760	660	3340	810	3340	810
	Power hp	0.61	0.14	0.75	0.16	0.75	0.16
	Current A	1.3	1.2	1.3	1.2	1.04	0.96
	Starting burden kgm ² /h	2.5		1.9		1.9	
	Power factor	0.83	0.67	0.82	0.80	0.82	0.80
	Efficiency	0.67	0.20	0.67	0.20	0.67	0.20
S3-60%	Speed RPM						
	Power hp						
	Current A						
	Starting burden kgm ² /h						
	Power factor						
	Efficiency						
S3-100%	Speed RPM						
	Power hp						
	Current A						
	Starting burden kgm ² /h						
	Power factor						
	Efficiency						



7.2 Motor Data, MF07 Two-speed - Class I, Division 2

Duty type	Motor code	MF07X-104		MF07X-104		MF07X-104	
		fast	slow	fast	slow	fast	slow
	Speed control	2-speed		2-speed		2-speed	
	Voltage	400 V		460 V		575 V	
	Frequency	50 Hz		60 Hz		60 Hz	
	Brake type	DC		DC		DC	
		fast	slow	fast	slow	fast	slow
	Synchronous speed RPM	3000	750	3600	900	3600	900
	Brake torque Nm	8	8	8	8	8	8
	Starting torque Nm	5.8	5.2	5.6	4.8	5.6	4.8
	Electric braking torque Nm		10/9		10/9		10/9
	Starting current A	8.0	2.4	8.0	2.3	6.4	2.3
	Maximum torque Nm	5.9	5.2	5.7	4.8	5.7	4.8
	Speed at max. torque RPM	1700	0	2040	0	2040	0
	80% of max. torque Nm	4.6	4.1	4.5	3.8	4.5	3.8
	Speed at 80% torque RPM	2400	590	2880	710	2880	710
	Current at 80% torque A	3.9	2.3	3.6	2.3	2.88	2.3
	Inertia kgm ²	0.0012	0.0012	0.0012	0.0012	0.0012	0.0012
	Inertia with flywheel kgm ²	0.0036	0.0036	0.0036	0.0036	0.0036	0.0036
	Power factor, starting	0.90	0.80	0.89	0.78	0.89	0.78
	Weight with fan lb						
	Weight lb	29.8		29.8		29.8	
	No-load current A	2.2	1.7	1.9	1.7	1.52	1.36
	Iron losses W						
	Stator resistance at 20 °C Ω	23	75	23	75	23	75
S3-20%	Speed RPM	2720	590	3370	750	3370	750
	Power hp	1.02	0.24	1.22	0.27	1.22	0.27
	Current A	2.7	1.9	2.7	1.9	2.16	1.52
	Starting burden kgm ² /h	7		4.9		4.9	
	Power factor	0.80	0.67	0.79	0.64	0.79	0.64
	Efficiency	0.57	0.24	0.62	0.26	0.62	0.26
S3-40%	Speed RPM	2720	590	3370	750	3370	750
	Power hp	1.02	0.24	1.22	0.27	1.22	0.27
	Current A	2.7	1.9	2.7	1.9	2.16	1.52
	Starting burden kgm ² /h	6.5		4.5		4.5	
	Power factor	0.80	0.67	0.79	0.64	0.79	0.64
	Efficiency	0.57	0.24	0.62	0.26	0.62	0.26
S3-60%	Speed RPM	2720	590	3370	750	3370	750
	Power hp	1.02	0.24	1.22	0.27	1.22	0.27
	Current A	2.7	1.9	2.7	1.9	2.16	1.52
	Starting burden kgm ² /h	5.8		4		4	
	Power factor	0.80	0.67	0.79	0.64	0.79	0.64
	Efficiency	0.57	0.24	0.62	0.26	0.62	0.26
S3-100%	Speed RPM						
	Power hp						
	Current A						
	Starting burden kgm ² /h						
	Power factor						
	Efficiency						



8 Trolley Speed Tables

8.1 Class I, Division 2

8.1.1 Low Headroom, Contactor Control

Frame	Reeving	ISO Duty	Gear type	Motor type	Total ratio	Whl. dia. [in]	Whl. dia. [mm]	Pcs	50 Hz		60 Hz	
									Spd [fpm]	Spd [m/min]	Spd [fpm]	Spd [m/min]
SX4	021	M4 M5 M6	GEK106PT1B0	MF06LA104	43.7	3.93	100	1	65/15	20/5	75/19	24/6
SX4	041	M4 M5 M6	GEK106PT1B0	MF06LA104	43.7	3.93	100	1	65/15	20/5	75/19	24/6
SX5	021	M4 M5 M6	GEK106PT1B0	MF06LA104	54.8	4.92	125	2	65/15	20/5	75/19	24/6
SX5	041	M5 M6	GEK106PT1B0	MF06LA104	54.8	4.92	125	2	65/15	20/5	75/19	24/6

8.1.2 Normal Headroom, Contactor Control

Frame	Reeving	ISO Duty	Gear type	Motor type	Total ratio	Whl. dia. [in]	Whl. dia. [mm]	Pcs	50 Hz		60 Hz	
									Spd [fpm]	Spd [m/min]	Spd [fpm]	Spd [m/min]
SX4	021	M5 M6	GEK106PT1B0	MF06LA104	43.7	3.93	100	1	65/15	20/5	75/19	24/6
SX4	041	M5 M6	GEK106PT1B0	MF06LA104	43.7	3.93	100	1	65/15	20/5	75/19	24/6
SX4	061	M5 M6	GEK106PT1B0	MF06LA104	43.7	3.93	100	2	65/15	20/5	75/19	24/6
SX4	081	M4	GEK106PT1B0	MF06LA104	43.7	3.93	100	2	65/15	20/5	75/19	24/6
SX5	021	M5 M6	GEK106PT1B0	MF06LA104	43.7	3.93	100	2	65/15	20/5	75/19	24/6
SX5	041	M5 M6	GEK106PT1B0	MF06LA104	43.7	3.93	100	2	65/15	20/5	75/19	24/6
SX5	061	M5	GEK106PT1B0	MF06LA104	54.8	4.92	125	4	65/15	20/5	75/19	24/6
SX5	081	M4	GEK106PT1B0	MF06LA104	54.8	4.92	125	4	65/15	20/5	75/19	24/6
SX6	021/022	M4 M5 M6	GEK106PT1B0	MF06LA104	54.8	4.92	125	2	65/15	20/5	75/19	24/6
SX6	041	M4 M5 M6	GES320PT3B0	MF06LA104	79.6	7.08	180	3	65/15	20/5	75/19	24/6
SX6	042	M4 M5 M6	GEK106PT1B0	MF06LA104	54.8	4.92	125	3	65/15	20/5	75/19	24/6
SX6	061/062	M4 M5 M6	GES320PT3B0	MF06LA104	79.6	7.08	180	3	65/15	20/5	75/19	24/6
SX6	081/082	M5 M6	GES320PT3B0	MF06LA104	79.6	7.08	180	4	65/15	20/5	75/19	24/6

8.1.3 Double Girder, Contactor Control

Frame	Reeving	End truck	Wheel Diameter mm	Wheel Diameter in	Gear Qty	Gear	Motor	Speed 50Hz		Speed 60Hz	
								fpm	m/min	fpm	m/min
SX4	021	RT09	90	3.54	1	GES342	MF06LA104	65/15	20/5	75/19	24/6
SX4	041	RT09	90	3.54	1	GES342	MF06LA104	65/15	20/5	75/19	24/6
SX4	061	RT11	110	4.33	2	GES342	MF06LA104	65/15	20/5	75/19	24/6
SX4	081	RT11	110	4.33	2	GES342	MF06LA104	65/15	20/5	75/19	24/6
SX5	021/022	RT11	110	4.33	2	GES342	MF06LA104	65/15	20/5	75/19	24/6
SX5	041/042	RT11	110	4.33	2	GES342	MF06LA104	65/15	20/5	75/19	24/6
SX5	061/062	RT20	200	7.87	2	GES490	MF06LA104	65/15	20/5	75/19	24/6
SX5	081/082	RT20	200	7.87	2	GES490	MF06LA104	65/15	20/5	75/19	24/6
SX6	021/022	RT20	200	7.87	2	GES490	MF06LA104	65/15	20/5	75/19	24/6
SX6	041/042	RT20	200	7.87	2	GES490	MF06LA104	65/15	20/5	75/19	24/6
SX6	061/062	RT25	250	9.84	2	GES5B5	MF07X-104	65/15	20/5	75/19	24/6
SX6	081/082	RT25	250	9.84	2	GES5B5	MF07X-104	65/15	20/5	75/19	24/6



9 Surface Treatment

9.1 Standard Painting System

	Wet painting		Alternative: Powder coating	
Product group	Steel parts, Load carrying parts	Steel parts, outfitting parts as covers, Aluminium parts	Steel parts, Load carrying parts	Steel parts, outfitting parts as covers, Aluminium parts
Parts and components	End plates Support beam Support of wedge locking Pulley support Hook block Hookd side plate Trolley	Covers Etc.	End plates Support beam Support of wedge locking Pulley support Hook block Hookd side plate Trolley	Covers Etc.
Class	C2M		C2M	
Standard/ Painting system	ISO 12944-5 S2.15 EP120/2-FeSa2½	EP80/1-FeSa2½	ISO 12944 EP/PE 120/1- [color code]	ISO 12944 EP/PE 100/1- [color code]
Steel work	05 (SFS 8145)	05 (SFS 8145)	05 (SFS 8145)	05 (SFS 8145)
Preliminary treatment	Wash, removal of grease Shot blasting Sa2½	Wash, removal of grease Shot blasting Sa2½	Wash, removal of grease Zinc- or ironphosphate	Wash, removal of grease Zinc- or ironphosphate
Priming paint	Epoxy priming paint 1x60 µm			
Finishing paint	Epoxy finishing paint 1x60 µm	Epoxy finishing paint 1x80 µm	Epoxy polyester powder coating 1x100 µm	Epoxy polyester powder coating 1x100 µm
Total paint thickness	120 µm	80 µm	100 µm	100 µm



9.2 Color Codes

Part	Color code
Hoisting unit	
Hoist frame	RAL 7021
Frame cover	RAL 1021
Hoist motor (frame)	Aluminum
Hoist motor (fan cover)	RAL 7021
Hoist gear (frame)	RAL 7021
Junction box	RAL 7021
Rope reeving	
Hook forging	RAL 7021
Cross bar	RAL 7021
Hook sheave cover plate	RAL 1021
Locking plate	RAL 7021
Sheave	RAL 7021
Sheave support	RAL 7021
Rope guide	Yellow passivated ^{*)}
Control enclosure	
Enclosure	RAL 7021
Enclosure support (Low headroom)	RAL 7021
Back plate (Low headroom)	RAL 7021
Counterweight	RAL 7021
Trolley	
Trolley, Double girder	RAL 7021
Trolley (others)	RAL 7021
Traveling machinery	
Travel motor (frame)	Anodised (black)
Travel gear (frame)	
Travel wheel	RAL 7021

EPOXY paint	Color
RAL 7021	Black gray
RAL 9006	Silver
RAL 1021	Cadmium yellow
RAL 1028	Melon yellow

*) Fe/Zn 12 cC ISO R 2081

**) DIN 50961- Fe/Zn 12 A (Colorless)



10 Wire Rope Data

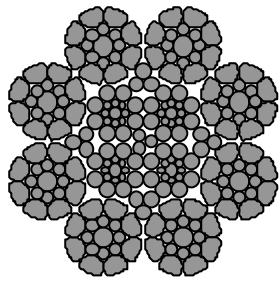

Cross section
Rope type: A

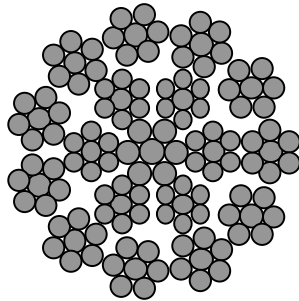

Cross section
Rope type: B

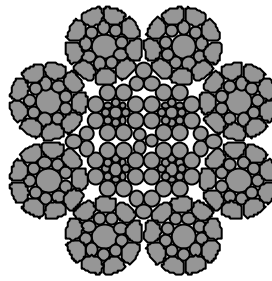

Cross section
Rope type: D and Dr

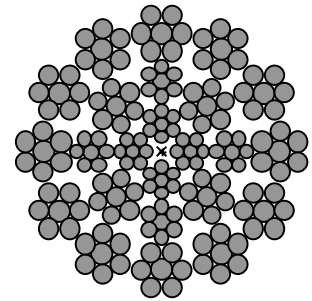

Cross section
Rope type: F and Y

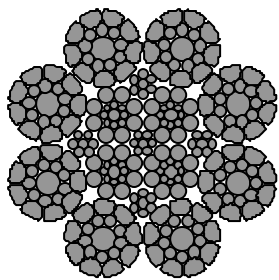

Cross section
Rope type: G and Gr

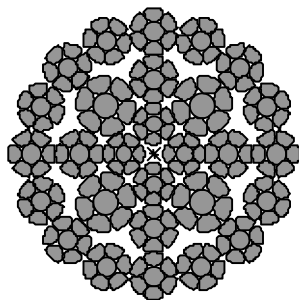

Cross section
Rope type: J, Z and M

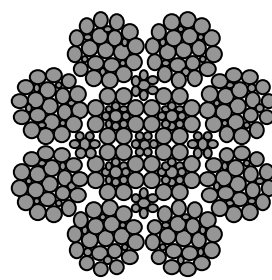

Cross section
Rope type: K and Kr

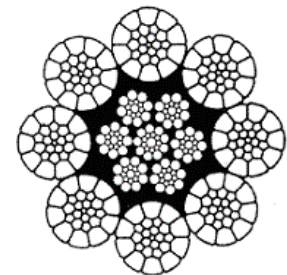

Cross section
Rope type: C, E, Er, H, Hr, L, Lr

Rope	Dia. mm	Minimum Breaking Load kN	Calculated Braking Load kN	Strand Constr.	Wire Strength N/mm ²	Core	Rope Lay	Comp. Outer Strands	Wire Material	Weight lb/ft	Rot. resist.
A	6.2	36.4	45.5	8 x 17	2160	Steel core parallel strands	LR	Yes	Galvanized steel	0.11	No
B	6.7	37.0	47.4	17 x 7	2160	Steel core	LR	No	Galvanized steel	0.12	Yes
D	8.0	65.6	73.0	8 x 19	2160	Steel core parallel strands	LR	Yes	Galvanized steel	0.20	No
Dr	8.0	65.6	73.0	8 x 19	2160	Steel core parallel strands	RR	Yes	Galvanized steel	0.20	No
F	8.0	56.0	66.0	24 x 7	2160	Steel core	LL	No	Galvanized steel	0.18	Yes
Y	8.5	63.5	80.0	24 x 7	2160	Steel core	LL	No	Galvanized steel	0.22	Yes
G	11.0	128	141.4	8 x 19	2160	Steel core parallel strands	LR	Yes	Galvanized steel	0.38	No
Gr	11.0	128	141.4	8 x 19	2160	Steel core parallel strands	RR	Yes	Galvanized steel	0.38	No
J	11.0	115.0	137.3	28 x 7	2160	Steel core	LR	Yes	Galvanized steel	0.38	Yes
Z	11.5	125.0	150.3	28 x 7	2160	Steel core	LR	Yes	Galvanized steel	0.41	Yes
K	15.0	221.6	257.5	8 x 25	2160	Steel core parallel strands	LR	No	Galvanized steel	0.69	No
Kr	15.0	221.6	257.5	8 x 25	2160	Steel core parallel strands	RR	No	Galvanized steel	0.69	No
M	15.0	218	249.0	28 x 7	2160	Steel core	LR	Yes	Galvanized steel	0.69	Yes
C	6.5	36.7	43.2	8 x 19	1960	Independent wire rope core	LR	Yes	Galvanized steel	0.13	No
E	8.0	65.6	78.1	8 x 19	2160	Independent wire rope core	LR	Yes	Galvanized steel	0.22	No
Er	8.0	65.6	78.1	8 x 19	2160	Independent wire rope core	RR	Yes	Galvanized steel	0.22	No
H	11.0	128	152	8 x 19	2160	Independent wire rope core	LR	Yes	Galvanized steel	0.42	No
Hr	11.0	128	152	8 x 19	2160	Independent wire rope core	RR	Yes	Galvanized steel	0.42	No
L	15.0	229	273	8 x 26	2160	Independent wire rope core	LR	Yes	Galvanized steel	0.76	No
Lr	15.0	229	273	8 x 26	2160	Independent wire rope core	RR	Yes	Galvanized steel	0.76	No

LR = left hand regular lay
 RR = right hand regular lay
 LL = left hand Lang's lay



11 Materials

Part	Fabrication method							Material								Material		Standard Finishing			
	1	2	3	4	5	6	7	1	2	3	4	5	6	7	8	Description	Standard	1	2	3	4
HOIST FRAME																					
Drum						•	•									S355J2G3	EN10025				
Rope guide	•						•					•				EN-GJS-500	EN1563	•			
Frame rods							•									S355J2G3	EN10025	•			
Frame ends, SX2-SX5				•												S355MC	EN10149	•			
Frame ends, SX6				•			•									S355J2G3	EN10025	•			
Frame protection cover				•								•				DC01	EN10130	•			
Electric enclosure	•														•						
Drum seal ring																POM					
Junction box																PPE+S/B					
ROPE SHEAVE ASSEMBLIES																					
Rope sheaves	•						•									EN-GJS-700	EN1563	•			
Rope sheave shafts							•					•				S355J2G3	EN10025		•		
Suspension beam					•	•						•				S355J2G3	EN10025	•			
ROPE ANCHORAGE																					
Rope clamps							•									S355J2G3	EN10025			•	
Rope anchorage housing	•														•	EN-GJS-500	EN1563	•			
Rope anchorage wedge	•														•	EN-GJS-500	EN1563	•			
Rope anchorage shaft							•								•	S355J2G3	EN10025		•		
HOOK																					
Hook forging		•					•								•	34CrMo4QT	EN10083	•			
Hook forging		•					•								•	34CrNiMo6QT	EN10083	•			
Hook block housing, SX2-SX5, when 041 rope falls!!				•											•	S355MC	EN10149	•			
Hook block housing							•								•	S355J2G3	EN10025	•			
Sheave cover				•											•	DC03	EN10130	•			
HOISTING GEARBOX																					
Gearbox housing, SX2-SX4	•						•								•	G-AISI7Mg	EN1706	•			
Gearbox housing, SX5-SX6	•						•								•	EN-GJS-500	EN1563	•			
Gear wheels							•								•	AISI 8620	AISI 8620				
Shafts inside gearbox							•								•	AISI 8620	AISI 8620				
Coupling							•								•	S355J2G3	EN10025				
HOISTING MOTORS																					
Motor frame			•				•								•	AlMgSi-T5	EN573				
Rotor shaft							•								•	42CrMo4QT	EN10083				
Mounting flange	•						•								•	G-AISI10Mg	EN1706				
Mounting flange, motor MF13	•						•								•	EN-GJL-200	EN1561	•			
TRAVELING GEARBOX																					
Gearbox housing	•						•								•	G-AISI10Mg	EN1706	•			
Gear wheels							•								•	AISI 8620	AISI 8620				
Gearbox shafts							•								•	AISI 8620	AISI 8620				
TRAVELING MOTOR																					
Motor frame			•				•								•	AlMgSi-T5	EN573				
Rotor shaft							•								•	42CrMo4QT	EN10083				
Mounting flange	•						•								•	G-AISI10Mg	EN1706				



Part	Fabrication method							Material								Material		Standard Finishing			
	1	2	3	4	5	6	7	1	2	3	4	5	6	7	8	Description	Standard	1	2	3	4
LOW HEADROOM TROLLEY																					
Frame beams						•		•								S355J2G3	EN10025		•		
Frame plates				•		•		•								S355J2G3	EN10025	•			
Travel wheel shafts						•		•								S355J2G3	EN10025				
Travel wheels	•												•			EN-GJS-700	EN1563	•			
Counter weight					•			•								S235JRG2	EN10025	•			
NORMAL HEADROOM TROLLEY																					
Trolley plates					•	•		•								S355J2G3	EN10025	•			
Trolley suspension frame					•	•		•								S355J2G3	EN10025	•			
Trolley suspension shaft. b<420mm							•						•			S355J2G3	EN10025		•		
Trolley suspension shaft, b>420mm							•						•			42CrMo4QT	EN10083		•		
Travel wheels	•													•		EN-GJS-700	EN1563	•			
Travel wheel shafts							•		•							S355J2G3	EN10025				
DOUBLE GIRDER TROLLEY																					
Trolley wheels	•													•		EN-GJS-700	EN1563	•			
Trolley wheel shafts (if any)							•		•							S355J2G3	EN10025				
Trolley wheel supports (if any)	•													•		EN-GJS-500	EN1563	•			
Trolley end carriages							•		•							S275JR	EN10025	•			
Intermediate beam							•		•							S355J2G3	EN10025	•			
SPARK RESISTANT OPTION																					
Trolley wheels							•									CuZn19Al6					
Bronze coated hook (60µm)							•									CuZn40Pb3					
Safety lugs							•									CuZn40Pb3					



12 Load Block

12.1 Load Block Dimensions – U.S. units

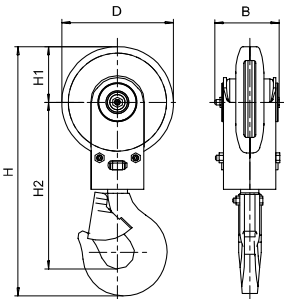

Figure 1

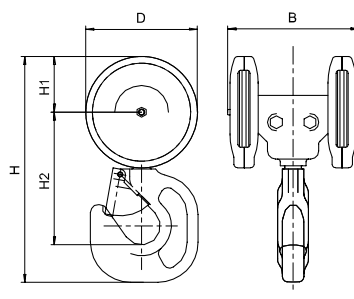

Figure 2

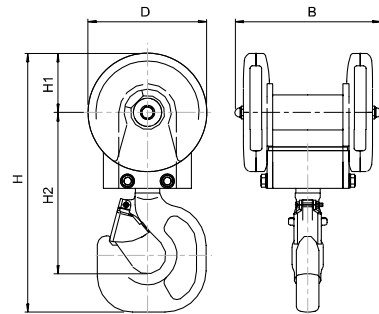

Figure 3

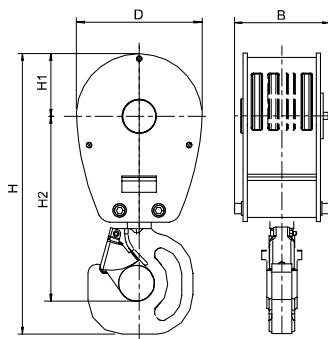

Figure 4

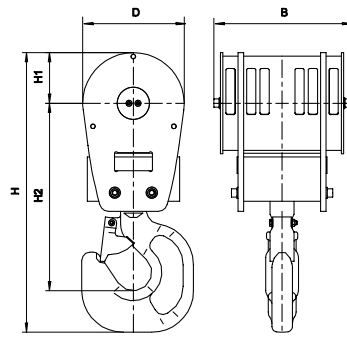

Figure 5

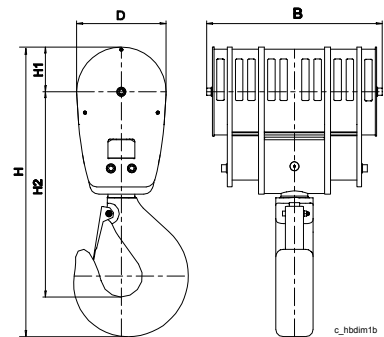

Figure 6

Hoist frame	Rope falls	FEM/ISO Hoist duty			Hook forging	Fig.	Hook block dimensions (in)					Weight (lb)
		1Am/M4	2m/M5	3m/M6			H	H1	H2	D	B	
SX4	021		M5	M6	RSN 1 V	1	16.30	4.02	10.71	8.03	4.65	31
SX4	041		M5	M6	HBC 2.5 V	2	16.77	4.02	10.20	8.03	10.63	48
SX4	061		M5		HBC 2.5 V	4	19.65	4.33	12.76	8.66	6.50	82
SX4	081	M4			HBC 2.5 V	4	19.65	4.33	12.76	8.66	6.50	88
SX5	021		M5	M6	HBC 2.5 V	1	22.76	5.59	14.61	11.14	5.20	68
SX5	041		M5	M6	HBC 5 V	2	21.54	5.59	12.44	11.14	14.80	103
SX5	061		M5		HBC 5 V	4	27.05	5.91	17.60	11.81	8.66	194
SX5	081	M4	M5		HBC 5 V	4	27.05	5.91	17.60	11.81	8.66	209
SX5	022		M5	M6	HBC 2.5 V	4	19.65	4.33	12.76	8.66	6.50	64
SX5	042		M5	M6	HBC 5 V	5	23.94	4.33	16.06	8.66	8.66	148
SX5	062		M5	M6	HBC 5 V	5	25.35	4.33	17.64	8.66	11.65	172
SX5	082	M4	M5		HBC 5 V	5	25.35	4.33	17.64	8.66	13.94	190
SX6	021	M4	M5	M6	HBC 5 V	4	31.02	7.80	19.69	15.55	8.62	207
SX6	041	M4	M5	M6	HBC 5 V	4	31.02	7.80	19.69	15.55	8.62	234
SX6	061	M4	M5		RSN10 T	4	36.61	7.80	24.61	15.55	10.20	401
SX6	081	M4			RSN 16 T	5	42.01	7.80	28.94	15.55	11.38	553
SX6	022	M4	M5	M6	HBC 5 V	4	27.04	5.91	17.60	11.81	8.66	198
SX6	042	M4	M5	M6	HBC 5 V	4	27.04	5.91	17.60	11.81	8.66	209
SX6	062	M4	M5		RSN10 T	5	33.23	5.91	23.11	11.81	14.69	357
SX6	082	M4			RSN 16 T	6	38.35	5.91	27.17	11.81	19.02	489

12.2 Load Block Dimensions – Metric units

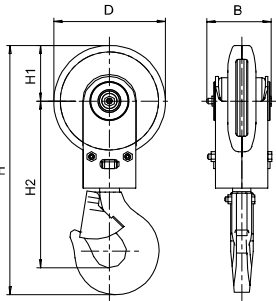

Figure 1

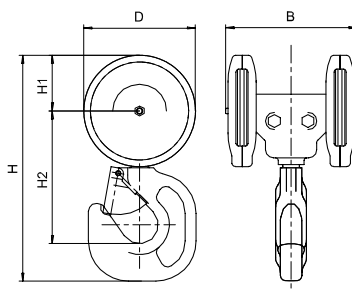

Figure 2

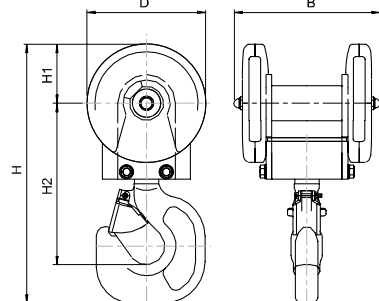

Figure 3

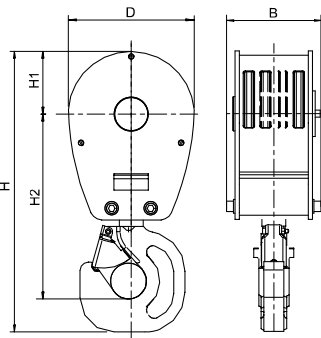

Figure 4

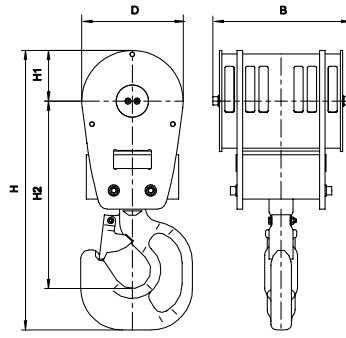

Figure 5

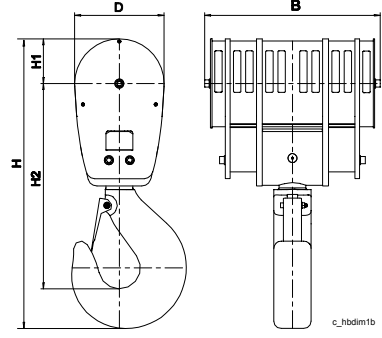
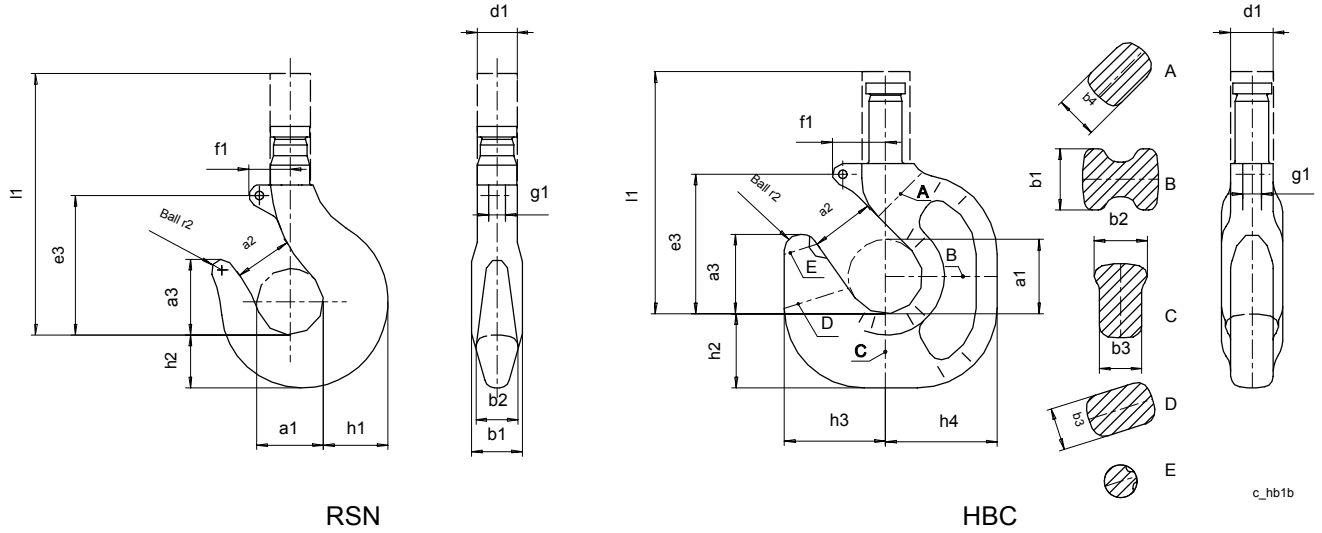

Figure 6

Hoist frame	Rope falls	FEM/ISO Hoist duty			Hook forging	Fig.	Hook block dimensions (mm)					Weight (kg)
		1Am/M4	2m/M5	3m/M6			H	H1	H2	D	B	
SX4	021		M5	M6	RSN 1 V	1	414	102	272	204	118	14
SX4	041		M5	M6	HBC 2.5 V	2	426	102	259	204	270	21.8
SX4	061		M5		HBC 2.5 V	4	499	110	324	220	165	37
SX4	081	M4			HBC 2.5 V	4	499	110	324	220	165	40
SX5	021		M5	M6	HBC 2.5 V	1	578	142	371	283	132	31
SX5	041		M5	M6	HBC 5 V	2	547	142	316	283	376	46.5
SX5	061		M5		HBC 5 V	4	687	150	447	300	220	88
SX5	081	M4	M5		HBC 5 V	4	687	150	447	300	220	95
SX5	022		M5	M6	HBC 2.5 V	4	499	110	324	220	165	29
SX5	042		M5	M6	HBC 5 V	5	608	110	408	220	220	67
SX5	062		M5	M6	HBC 5 V	5	644	110	448	220	296	78
SX5	082	M4	M5		HBC 5 V	5	644	110	448	220	354	86
SX6	021	M4	M5	M6	HBC 5 V	4	788	198	500	395	219	94
SX6	041	M4	M5	M6	HBC 5 V	4	788	198	500	395	219	106
SX6	061	M4	M5		RSN10 T	4	930	198	625	395	259	182
SX6	081	M4			RSN 16 T	5	1067	198	735	395	289	264
SX6	022	M4	M5	M6	HBC 5 V	4	687	150	447	300	220	90
SX6	042	M4	M5	M6	HBC 5 V	4	687	150	447	300	220	95
SX6	062	M4	M5		RSN10 T	5	844	150	587	300	373	177
SX6	082	M4			RSN 16 T	6	974	150	690	300	483	292



12.3 RSN and HBC Hook Dimensions – U.S. Units



inch	RSN										HBC		
	RSN 1	RSN 1.6	RSN 2.5	RSN 4	RSN 5	RSN 6	RSN 10	RSN 16	RSN 20	RSN 25	HBC 1.6	HBC 2.5	HBC 5
a ₁	1.97	2.20	2.48	2.80	3.15	3.54	4.41	5.51	6.30	7.09	2.20	2.48	3.15
a ₂	1.57	1.77	1.97	2.20	2.48	2.80	3.15	4.41	4.92	5.51	1.77	1.93	2.48
a ₃	2.24	2.52	2.83	3.15	3.54	3.98	5.00	6.30	7.09	7.95	2.36	2.56	3.31
b ₁	1.50	1.77	2.09	2.48	2.80	3.15	3.94	4.92	5.51	6.30	1.81	2.09	2.80
b ₂	1.26	1.50	1.77	2.09	2.36	2.64	3.35	4.17	4.65	5.20	1.57	1.77	2.36
b ₃	-	-	-	-	-	-	-	-	-	-	1.26	1.50	2.17
b ₄	-	-	-	-	-	-	-	-	-	-	1.26	1.50	1.77
d ₁	1.18	1.42	1.65	1.89	2.09	2.36	2.95	3.74	4.17	4.65	1.50	1.73	2.17
e ₃	4.13	4.65	5.20	5.83	6.50	7.28	8.70	11.05	12.99	14.17	4.13	4.65	5.83
f ₁	1.22	1.38	1.57	1.77	2.01	2.24	1.81	2.28	2.68	2.91	1.57	1.77	2.07
g ₁	0.49	0.55	0.63	0.63	0.71	0.71	0.98	1.38	1.38	1.57	0.55	0.63	0.71
h ₁	1.89	2.20	2.64	3.15	3.54	3.94	4.92	6.30	7.09	7.87	-	-	-
h ₂	1.57	1.89	2.28	2.64	2.95	3.35	4.17	5.20	5.91	6.69	2.20	2.56	3.54
h ₃	-	-	-	-	-	-	-	-	-	-	2.99	3.35	4.41
h ₄	-	-	-	-	-	-	-	-	-	-	3.31	3.94	5.12
l ₁	7.76	8.27	9.96	11.22	12.52	14.72	18.11	23.43	26.18	28.94	7.83	10.24	11.42
r ₂	0.31	0.35	0.39	0.47	0.55	0.63	0.79	0.98	1.10	1.26	0.47	0.59	0.71
weight (forging)	7 lb	10 lb	14 lb	19 lb	27 lb	38 lb	88 lb	170 lb	247 lb	353 lb	11 lb	18 lb	33 lb

Note: Safety latch decreases dimension a₂ about 0.2 in. on HBC forging and about 0.6 in. on RSN forging.

	Hook forging standard	
	RSN	HBC
Dimension standard	DIN 15401	Oversized DIN 15401
Material standard	DIN 15400	DIN 15400



12.4 RSN and HBC Hook Dimensions – Metric Units

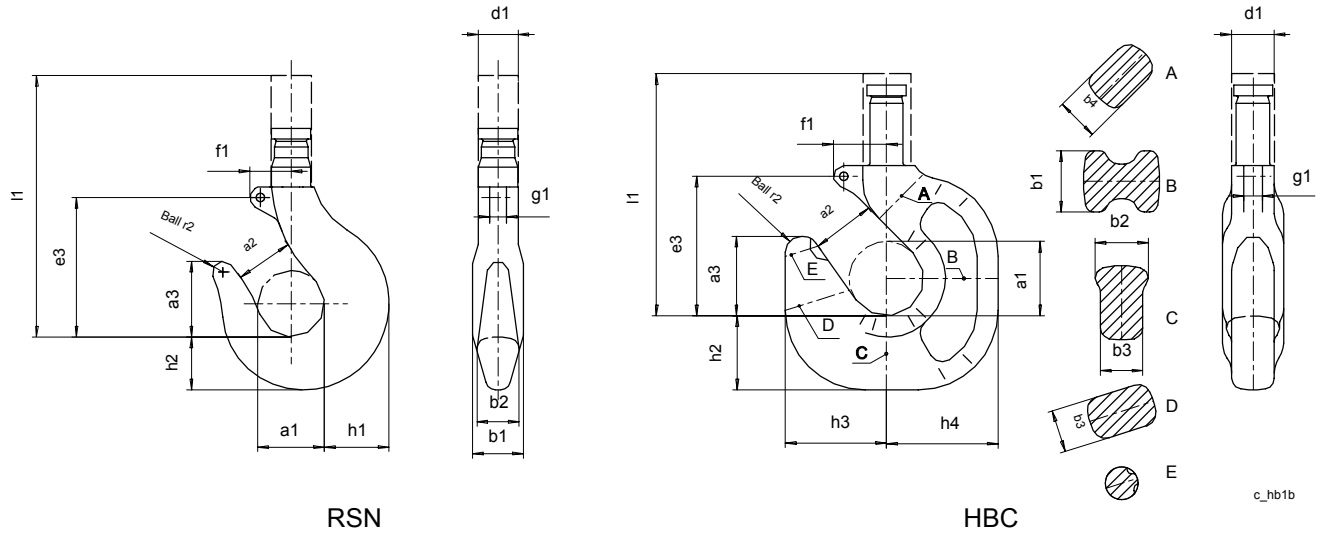

RSN

HBC

c_hb1b

mm	RSN										HBC		
	RSN 1	RSN 1.6	RSN 2.5	RSN 4	RSN 5	RSN 6	RSN 10	RSN 16	RSN 20	RSN 25	HBC 1.6	HBC 2.5	HBC 5
a ₁	50	56	63	71	80	90	112	140	160	180	56	63	80
a ₂	40	45	50	56	63	71	80	112	125	140	45	49	63
a ₃	57	64	72	80	90	101	127	160	180	202	60	65	84
b ₁	38	45	53	63	71	80	100	125	140	160	46	53	71
b ₂	32	38	45	53	60	67	85	106	118	132	40	45	60
b ₃	-	-	-	-	-	-	-	-	-	-	32	38	55
b ₄	-	-	-	-	-	-	-	-	-	-	32	38	45
d ₁	30	36	42	48	53	60	75	95	106	118	38	44	55
e ₃	105	118	132	148	165	185	221	280	330	360	105	118	148
f ₁	31	35	40	45	51	57	46	58	68	74	40	45	52.5
g ₁	12.5	14	16	16	18	18	25	35	35	40	14	16	18
h ₁	48	56	67	80	90	100	125	160	180	200	-	-	-
h ₂	40	48	58	67	75	85	106	132	150	170	56	65	90
h ₃	-	-	-	-	-	-	-	-	-	-	76	85	112
h ₄	-	-	-	-	-	-	-	-	-	-	84	100	130
l ₁	197	210	253	285	318	374	460	595	665	735	199	260	290
r ₂	8	9	10	12	14	16	20	25	28	32	12	15	18
weight (forging)	3.2 kg	4.5 kg	6.3 kg	8.8 kg	12.3 kg	17.1 kg	40 kg	77 kg	112 kg	160 kg	5.1 kg	8 kg	15 kg

Note: Safety latch decreases dimension a₂ about 5 mm on HBC forging and about 15 mm on RSN forging.



13 Drum and Rope Sheave

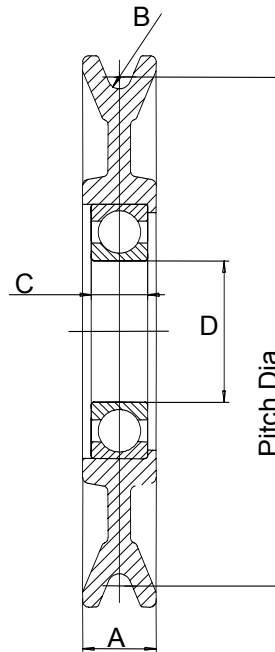

13.1 Bottom Block Sheave Dimensions

Frame Size	Reeving	Rope diameter		Sheave Pitch Dia.		A		B (radius)		C		D	
		mm	in	mm	in	mm	in	mm	in	mm	in	mm	
SX4	Single	8	7.09	180	1.02	25.9	0.17	4.2	0.79	20.1	1.97	50	
SX5	Single	11	9.76	248	1.26	32	0.23	5.8	0.91	23.1	2.56	65	
SX5	Double	8	7.09	180	1.02	25.9	0.17	4.2	0.79	20.1	1.97	50	
SX6	Single	15	13.31	338	1.57	39.9	0.31	8	1.10	27.9	3.35	85	
SX6	Double	11	9.76	248	1.26	32	0.23	5.8	0.91	23.1	2.56	65	

13.2 Drum and Frame Sheave Dimensions

Frame Size	Reeving	Rope diameter		Drum pitch dia.		Rope drum pitch		Sheave pitch dia.		Number of rope clamps on drum
		mm	in	mm	in	mm	in	mm	in	
SX4	Single	8	13.98	355	0.36	9.1	7.09	180	3	
SX5	Single	11	15.98	406	0.49	12.4	9.76	248	4	
SX5	Double	8	15.98	406	0.36	9.1	7.09	180	3 on each end	
SX6	Single	15	23.94	608	0.67	17	13.31	338	6	
SX6	Double	11	23.94	608	0.49	12.4	9.76	248	4 on each end	

Authorized Sales & Service
J. HERBERT CORPORATION
 Call 1-800-255-0588
 407-846-0588 Fax: 846-1066
 info@jherbertcorp.com

 Visit us online:
www.jherbertcorp.com