

Authorized Sales & Service
J. HERBERT CORPORATION
Call 1-800-255-0588
407-846-0588 Fax: 846-1066
info@jherbertcorp.com

Visit us online:
www.jherbertcorp.com

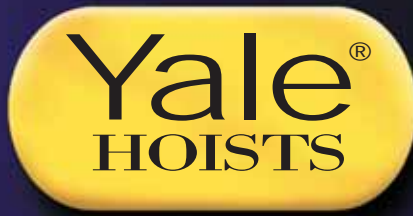

Cable King™ Wire Rope Electric Hoists



AMERICA'S FIRST NAME IN INDUSTRIAL LIFTING

Cable King™ Electric Wire Rope Hoists

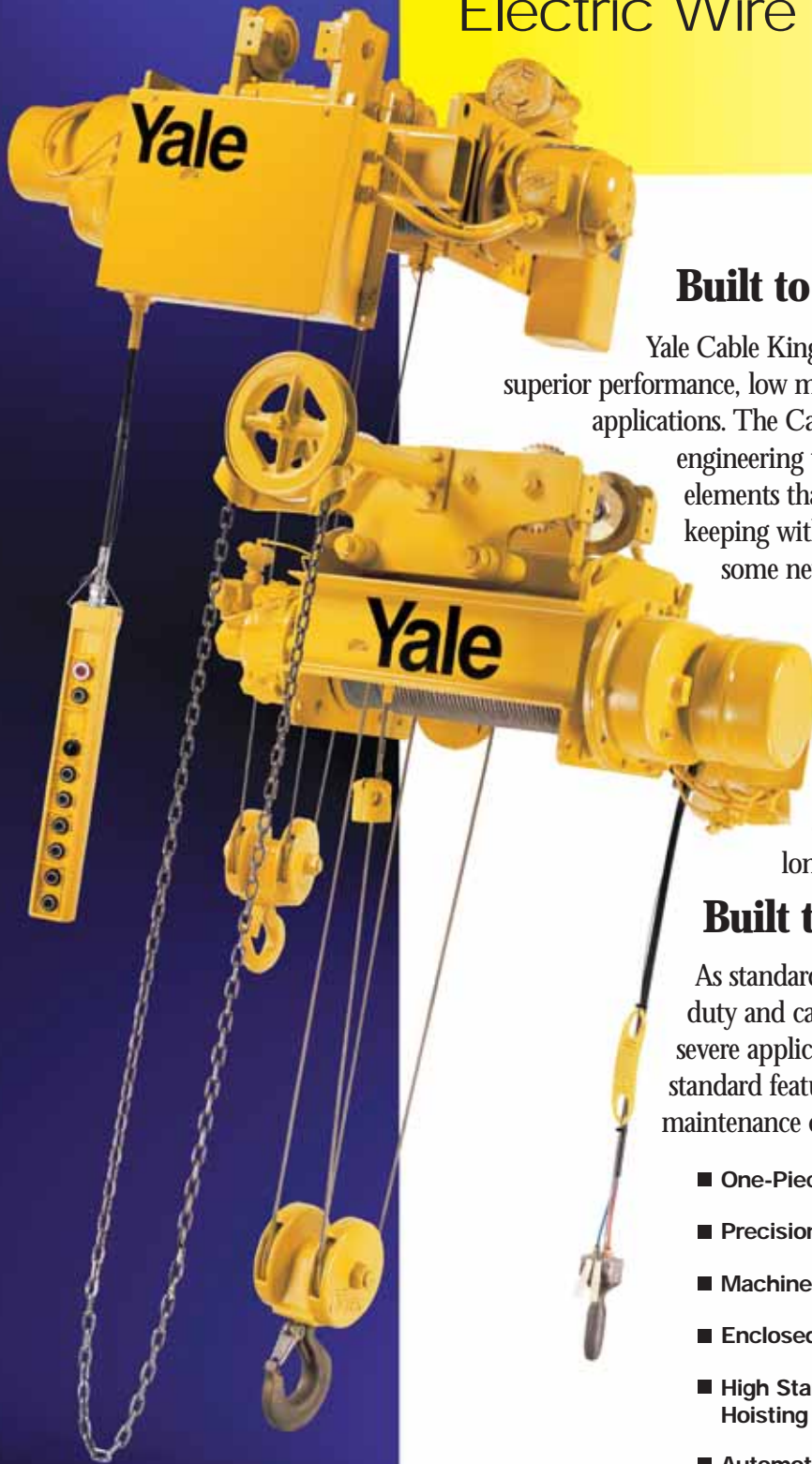

Built to last.

Yale Cable King hoists have a well-deserved reputation for superior performance, low maintenance, and longevity in heavy-duty applications. The Cable King hoist is the result of years of engineering that builds on time tested design elements that have proven so successful in the past. And in keeping with our innovative tradition, we incorporated some new ones. The result is a hoist line that lives up to our own tough standards of dependability and durability. And with the capability of longer lifts and greater capacities, you'll find a Yale hoist to fit your needs and receive more value for your investment. When you buy a Cable King hoist, you buy it with confidence that it will be on the job for a long time to come.

Built to perform.

As standard, Cable King hoists are rated for Class H-4 duty and can be configured for Class H-5 duty for more severe applications. Cable King hoists are also loaded with standard features that enhance performance, reduce maintenance costs and increase longevity. Features such as:

- One-Piece Welded Steel Frame
- Precision Spur Gearing
- Machined Steel Rope Drum
- Enclosed Bottom Blocks with 360° Hook Rotation
- High Starting Torque Motor Designed Especially for Hoisting Service
- Automotive-Type Drive Shaft for a smooth running, long-lasting drive
- Weston Screw-Type Load Brake and Disk-Type AC Motor Brakes
- Wide Variety of Controls
- Upper and Lower Adjustable and Upper Block-Operated Control Circuit Limit Switches

With Yale hoists,
quality is not an option,
it is standard.

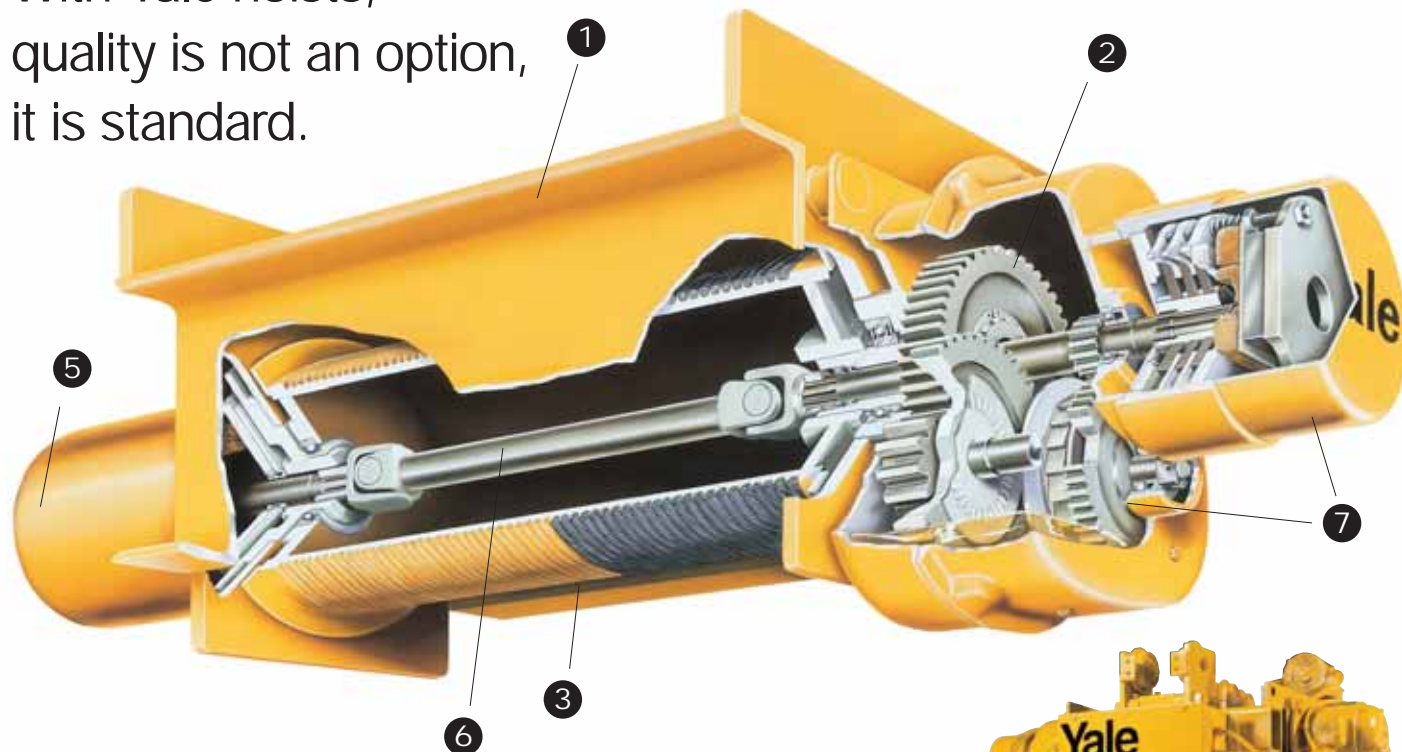

Inside the Cable King

Some of the standard features of the Cable King are:

- 1 **Frame**
One-piece welded steel made from heavy structural shapes provides a rugged, and durable foundation for precise mounting and alignment of the hoisting machinery.
- 2 **Gearing**
Precision spur gearing machined from high-alloy steel or drop forgings is case hardened for quiet operation and long life. Gearing operates in a precision machined ductile iron or steel gearcase and is oil bath lubricated.
- 3 **Rope Drum**
Fabricated steel drum machined with grooving cuts up to 50% of the rope's diameter to guard against the rope jumping out of the groove, which can damage and weaken the rope.
- 4 **Bottom Blocks**
Enclosed blocks with 360 degree hook rotation. All hooks provided with a spring loaded hook latch as standard.
- 5 **Motors**
High starting torque made especially for hoisting service. The motors are TENV, 30-minute rated with class F insulation and thermostats as standard.
- 6 **Automotive-type drive shaft**
Borrowing from the automotive industry, Cable King hoists incorporated a smooth running, long-lasting drive shaft for effective power transmission from the motor to the drive gearing.
- 7 **Brakes**
Weston screw-type load control brake and disk-type AC motor brake rated at a minimum 125% of the motor's torque.
- 8 **Controls**
One and two speed and variable frequency housed in a NEMA 12 enclosure as standard. The 115-volt control circuit is fused.
- 9 **Limit Switch**
As standard an upper and lower adjustable geared control circuit limit switch is provided along with an upper block-plugging limit switch.

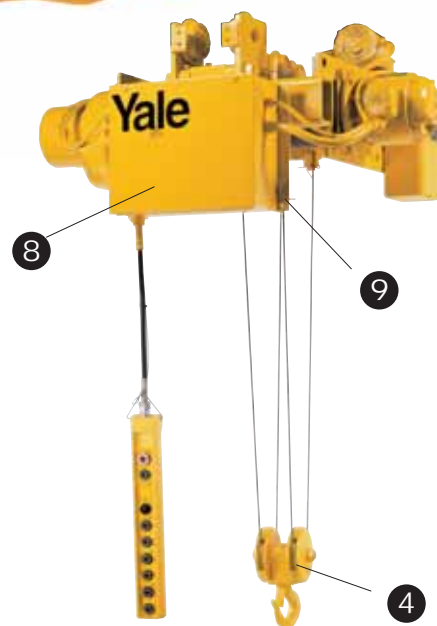

- 1/2 to 35-ton capacity
- Designed and built to meet the standards of HMI, ASME and NEC
- Available in monorail, base, and deck mounted and top-running versions
- Available for air operation
- Available in spark resistant and explosion proof versions

Optional Features

- Non-cataloged lifts and speeds
- Hot metal applications
- Car shaker applications
- Bucket hoists
- Marine duty offshore applications
- Special paint finishes
- Winch applications

Cable King Standard and Optional Features



Gearing
Precision spur machined from high-alloy steel or drop forgings and case hardened for long life and quiet operation. Gearing operates in a precision machined ductile iron or steel gearcase and is continuous oil bath lubricated to reduce maintenance and increase life.



Mechanical Load Brake
Fully automatic in operation and adjustment. Weston design load control brake operates with or without power.



Wire Rope Drum
Drums are fabricated from steel tubing and grooved to a depth of up to 50% of the rope's diameter to guard against the rope jumping out of the groove, which can damage and weaken the rope.



Motors
Cable King motors are high starting torque built especially for hoisting applications. These high quality motors come standard as 30-minute rated with Class F insulation and thermal overloads built into the windings.



AC Motor Brake
The Cable King uses an AC-type gearcase mounted disc brake. Its features include precise load spotting capabilities and more efficient power consumption than other types of hoisting brakes. Electrically released and spring set, the brake operates automatically upon loss of power.



Upper Block-Operated Limit Switch (Except Winches)
In addition to the geared limit switch, an upper block-operated control circuit limit switch is provided as standard. The limit switch is activated by the lower block and contains a reverse plugging feature that will momentarily reverse the direction of the hoist if the block continues to travel too high.



Geared Limit Switch
Heavy-duty, adjustable geared upper and lower control circuit limit switch is standard on all Cable King hoists.



Trolleys
Yale Cable King hoists are available with hand-push, hand-gear or motor-driven trolleys for use on wide-flange, I-beam or patented track.



SpaceVector Variable Frequency Drives
Optional variable frequency drives are available for hoisting and traverse motions. Variable frequency drives provide smoother acceleration and deceleration, less load swing and impact on the drive train and allow the motors to run cooler improving load handling and extending equipment life.

A story of innovation

In 1875 Linus Yale invented the “Differential Hoist” which started the modern hoisting industry in the United States and the company known today as Yale Hoists. Since the beginning, Yale has been synonymous with quality, durability and innovation. In 1879, a Yale engineer, Thomas Weston, invented the Weston Screw Load Brake, a mechanical load control brake, of which modern versions are still the industry standard today. Since the late 19th Century, scarcely a year has gone by without new, better hoists and improved features being introduced. In 1938, Frank Locke, an engineer recruited from the Krupp Works in Germany, developed the Cable King hoist. The Cable King was the first large capacity electric wire rope monorail hoist and is the predecessor of the modern Cable King line sold today.

The momentum that started over a century ago continues today at the Yale facility in Forrest City, Arkansas. Yale



*Yale Works, 1920
Stamford, Connecticut*

hoists are used in every country of the world in every kind of application imaginable. Quality, time-tested hoists for standard and special applications are the hallmarks of Yale. Yale hoists are sold through a worldwide organization of dealers. Parts and service depots are found in all major metropolitan areas around the globe. Well into its second century of existence, Yale is committed to maintaining the role as industry innovator and leader.

Yale

Authorized Sales & Service

J. HERBERT CORPORATION

Call 1-800-255-0588

407-846-0588 Fax: 846-1066

info@jherbertcorp.com

Visit us online:

www.jherbertcorp.com

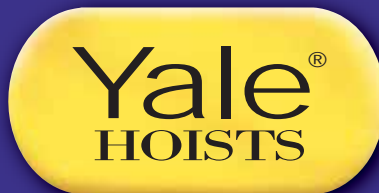

⚠ WARNING

To Avoid Injury:

- Do not exceed working load limit, load rating, or capacity.
- Do not use to lift people or loads over people.
- Read and follow all instructions.

For additional information contact your Yale representative or Yale headquarters direct.
3105 N. Washington • P.O. Box 1000 • Forrest City, Arkansas 72335-1000
PH 800-999-6318 or 870-633-2250 • FX 800-766-0223

PRINTED IN U.S.A. / COPYRIGHT 1999, YALE® HOISTS, DIVISION OF COLUMBUS MCKINNON CORPORATION / BULLETIN NO Y/L-1001-1099

