

High Performance Lifting

COFFING® HOISTS

Plain or Geared Trolleys — Enhanced Design Requires Less Effort, Superior Performance

The Coffing CT-A Trolleys feature enhanced design, available in plain and geared models, which can be modified to fit a wide range of beam sizes and styles. The CT-A is designed to provide easy operation and superior performance in industrial lifting applications.

- **Capacities** - Rated loads from 1/4 to 5 tons in plain and geared models. Geared trolleys have standard 6-foot hand chain drop. Other hand chain drops available.
- **Rugged** - Designed to provide superior performance and long, efficient service.
- **Easy Operation** - Lowest rolling effort in the Coffing trolley line.
- **Universal Mounting** - Clevis accepts all Coffing hook-mounted hoists, or lug-mounted hoists attached directly to load pins.
- **Increased Adjustable** - Trolley easily conforms to any beam flange within range of adjustment. For larger flange width, please consult factory.
- **Wrap-Around Side Plates** - Lugs provide additional security for operator and act as bumpers to protect wheels.
- **Dual Tread Wheels** - Fully machined wheels fit any tapered or flat flanged beams within range of adjustment. Wheels include permanently lubricated, shielded ball bearings for long life and low maintenance.
- **Options** - Spark resistant and corrosion resistant wheels available. Track clamps available on 1/4 to 4 ton models.
- **Made In USA**



1/4 - 5 Ton

Made In
USA

SPECIFICATIONS

1/4 - 5 Ton

Capacity (Lb.)	Capacity (Ton)	Model Number	Standard Beam Height (In.)	Beam Width (In.)	Min. Radius Curve (In.)	Net Weight (P) (Lbs.)	Net Weight (G) (Lbs.)
500	1/4	CTA-05P(G)	6 - 18	3.33 - 7.00	48	46	52
1000	1/2	CTA-10P(G)	6 - 18	3.33 - 7.00	48	46	52
2000	1	CTA-20P(G)	6 - 18	3.33 - 7.00	48	46	52
4000	2	CTA-40P(G)	6 - 18	3.33 - 7.00	48	46	52
6000	3	CTA-60P(G)	6 - 18	3.33 - 7.00	48	46	52
8000	4	CTA-80P(G)†	8 - 18	4.00 - 7.00	**	125	130
10000	5	CTA-100P(G)†	8 - 18	4.00 - 7.00	**	125	130

* When Ordering Specify "P" for plain trolley or "G" for geared trolley

** Standard model for straight track only. Articulating model for 4-foot minimum radius curve available -Consult Factory

† Eight-wheel trolley design reduces beam flange stress. **NOTE:** for complete dimensional data, refer to Coffing Dimensional Databook

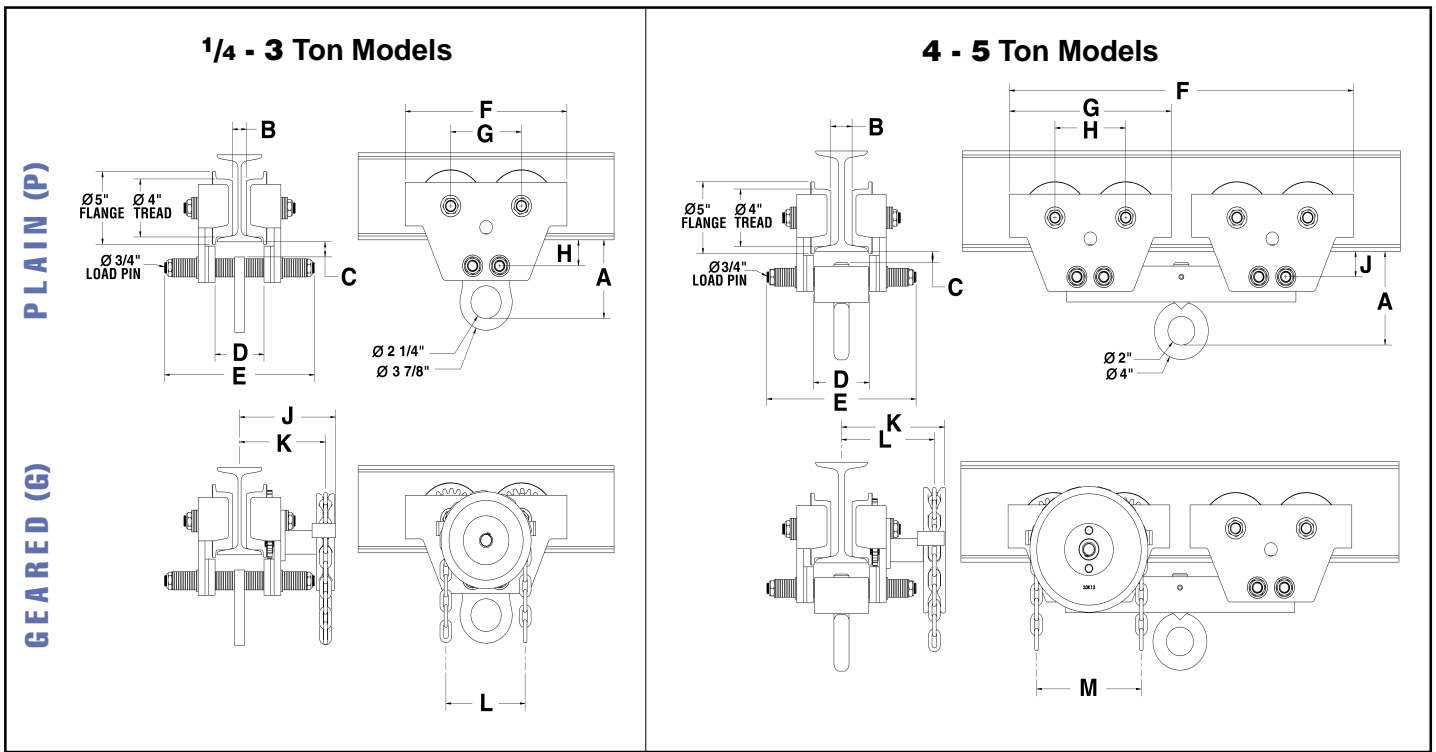

C L E A R A N C E D I M E N S I O N S (I n .)

Capacity (Tons)	A	B	C	D	E	F	G	H	J	K	L	M
1/4 - 3	5 ¹³ / ₃₂	1 ¹ / ₁₆	1 ¹ / ₃₂	3 ⁵ / ₈	11 ¹ / ₈	12	5 ¹ / ₄	1 ²⁵ / ₃₂	7 ¹ / ₈	6 ³ / ₈	5 ⁷ / ₈	—
4 - 5	6 ¹⁷ / ₃₂	1 ¹⁹ / ₃₂	2 ⁵ / ₃₂	4 ⁵ / ₃₂	11 ¹ / ₈	25 ¹ / ₂	12	5 ¹ / ₄	1 ²⁵ / ₃₂	7 ¹¹ / ₁₆	6 ²⁹ / ₃₂	7 ²⁵ / ₃₂



⚠ WARNING

Overloading and Improper Use Can Result In Injury

To Avoid Injury:

- Do not exceed working load limit, load rating, or capacity.
- Do not use to lift people or loads over people.
- Use only alloy chain and attachments for overhead lifting.
- Read and follow all instructions.

High Performance Lifting

COFFING®
HOISTS

Country Club Road • PO Box 779
Wadesboro, NC 28170 USA

Phone: (800) 477-5003 (704) 694-2156
FAX: (800) 374-6853 (704) 694-6829

www.coffinghoists.com e-mail: coffing@cmworks.com

Authorized Sales & Service
J. HERBERT CORPORATION
Call 1-800-255-0588
407-846-0588 Fax: 846-1066
info@jherbertcorp.com

Visit us online:
www.jherbertcorp.com