

CB-22

Model TB-602

High Performance Lifting

COFFING[®]
HOISTS

This Handy Mini-Hoist Lifts Up to 550 Lbs. Convenient Toolbox Storage

The Coffing TB-602 *toolbox* hoist is the most compact ratchet lever hoist in the market, performs just like the larger models, *plus* comes standard with these great features:

- Plated load chain is standard.
- Weston-type load brake.
- Rubber hand grip for better comfort and security.
- Lightweight design for ease of portability. Use in confined conditions with one-hand operation.
- Forged upper and lower hooks with latches standard.
- Impact resistant, all-steel frame, gear case and cover.
- Hardened link-type steel load chain for strength and long wear.
- Free wheeling feature serves to quickly attach the load.
- Metric rated.

***The
Uses are
Endless***

***Performs Just
Like the Larger
Hoists, but Small
Enough to Fit in
a Hard Hat***



Model TB-602

**550 Lb.
Capacity**

**5 Ft. Lift
Only**

550 Lbs.

S P E C I F I C A T I O N S

Capacity (Lbs.)	Model Number	Product Code	Number of Chainfalls	Chain Dimensions d x t (In.)	Lift w/ One Full Lever Turn (In.)	Handle Pull @ W.L.L. (Lbs.)	Net Weight w/ Standard Lift (Lbs.)
550 Lbs.	TB-602	0210	1	.16 x .47	3.15	56.2	6.0

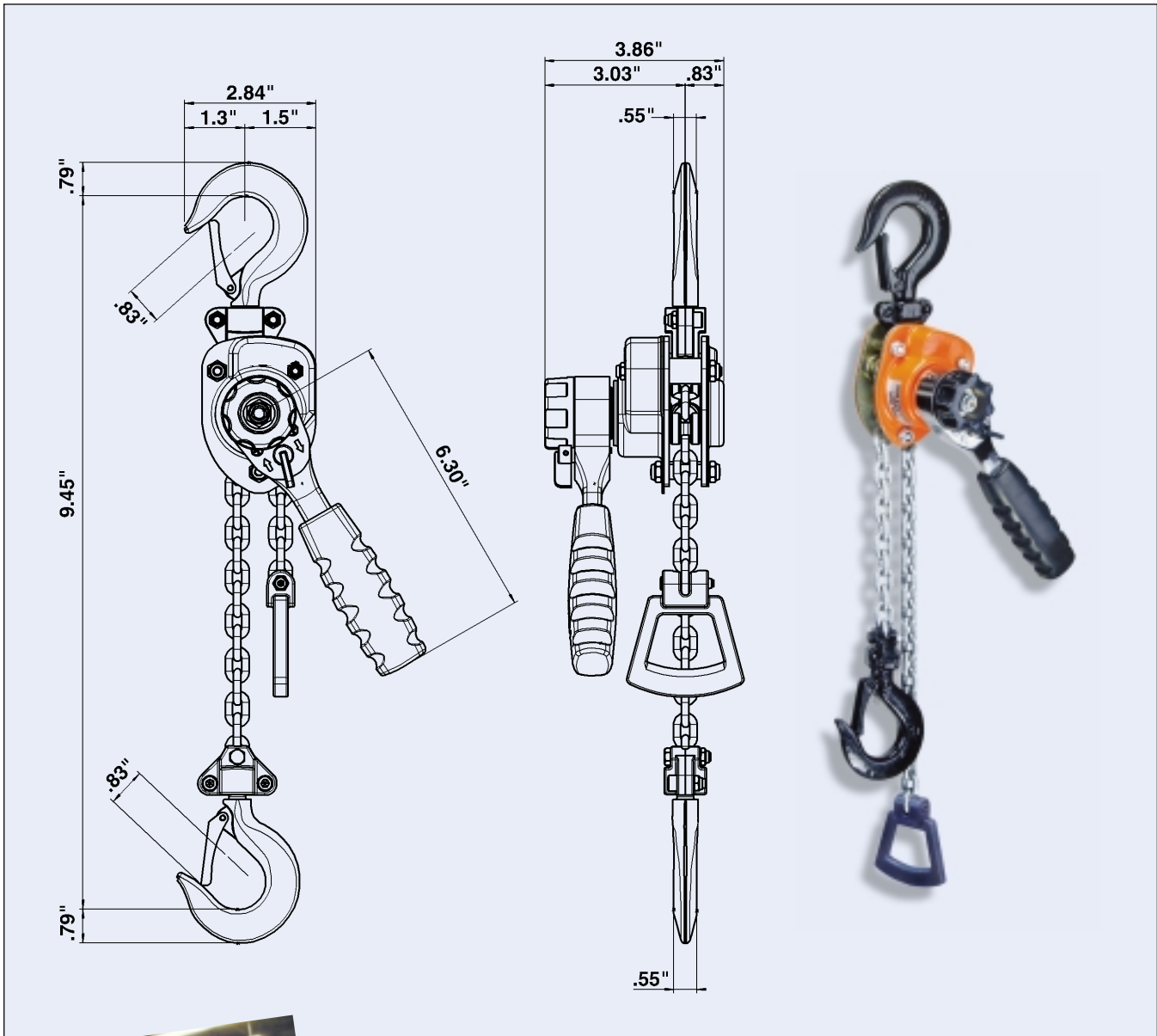

⚠ WARNING

Overloading and Improper Use Can Result In Injury

To Avoid Injury:

- Do not exceed working load limit, load rating, or capacity.
- Do not use to lift people or loads over people.
- Use only alloy chain and attachments for overhead lifting.
- Read and follow all instructions.

High Performance Lifting

COFFING[®]
HOISTS

Country Club Road • PO Box 779
Wadesboro, NC 28170 USA

Phone: (800) 477-5003 (704) 694-2156
FAX: (800) 374-6853 (704) 694-6829

www.coffinghoists.com e-mail: coffing@cmworks.com

Authorized Sales & Service
J. HERBERT CORPORATION
Call 1-800-255-0588
407-846-0588 Fax: 846-1066
info@jherbertcorp.com

Visit us online:
www.jherbertcorp.com