

CB-24

Model SLA

High Performance Lifting

COFFING[®]
HOISTS

Compact, Reliable, Lightweight and Precise — Air Power for Work Stations and Production Lines



The Coffing Model SLA heavy-duty, air chain hoist is lightweight and rugged with compact design—for ease of portability. This powerful and reliable hoist is perfect for most air hoist lifting applications -- work stations and production lines -- *up to 600 lbs.*

CAPACITIES: 250, 300, 500, 600 Lbs.

SPEEDS: **250 & 300 Lb. models**
Under Full Load 31 FPM *Lifting*
 83 FPM *Lowering*

500 & 600 Lb. models
16 FPM *Lifting*
42 FPM *Lowering*

AIR PRESSURE:

Normal operating pressure is 90 PSI

HEADROOM:

10⁷/₈" headroom - 250 & 300 Lb. models

250 - 600 Lb.

Made in USA

- **OVERLOAD PROTECTION** - Standard Protector™ overload device.
- **EXTENDED SERVICE LIFE** - 10-pocket oblique lay liftwheel provides longer chain life.
- **DURABLE EXTERIOR** - Epoxy powder coat finish is smooth and tough.
- **RELIABLE OPERATION** - Double reduction gearing.
- **ON-THE-MONEY** - Variable flow, two lever pendant for precise load spotting.
- **EXHAUST OPTION** - Threaded external exhaust for piping away exhaust in clean room or painting operations.
- **TOUGH AND COMPACT** - Rugged cast aluminum alloy hoist frame. Small, compact design for commercial and industrial applications.
- **AIR POWER** - Industrial-duty air motor for tough applications.
- **LIFETIME LUBE** - Gear train is lifetime-lubricated with non-oxidizing grease.
- **POSITIVE LOAD ENGAGEMENT** - Hardened, forge steel, latch-style lower hook rotates 360°. Upper hook provided with latch for positive load engagement.
- **MADE IN USA**
- **LIFETIME WARRANTY**

DIMENSIONAL DRAWING

Model SLA

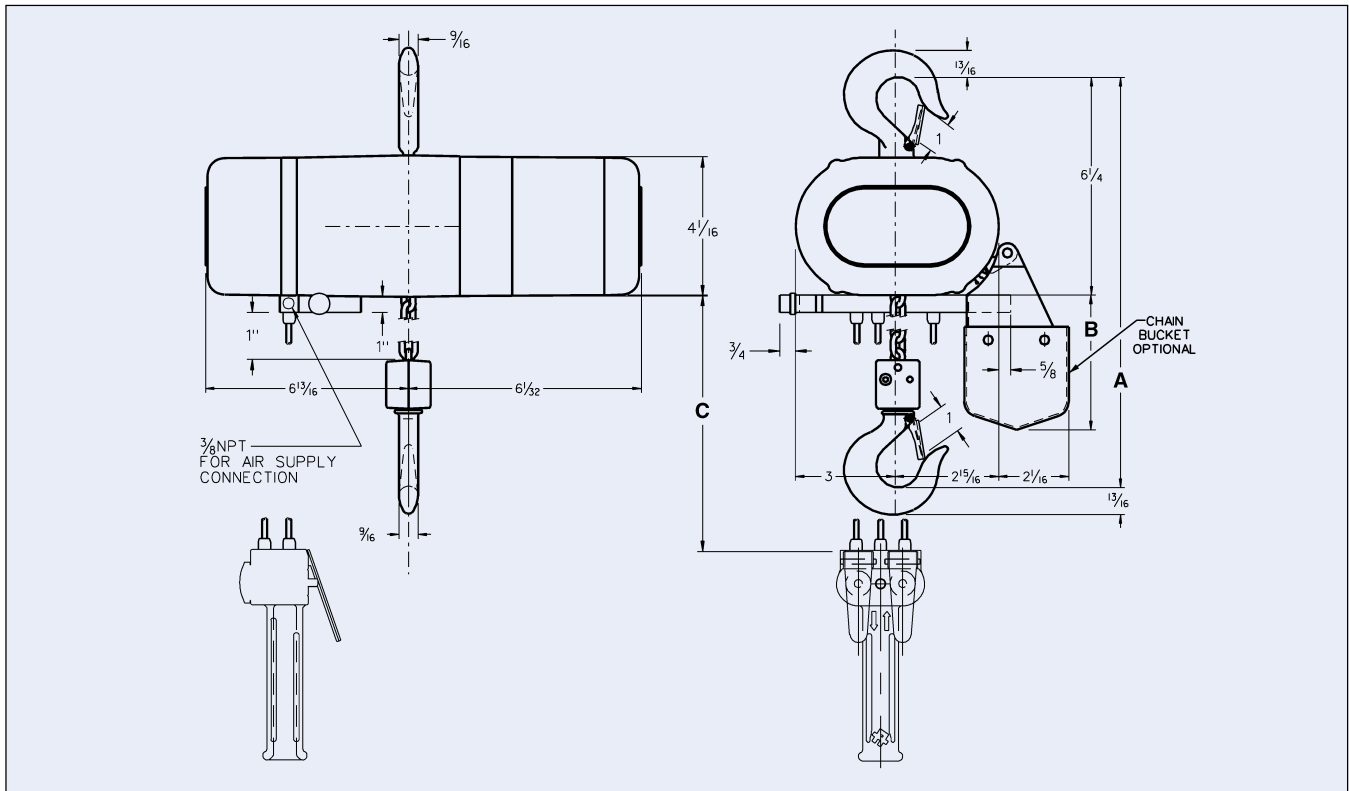

D I M E N S I O N S

All dimensions are in inches unless otherwise indicated.

Model No.	Rated Load (Lbs.)	A	B	* C	No. of Load Chains
SLA0231	250	10 ⁷ / ₈	3 ⁷ / ₈	6' 4"	1
SLA0331	300	10 ⁷ / ₈	3 ⁷ / ₈	6' 4"	1
SLA0516	500	11 ¹⁵ / ₁₆	5 ³ / ₄	6' 4"	2
SLA0616	600	11 ¹⁵ / ₁₆	5 ³ / ₄	6' 4"	2

SHIPPING WEIGHT:

30 Lbs. 250 & 300 Lb. Models
34 Lbs. 500 & 600 Lb. Models

* Pendant drop is for 10' lift. Other lifts available.

Authorized Sales & Service
J. HERBERT CORPORATION
 Call 1-800-255-0588
 407-846-0588 Fax: 846-1066
 info@jherbertcorp.com
 Visit us online:
www.jherbertcorp.com



WARNING

Overloading and Improper Use Can Result In Injury

To Avoid Injury:

- Do not exceed working load limit, load rating, or capacity.
- Do not use to lift people or loads over people.
- Use only alloy chain and attachments for overhead lifting.
- Read and follow all instructions.

High Performance Lifting

COFFING[®]

HOISTS

Country Club Road • PO Box 779
 Wadesboro, NC 28170 USA

Phone: (800) 477-5003 (704) 694-2156
FAX: (800) 374-6853 (704) 694-6829

www.coffinghoists.com • e-mail: coffing@cmworks.com

