

# JDN LOW HEADROOM TROLLEYS

The trolley solution for restricted headroom areas.

Carrying capacities:  
from 0.5 Ton to 6.3 Ton

In areas that are confined to a minimum headroom, we recommend **JDN Low Headroom Trolleys** where the air hoists are horizontally mounted. When only very low headroom is available we recommend the JDN-Ultra-Low Monorail Hoists.

Authorized Sales & Service

**J. HERBERT CORPORATION**

Call 1-800-255-0588

407-846-0588 Fax: 846-1066

info@jherbertcorp.com

Visit us online:

www.jherbertcorp.com

## STANDARD FEATURES

- State of the art by using JDN Air Hoists PROFI TI as well as a new design motor
- Low-maintenance and low-wear operation of the motors by means of a reduction of components
- No additional motor lubrication required
- 2-step travelling speed

## SPECIAL FEATURES

- Able to negotiate curves
- Longer cross beams to improve the minimum headroom even with bulky loads

## OPTIONS

- Rack and pinion drive
- Spark-resistant package
- Offshore paint

## ENERGY FEEDING SYSTEMS

The energy can be fed by various different systems:

- Energy chain
- C-shaped rail
- Square rail
- Spiral hose
- Hose trolleys

## TECHNICAL DATA

Hoist Type Trolley Type		PROFI 05 TI LMF 05-2 t	PROFI 1 TI LMF 05-2 t	PROFI 2 TI LMF 05-2 t	PROFI 3 TI LMF 3.2 t	PROFI 6 TI LMF 6.3 t
Carrying capacity	t	0.5	1	2	3.2	6.3
Number of chain strands		1	1	2	1	2
Motor output Hoist	kW	1	1	1	3.5	3.5
Motor output Trolley	kW	0.2	0.2	0.2	0.2	0.2
Air pressure	PSI Bar	85 6	85 6	85 6	85 6	85 6
Lifting speed at full load	ft/min m/min	32.81 10	16.40 5	8.20 2.5	14.76 4.5	7.21 2.2
Lifting speed without load	ft/min m/min	55.77 17	32.81 10	16.40 5	29.52 9	14.76 4.5
Lowering speed at full load	ft/min m/min	55.77 17	36.09 11	18.04 5.5	35.43 10.8	17.72 5.4
Travelling speed at full load	ft/min m/min	29.53 <sup>1</sup> /45.93 9 <sup>1</sup> /14	29.53 <sup>1</sup> /45.93 9 <sup>1</sup> /14	29.53 <sup>1</sup> /45.93 9 <sup>1</sup> /14	29.53 <sup>1</sup> /45.93 9 <sup>1</sup> /14	29.53 <sup>1</sup> /45.93 9 <sup>1</sup> /14
Air consumption at full load – Lifting	cfm m <sup>3</sup> /min	42.38 1.2	42.38 1.2	42.38 1.2	141.26 4	141.26 4
Air consumption at full load – Lowering	cfm m <sup>3</sup> /min	52.97 1.5	52.97 1.5	52.97 1.5	194.23 5.5	194.23 5.5
Air consumption trolley motor	cfm m <sup>3</sup> /min	21.19 0.6	21.19 0.6	21.19 0.6	21.19 0.6	21.19 0.6
Air connection		G 1/2	G 1/2	G 1/2	G 3/4	G 3/4
Hose dimension (Ø inside)	inch. mm	0.51 13	0.51 13	0.51 13	0.75 19	0.75 19
Weight at standard lift, without control	lbs kg	216.05 98	218.26 99	231.59 105	462.97 210	727.53 330
Chain dimension	inch. mm	0.28 x 0.83 7 x 21	0.28 x 0.83 7 x 21	0.28 x 0.83 7 x 21	0.51 x 1.42 13 x 36	0.51 x 1.42 13 x 36
Weight of chain	lbs/m kg/m	2.20 1	2.20 1	2.20 1	8.38 3.8	8.38 3.8
Standard lift	ft m	9.84 3	9.84 3	9.84 3	9.84 3	9.84 3
Length of control at standard lift	ft m	6.56 2	6.56 2	6.56 2	6.56 2	6.56 2
Max. bottom flange thickness t	inch. mm	0.98 25	0.98 25	0.98 25	1.38 35	1.38 35
Max. bottom flange width b	inch. mm	12.20 310	12.20 310	12.20 310	12.20 310	12.20 310
Min. bottom flange width b	inch. mm	3.15 80	3.15 80	3.15 80	4.92 125	4.92 125

<sup>1</sup> 1st step at F-control with 2-step travelling speed



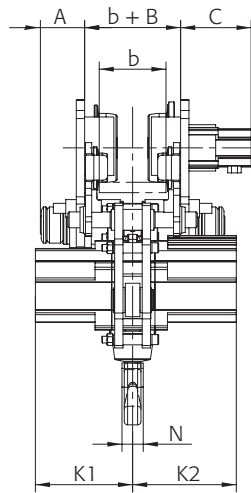
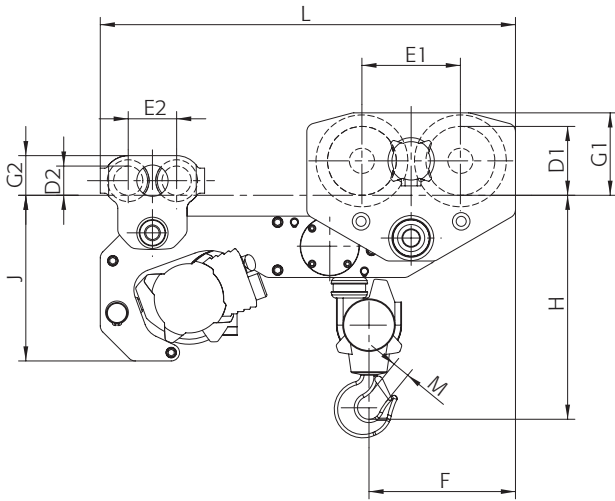

Low Headroom Trolley LMF

**DIMENSIONS**

Hoist Type Trolley Type		PROFI 05 TI LMF 05-2 t	PROFI 1 TI LMF 05-2 t	PROFI 2 TI LMF 05-2 t	PROFI 3 TI LMF 3.2 t	PROFI 6 TI LMF 6.3 t
A max.	inch. mm	4.13 105	4.13 105	4.13 105	4.13 105	4.17 106
B	inch. mm	1.42 36	1.42 36	1.42 36	1.42 36	2.76 70
b min.	inch. mm	3.15 80	3.15 80	3.15 80	3.15 80	4.92 125
C	inch. mm	6.46 164	6.46 164	6.46 164	6.46 164	6.65 169
D1	inch. mm	2.76 70	2.76 70	2.76 70	2.76 70	6.50 165
D2	inch. mm	2.76 70	2.76 70	2.76 70	2.76 70	2.76 70
E1	inch. mm	4.57 116	4.57 116	4.57 116	4.57 116	9.29 236
E2	inch. mm	4.57 116	4.57 116	4.57 116	4.57 116	4.57 116
F	inch. mm	6.77 172	6.77 172	7.68 195	8.98 228	13.82 351
G1	inch. mm	3.74 95	3.74 95	3.74 95	3.74 95	7.76 197
G2	inch. mm	3.74 95	3.74 95	3.74 95	3.74 95	3.74 95
H min.	inch. mm	12.60 320	12.60 320	15.51 394	16.34 415	21.14 537
J	inch. mm	12.60 320	12.60 320	12.60 320	15.63 397	15.63 397
K1	inch. mm	5.71 145	5.71 145	5.71 145	9.17 233	9.17 233
K2	inch. mm	5.98 152	5.98 152	5.98 152	9.76 248	9.76 248
L	inch. mm	28.15 715	28.15 715	28.15 715	32.48 825	39.17 995
M	inch. mm	1.10 28	1.10 28	1.10 28	1.18 30	1.57 40
N	inch. mm	1.65 42	1.65 42	1.65 42	1.65 42	2.01 51
t max.	inch. mm	0.98 25	0.98 25	0.98 25	1.38 35	1.38 35