

Columbus McKinnon Entertainment Division

TM
ShowPro

Operating, Maintenance & Parts Manual

Follow all instructions and warnings for inspecting, maintaining and operating this lifting motor.

The use of any lifting motor presents some risk of personal injury or property damage. That risk is greatly increased if proper instructions and warnings are not followed. Before using this lifting motor, each operator should become thoroughly familiar with all warnings, instructions, and recommendations in this manual. Retain this manual for future reference and use.

Forward this manual to the lifting motor operator. Failure to operate the equipment as directed in the manual may cause injury.



Before using the lifting motor, fill in the information below:

Capacity _____
Serial No. _____
Voltage _____
Purchase Date _____

Capacities

1/2 Ton (454 kg)
1 Ton (907 kg) 2 Ton (1,814 kg)

Authorized Sales & Service
J. HERBERT CORPORATION
Call 1-800-255-0588
407-846-0588 Fax: 846-1066
info@jherbertcorp.com
Visit us online:
www.jherbertcorp.com

LIFETIME WARRANTY

Every Columbus McKinnon hoist is thoroughly inspected and performance tested prior to shipment from the factory. If any properly installed, maintained and operated hoist as outlined in the applicable accompanying hoist manual develops a performance problem due to defective materials or workmanship as verified by Columbus McKinnon Corporation, repair or replacement of the hoist will be made to the original purchaser without charge and the hoist will be returned, transportation prepaid. This warranty does not apply where deterioration is caused by normal wear, abuse, improper or inadequate power supply, improper or inadequate maintenance, eccentric or side

loading, overloading, chemical or abrasive actions, excessive heat, unauthorized modifications or repairs, or use of non-Columbus McKinnon Corporation repair parts. **EXCEPT AS STATED HEREIN, COLUMBUS MCKINNON CORPORATION MAKES NO OTHER WARRANTIES, EXPRESS OR IMPLIED, INCLUDING WARRANTIES OF MERCHANTABILITY AND FITNESS FOR A PARTICULAR PURPOSE.**

WARNING

Alterations or modifications of equipment and use of non-factory repair parts can lead to dangerous operation and injury.

TO AVOID INJURY:

- **Do not alter or modify equipment**
- **Do not use equipment to lift, support or otherwise transport people**
- **Do not suspend unattended loads over people**

COFFING[®] HOISTS

Country Club Road
P.O. Box 779
Wadesboro, North Carolina 28170
Phone (800) 477-5003
Fax (800) 374-6853

CM[®]

140 John James Audubon Parkway
Amherst, New York 14228-1197
Phone (800) 888-0985
Fax (800) 210-9480

SAFETY PRECAUTIONS

Each Lifting Motor is built in accordance with the specifications contained herein and at the time of manufacture complies with our interpretation of applicable sections of *American Society of Mechanical Engineers Code (ASME) B30.16 "Overhead Hoists," the National Electrical Code (ANSI/NFPA 70) and the Occupational Safety and Health Act (OSHA). Since OSHA states the National Electrical Code applies to all electric lifting motors, installers are required to provide current overload protection and grounding on the branch circuit section in keeping with the code. Check each installation for compliance with the application, operation and maintenance sections of these articles.

*Copies of this standard can be obtained from ASME Order Department, 22 Law Drive, Box 2300, Fairfield, NJ 07007-2300, U.S.A.

WARNING

Improper operation of a lifting motor can create a potentially hazardous situation which, if not avoided, could result in death or serious injury. To avoid such a potentially hazardous situation, THE OPERATOR SHALL:

1. **NOT** operate a damaged, malfunctioning or unusually performing lifting motor.
2. **NOT** operate the lifting motor until you have thoroughly read and understood the manufacturer's Operating and Maintenance Instructions or Manuals.
3. **NOT** operate a lifting motor which has been modified without the manufacturer's approval or without certification that it is in conformity with ANSI/ASME B30 volumes.
4. **NOT** lift more than rated load for the lifting motor.
5. **NOT** use lifting motor with twisted, kinked, damaged, or worn load chain.
6. **NOT** use the lifting motor to lift, support, or transport people.
7. **NOT** stand beneath a moving load! Do not move a load in such a manner as to endanger personnel.
8. **NOT** operate a lifting motor unless all persons are and remain clear of the supported load.
9. **NOT** operate unless load is centered under lifting motor.
10. **NOT** attempt to lengthen the load chain or repair damaged load chain.
11. Protect the lifting motor's load chain from weld splatter or other damaging contaminants.
12. **NOT** operate lifting motor when it is restricted from forming a straight line from hook to hook in the direction of loading.
13. **NOT** use load chain as a sling, or wrap chain around load.
14. **NOT** apply the load to the tip of the hook or to the hook latch.
15. **NOT** apply load unless load chain is properly seated in the chain sprocket(s).
16. **NOT** apply load if bearing prevents equal loading on all load supporting chains.
17. **NOT** operate beyond the limits of the load chain travel.
18. **NOT** leave load supported by the lifting motor unattended unless specific precautions have been taken.

19. **NOT** allow the load chain or hook to be used as an electrical or welding ground.
20. **NOT** allow the load chain or hook to be touched by a live welding electrode.
21. **NOT** remove or obscure the warnings on the lifting motor.
22. **NOT** operate a lifting motor on which the safety placards or decals are missing or illegible.
23. **NOT** operate a lifting motor unless it has been securely attached to a suitable support.
24. **NOT** operate a lifting motor unless load slings or other approved single attachments are properly sized and seated in the hook saddle.
25. Take up slack carefully - make sure load is balanced and load holding action is secure before continuing.
26. Shut down a lifting motor that malfunctions or performs unusually and report such malfunction.
28. Warn personnel of an approaching load.

CAUTION

Improper operation of a lifting motor can create a potentially hazardous situation which, if not avoided, could result in minor or moderate injury. To avoid such a potentially hazardous situation, THE OPERATOR SHALL:

1. Maintain firm footing or be otherwise secured when operating the lifting motor.
 2. Check brake function by tensioning the lifting motor prior to each lift operation.
 3. Use hook latches. Latches are to retain slings, chains, etc. under slack conditions only.
 4. Make sure the hook latches are closed and not supporting any parts of the load.
 5. Make sure the load is free to move and will clear all obstructions.
 6. Avoid swinging the load or hook.
 7. Make sure hook travel is in the same direction as shown on the controls.
 8. Inspect the lifting motor regularly, replace damaged or worn parts, and keep appropriate records of maintenance.
 9. Use factory recommended parts when repairing the unit.
 10. Lubricate load chain per lifting motor manufacturer's recommendations.
 11. **NOT** use the lifting motor's overload limiting clutch to measure load.
 12. **NOT** use limit switches as routine operating stops. They are emergency devices only.
 13. **NOT** allow your attention to be diverted from operating the lifting motor.
 14. **NOT** allow the lifting motor to be subjected to sharp contact with other lifting motors, structures, or objects through misuse.
 15. **NOT** adjust or repair the lifting motor unless qualified to perform such adjustments or repairs.
-

TABLE OF CONTENTS

Safety Precautions	2
Lifting Motor Specifications	3
Application Information	3
Safety Information	4
Installation	4
Operation	5
Maintenance	6
Inspection and Maintenance Check List	10
Recommended Lubrication Schedule.....	11
Wiring Diagrams	12
Trouble Shooting	13
Replacement Parts List.....	14
Warranty	Back Cover

LIFTING MOTOR SPECIFICATIONS

The ShowPro is a rugged and portable lifting motor designed for the demands of rigging applications. With its compact construction and ability to operate inverted, the ShowPro allows for greater flexibility in mounting the unit as required by each application. The light weight and high strength of the aluminum alloy housings are a plus when the lifting motor is moved from site to site. The ShowPro's oil filled gearbox provides smooth and reliable operation, while its magnetic disc brake provides the sure stopping and secure holding of loads that is expected in rigging applications. As a standard, all ShowPro hooks are equipped with hook latches.

APPLICATION INFORMATION

The ShowPro is intended for professional use in rigging applications to lift and support material loads within its rated capacity. It is designed as a component to be integrated into a rigging control system. The user is responsible for ensuring the

Table 1 - Lifting Motor Specifications

Model	Capacity (tons)	Lifting Speed (mpm/fpm)	HP	Approximate Motor Amperage** at Full Load				
				208V	230V	380V	415V	460V
SP1003	1/2	4.1 / 16	1/2	2.3	2	1.2	1.1	1
SP2003	1	4.1 / 16	1	3.6	3.2	1.9	1.8	1.6
SP4003	2	2 / 8*	1	3.6	3.2	1.9	1.8	1.6

* SP4003 models are double-reeved, which reduces the speed by half.

adequacy and reliability of the controls used. Columbus McKinnon Entertainment Division can not be held responsible for applications other than those for which the ShowPro is intended. Prior to installation and operation, we caution the user to review his application for abnormal environmental or handling conditions and to observe the applicable recommendations as follows:

ADVERSE ENVIRONMENTAL CONDITIONS

Do not use the lifting motor in areas containing flammable vapors, liquids, gases or any combustible dusts or fibers. Refer to Article 500 of the National Electrical Code. Do not use this lifting motor in highly corrosive, abrasive or wet environments. Do not use this lifting motor in applications involving extended exposure to ambient temperatures below -10°F or above 130°F.

LIFTING OF HAZARDOUS LOADS

This lifting motor is not recommended for use in lifting or transporting hazardous loads or materials which could cause widespread damage if dropped. The lifting of loads which could explode or create chemical or radioactive contamination if dropped requires fail-safe redundant supporting devices which are not incorporated into this lifting motor.

**Lifting motors will experience an initial current surge of up to three times the values listed.

LIFTING OF GUIDED LOADS

This lifting motor is recommended only for lifting freely suspended loads and is not for use in the lifting of guided loads, including dumbwaiters and elevators. Such applications require additional protective devices which are not incorporated into this lifting motor. For such applications, refer to the requirements of applicable state and local codes, and the American National Safety Code for elevators, dumbwaiters, escalators and moving walks (ASME A17.1).

WARNING

Failure to comply with safety precautions outlined throughout this manual can result in serious injuries or death. Before using this lifting motor, each operator should become thoroughly familiar with all warnings, instructions and recommendations in this manual.

SUSPENDING LOADS OVER PEOPLE

The suspension of loads over people demands the highest level of rigging knowledge, equipment, and equipment maintenance. The ShowPro must be installed and used in accordance to rigorous rigging standards required when suspending loads over people. These include the following important precautions.

1. It is preferred that the load always be tied off with auxiliary chains or cables before access to the area beneath the load is permitted. As an alternative, the system may be designed such that malfunction or failure of one hoist's load bearing components does not cause load loss and/or overloading of any other hoists in the system. Note that in such a system, hoist performance and function must be monitored visually or with the use of load cells.
2. Never operate the lifting motor while people are under the load.

SAFETY INFORMATION

1. Follow all local electrical and safety codes, as well as the National Electrical Code (NEC) and the Occupational Safety and Health Act (OSHA) in the United States.
2. The lifting motor must be securely and adequately grounded. The lifting motor control cable includes a green/yellow wire for ground and is equipped with a connecting plug that includes a prong for ground.
3. Be careful when touching the exterior of an operating motor; it may be hot enough to be painful or cause injury. With modern motors this condition is normal if operated at rated load and voltage (modern motors are built to operate at higher temperatures).

WARNING

Always disconnect the power source before working on or near a lifting motor or its connected load. If the power disconnect point is out of sight, lock it in the open position and tag to prevent unexpected application of power.

4. Protect the power cable from coming in contact with sharp objects.
5. Do not kink power cable and never allow the cable to come in contact with oil, grease, hot surfaces, or chemicals.
6. Make certain that the power source conforms to the requirements of your equipment.
7. Inspect the unit daily before operating lifting motor.
8. Cluttered areas and benches invite accidents.
9. The operator should not engage in any practice which will divert his attention while operating the lifting motor.
10. Before using the lifting motor, the operator should be certain that all personnel are clear.
11. Do not operate lifting motor with loads exceeding its rated capacity.
12. Supporting frames or beams used as a lifting motor hanger must have a greater load capacity than the lifting motor.
13. Do not attempt to operate lifting motor beyond normal maximum lift range.

14. Align lifting motor for a straight line pull. Avoid side pull or end pull.
15. Do not operate lifting motor with twisted or damaged chain.
16. Do not operate a damaged or malfunctioning lifting motor until necessary adjustments or repairs have been made.
17. Do not use lifting motor to lift people or to carry loads over people.
18. Do not leave a load suspended in the air unattended.
19. Always remove load before making repairs.
20. Do not remove or obscure capacity or warning decals.

INSTALLATION

CONTROL SYSTEM REQUIREMENTS

The ShowPro must be connected to a control system that is properly designed to operate the lifting motor and to handle the power consumption of the motor. Note the motor amperages listed on page 3. Be aware that the initial current surge when lifting is typically up to three times the steady current. Make certain that the control system is set up to switch power to the lifting motor as described in the wiring diagrams on page 12.

The control cable from the control system will plug into the supplied control pigtail. Ensure that all power conductors are adequate in size to avoid large voltage drops. Control systems and connectors are available through Columbus McKinnon Entertainment Division.

PRELIMINARY CHECKS

Before installing the lifting motor, check the following:

1. After unpacking the unit, carefully inspect for any damage that may have occurred during transit. Check for loose, missing or damaged parts. Shipping damage claims must be filed with the carrier. Be sure that the voltage labeled on the unit matches your power supply.
2. Make sure all supporting structures and attaching devices have the strength to withstand several times the weight of the intended loads. If in doubt, consult a qualified structural engineer.
3. Provide proper branch circuit protection for the lifting motor as required by the prevailing electrical codes in your area.
4. Lifting motors should not experience voltage drops of more than 10% of the supply voltage. It is critical to use adequate sized power cables. On dual voltage lifting motors, the installer must ensure that the terminal block in the lifting motor is correctly wired for the intended voltage (See WIRING, page 8).
5. ALWAYS DISCONNECT LIFTING MOTOR FROM POWER SUPPLY before removing electrical cover or when making any electrical connection in the lifting motor.
6. The user's control board must be grounded in accordance with the electrical codes that are applicable in your area. Connecting cables to lifting motors must include a ground conductor. The ShowPro includes a ground wire (green/yellow) in the connection pigtail, which connects to the large ground prong on the connecting plug.

7. The installation area must provide safe operating conditions for the operator, including sufficient room for the operator and other personnel to stand clear of the load at all times.

INSTALLING THE LIFTING MOTOR

1. Be certain that supporting structures and attachment points have the strength to withstand several times the weight of the intended loads.
2. Hooks should be attached to appropriate points such that the load will be applied at the saddle of the hook only. Never allow a load to rest on the tip of a hook. Hook latches should always close completely.
3. The ShowPro can be mounted upright or upside down.
4. Connect the controls to the lifting motor as shown in the wiring diagrams on page 12. When installing a three-phase lifting motor, check to make sure the lifting motor travels in the direction intended when operating the controls. To correct improper motor travel, reverse any two wires (except the green ground wire) at the power source. Do not change connections in the lifting motor or connecting plug. Once the direction of travel is verified to be correct, permanent connections can be made at the power source.
5. Once the controls are properly connected, run the motor in the down direction to allow enough length of chain to attach the load hook to its suspension point. Once again, you should be certain of the structural strength at the attachment point and ensure that the load will bear on the saddle of the hook. The lifting motor should be permitted to align itself for a straight line pull. Do not attempt to pull around corners.
6. It is imperative that no twists exist in the chain, especially on double-reeved units. **Chain twists can create hazardous conditions!** Twists occur when the 2-ton load block is capsized or when the slack end of chain is not properly attached at the side of the lifting motor.
7. If necessary, lubricate the chain, see LUBRICATION, page 8.

CHAIN BAG (OPTIONAL ACCESSORY)

It is strongly recommended to use a chain bag with the ShowPro. Chain bags similar to the chain bag shown in Figure 1 are available from Columbus McKinnon Entertainment Division. The bags, which are colored black, fit closely to the lifting motor and are as inconspicuous as possible. Be sure to follow the directions that come with ShowPro chain bags before installing.

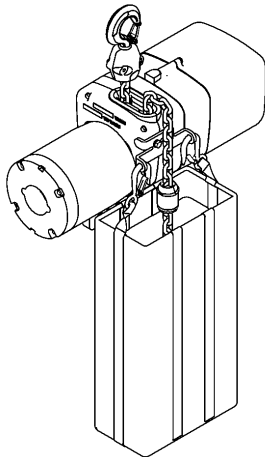

Figure 1 - ShowPro With Optional Chain Bag

CAUTION

Do not attempt to store more chain in a chain bag than outlined on its instruction sheet or serious damage to the lifting motor may result and hazardous conditions may be created.

OPERATION

This lifting motor is designed for operation within the limits of its rated capacity. It is controlled by a user supplied control system that will switch the lifting motor "UP" and "DOWN" according to the wiring diagrams on page 12. The control system must be able to handle the power requirements of the motors that are connected to it.

WARNING

Do not use lifting motor to lift, support or otherwise transport people.

OVERLOAD LIMITING PROTECTION

This lifting motor is equipped with a factory-calibrated overload limiting clutch that will permit the lifting of loads within its rated capacity, but will prevent the lifting of damaging overloads while the lifting motor is being operated. If the load being lifted exceeds the lifting capability of the overload clutch, the motor will continue to run, causing overheating of both the clutch and motor. This condition should be avoided by immediately releasing the "GO" button and reducing the load to within the rated capacity of the lifting motor. See GEARING, page 9, for additional instructions on this device.

CAUTION

The overload limiting clutch is an emergency protective device and should not be used to measure the maximum load to be lifted, or to sense the overload imposed by a constrained load. While the overload limiting clutch will protect the lifting motor from damaging overloads, it will not ensure that a load is within the rated capacity of the lifting motor.

LIMITS OF TRAVEL

The ShowPro's travel is limited by the load block and chain stop. Once one or the other makes contact with the motor housing, the internal overload limiting clutch will slip. **DO NOT** rely on the load block and chain stop to regulate the amount of travel. The operator should be aware of the location of the load at all times. If the extreme limits are encountered, the user should immediately stop the motor.

To synchronize two or more lifting motors, it is preferable to operate individual units to the level of the other lifting motors. The lifting motors should be in full view to prevent the load block or chain stop from contacting the units housing.

WARNING

Do not purposely allow the overload limiting clutch to slip. Excessive slippage will damage the clutch and motor. Hazardous conditions will be created!

OPERATING NOTES

Here are some points which should be observed to maintain proper operation.

1. Do not overload the lifting motor.
2. Do not make extreme side pulls with the lifting motor.
3. **Do not sling the lifting motor load chain around an attachment point. Use a proper sling.**
4. Before raising a load, always check to see that it is held securely in the hook or sling chains, etc. Raise the load only until the load chain is taut and then double check the rigging before continuing to raise the load. Load must be supported in saddle of hook, not by hook tip or hook latch.
5. Do not stand beneath a moving load! Do not move a load in such a manner as to endanger personnel.
6. Do not lower into areas where visibility is obscured unless someone else is guiding the operation.
7. Use common sense at all times when operating a lifting motor.
8. Do not operate if direction of hook travel is not the same as indicated on button being pushed.
9. Do not operate unless hook travel limit devices function. Test without load each shift.
10. Do not operate when lifting motor is not centered over load.
11. Do not operate if chain is not seated properly in sprockets or sheave grooves.
12. Do not operate a damaged or malfunctioning lifting motor.
13. **DO NOT USE LIFTING MOTOR TO LIFT, SUPPORT OR OTHERWISE TRANSPORT PEOPLE.**

MAINTENANCE

INSPECTIONS

A planned inspection routine should be established for this lifting motor based upon frequency of use, severity of use, and environmental conditions. Some inspections should be made frequently (daily to monthly) and others periodically (monthly to yearly). It is strongly recommended that an Inspection and Maintenance Check List and an Inspector's Report, similar to those shown in Figures 7A and 7B, be used and filed for reference. All inspections should be performed or overseen by a designated inspector. Special inspections should be made following any significant repairs or any operating occurrence leading one to suspect that the lifting motor's capability may have been impaired.

LOWERING WITHOUT POWER

If the power fails with a load suspended, the lifting motor will automatically stop. In an emergency the load can be lowered without power as follows:

1. **DISCONNECT LIFTING MOTOR FROM POWER SUPPLY AND REMOVE ELECTRICAL COVER.**



WARNING

Failure to follow proper lockout/tagout procedures may present the danger of electrical shock.

TO AVOID INJURY:

Disconnect power and lockout/tagout disconnecting means before removing cover or servicing this equipment.

WARNING

Do not allow screw driver blades to touch rotating friction disc "C" (See Figure 4, page 8).

2. Open disc brake manually by using two screwdriver blades, one on each side of the brake at a point close to the brake spring posts. Apply pressure to the underside of the armature plate (points "X", Figure 4, page 8) to close the solenoid and release the brake.

CAUTION

Do not allow the load to descend rapidly. This causes the motor to race and serious damage may result.

3. Use several quick releases instead of holding brake open continuously. Do not exceed normal lowering speed.

HOOKS

Refer to Figure 2.

1. Inspect hooks once daily for cracking, extreme wear or spreading. Replace hooks showing any of these signs. If the throat openings are spread wider than the maximum permissible 15% increase listed here, the hooks have been overstressed and must be replaced. Any hook that is bent or twisted more than 10° from the plane of an unbent hook must also be replaced.
2. The hook latches should be inspected to ensure that they close the hook throat opening in a secure manner when a load is applied. Inspect the hook shank and nut for any stripping of the threads or other damage. The hook nut should be fully restrained by the retaining pin.
3. In addition to above, load hooks should be inspected for cracks by the magnetic particle, dye penetrant or other suitable crack testing inspection method. This should be done at least once a year.

Lifting Motor Capacity	"X" Dimension*	
	Top Hook	Bottom Hook
1 Ton & Under	1 ¹¹ / ₃₂ "	1 ⁷ / ₃₂ "
2 ton	1 ¹¹ / ₃₂ "	1 ¹¹ / ₃₂ "

(*) Maximum permissible throat opening of hook.

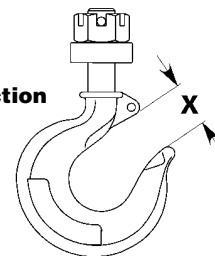

Figure 2 — Hook Inspection

CHAIN

Chain is to be kept clean and lubricated (See LUBRICATION, page 8). Visually check chain every time lifting motor is used. The lifting motor must not be operated when chain is twisted or kinked. An important phase of lifting motor maintenance is chain inspection. Check individual links and check for chain elongation.

1. Check the chain for overall wear or stretch by selecting an unworn, unstretched length of chain (at the slack end for example). Let the chain hang vertically with a light load (about 20 pounds) on the chain to pull it taut. Use a large caliper to measure the outside length of a convenient number of links (about 12"). Measure the same number of links in a used section of chain and calculate the percentage increase in length of the worn chain.
2. If the length of the worn chain is more than 1½% longer than the unused chain (0.015" per inch of chain measured), then the chain should be replaced. If the chain is worn less than 1½%, check it at several more places along its length. If any section is worn more than 1½%, the chain should be replaced.

CAUTION

The chain used on this lifting motor has very carefully controlled dimensions and has been heat treated. Do not attempt to substitute any other manufacturer's chain.

Chain Replacement with Chain in Lifting Motor

1. Suspend the unit by the suspension hook. Run the load hook up close to the bottom of the lifting motor, leaving 3 links between the load block and housing.
2. DISCONNECT LIFTING MOTOR FROM POWER SUPPLY and remove the electrical cover.



WARNING

Failure to follow proper lockout/tagout procedures may present the danger of electrical shock.

TO AVOID INJURY:

Disconnect power and lockout/tagout disconnecting means before removing cover or servicing this equipment.

3. Remove the load block assembly from the old chain. On double-chained lifting motors detach the chain from the chain support and pull it through the load block assembly (See Figure 15).
4. Make a "C" shaped chain link by grinding through the end link on the load end of the old chain.
5. Using the "C" link, attach the new chain to the load end of the old chain. Be sure that the welds of the upstanding links of the new chain will face outward from the load sheave. The end links must be oriented for attachment to the dead-end screw and the chain support (double-chained only) without any twist in the chain.
6. With the electrical cover off, connect the lifting motor to the power supply. Be sure that the green ground wire is properly grounded (See INSTALLATION, page 4).
7. Carefully jog the unit in the up direction and run the joined pieces of chain into the lifting motor until about 15" of the new chain comes out the other side.



WARNING

Failure to follow proper lockout/tagout procedures may present the danger of electrical shock.

TO AVOID INJURY:

Disconnect power and lockout/tagout disconnecting means before removing cover or servicing this equipment.

8. DISCONNECT LIFTING MOTOR FROM POWER SUPPLY.

9. Remove the "C" link and the old chain. Remove the chain stop from the old chain by prying off its retaining ring with a flathead screwdriver. If attached, remove the old chain from the side of the lifting motor by removing the dead-end screw and washers (note placement of washers).
10. Attach the chain stop to the slack end of the new chain by capturing the 12th link with the two stop halves positioned with their tapered ends pointing towards the lifting motor. Slide the sleeve over the halves and attach the retaining ring. If you are not using a chain container, attach the slack end of the new chain to the side of the lifting motor using the dead-end screw and washers. With factory supplied hardware there should be six washers between the lifting motor and chain link and two washers between the chain link and screw head. DO NOT allow twists in the chain.
11. Attach the bottom block on single-chained lifting motors using a new load block screw (See Figure 15). On double-chained lifting motors, feed the chain through the load block (welds of the upstanding links will be in towards the sheave) and fasten the end of the chain to the chain support using a new chain support pin (See Figure 15). Be sure there are no twists in the chain.

Chain Replacement with No Chain in Lifting Motor

Refer to Figure 3.

1. DISCONNECT LIFTING MOTOR FROM POWER SUPPLY and move lifting motor to a work table. Do not remove the electrical cover.



WARNING

Failure to follow proper lockout/tagout procedures may present the danger of electrical shock.

TO AVOID INJURY:

Disconnect power and lockout/tagout disconnecting means before removing cover or servicing this equipment.

2. Lay the lifting motor on its side and remove the four screws that attach the sheave housing to the gear housing (See Figure 10, Ref. No. 2).
3. Carefully pull the sheave housing and motor assembly loose from the gear housing.

CAUTION

There are wires running through the lifting motor. Carefully ease the lifting motor sections apart. Do not jerk them apart.

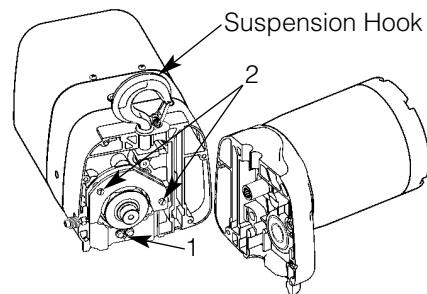

Figure 3 — Chain Replacement with No Chain in Lifting Motor

4. Turn the two lifting motor sections at right angles and remove the chain guide screws on the nearest chain guide (Ref. No. 1, Figure 3).
5. Remove the two chain guide plate screws (Ref. No. 2) and the nearest chain guide plate. Be careful not to lose the two spacers that are between the chain guide plates.
NOTE: Inspect chain guides and load sheave for wear, replace as needed.
6. Lay the new chain over the load sheave. Allow about 15" of chain below the lifting motor on the slack end. Be sure the welds of the upstanding links are out away from the load sheave and that proper orientation is observed for attachment of the dead end. Also be sure the load block (if already attached to the chain) is toward the center of the lifting motor or to your right as you face the load sheave.
7. Replace the chain guide plate and the chain guide. Grease the splined shafts that protrude from both the housing and the motor with NLGI #2 grease.
8. Place the motor coupling on the splined shaft and carefully fit the two lifting motor sections together. Be sure the dead-end nut, the suspension hook and the chain support (double-chained lifting motors only) are all in place. On single-chained lifting motors, the hook shank goes in the center hole; on double-chained lifting motors, it goes in the off-center hole. The suspension hook and load block must be in line. Be careful not to pinch any of the wiring. Turn the lifting motor on its side and replace the four screws and tighten securely.
9. Follow steps 10 and 11 in the previous section, CHAIN REPLACEMENT WITH CHAIN IN LIFTING MOTOR, to complete the chain replacement procedure.

BRAKE

Properly adjusted, this brake will release promptly when energized. It is capable of both smoothly stopping and securely holding the rated capacity of the lifting motor. If the lifting motor develops either undesirable over-travel after the "GO" button is released (this condition is most noticeable in the lowering direction) or hesitates to lift the load promptly when the "GO" button is depressed (this condition is most noticeable in the hoisting direction), the brake should be adjusted.

Brake Adjustment

Refer to Figure 4.

1. DISCONNECT LIFTING MOTOR FROM POWER SUPPLY and remove the electrical cover.

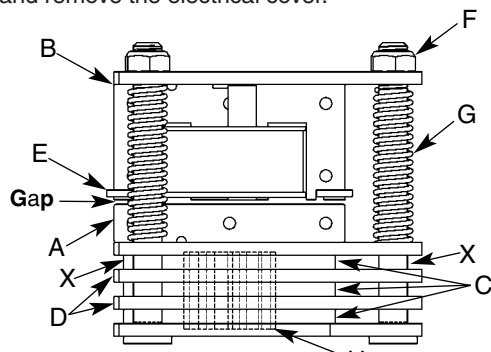

Figure 4 — Brake Assembly

2. With reference to Figure 4, the gap between the brake armature "A" and the field "B" should be checked. The correct gap is 0.015". Adjustment should not be necessary until gap reaches 0.040".
3. Adjust gap by adjusting the 3 locknuts "F" and checking with a feeler gauge to be sure gap is the same on both ends of the solenoid.

CAUTION

Be sure the bottom of the armature does not bear against the splined adapter "H". As adjustments are made, the built-in clearance will be reduced. When this clearance is gone REPLACE BRAKE DISCS. Minimum allowable disc thickness is .162". See Figure 12 for further illustration.

4. Adjustment is now complete and the brake properly set. Replace the electrical cover, reconnect the power supply, and check lifting motor brake action.

WIRING

Refer to Figures 9A and 9B

Single voltage lifting motors which include 208V, 380V and 415V, are equipped with brake coils that are designed for each specific voltage. Dual voltage units can be wired for 230V or 460V. Follow the following steps to convert the voltage of the unit.

1. DISCONNECT LIFTING MOTOR FROM POWER SUPPLY and remove the electrical cover.
2. Dual voltage units have a terminal block for the interconnection of the motor and brake with an outside control system. To convert to the higher or lower voltage, follow the wiring diagrams on page 12. Do not move any wires or make any changes to the electrical circuit except at the terminal block.
3. After converting the voltage, recheck phasing and operation (See INSTALLING LIFTING MOTOR, No. 4, page 5).

IMPORTANT: Always refer to the wiring diagram located on the inside of the electrical cover or Figures 9A and 9B when performing electrical repairs. Make sure all terminals are securely fastened and check for damaged insulation. It is also imperative that the power circuit has conductors of adequate size.

LUBRICATION

Refer to Figure 8.

Proper lubrication is necessary to ensure a long and reliable lifting motor life. Refer to the following and the RECOMMENDED LUBRICATION SCHEDULE for lubrication points, type of lubricant, and frequency of lubrication.

Load Chain

Clean the load chain with acid-free solvent and coat with new SAE 90 gear oil. Wipe excess oil to prevent dripping. Never apply grease to the chain.

Gearing

The gearbox of this lifting motor is filled at assembly with 1½ pints of SAE 90 EP gear oil. To check oil level, hang the unit by the suspension hook (the unit and label will be upside down) and remove the oil level check plug. With the lifting motor hanging level, the gear oil should be even with the hole.

Bearings

All bearings except hook and idler sheave bearings are lubricated at the factory and should not require additional lubrication. Noisy or worn bearings should be replaced.

Hook Bearing

Apply a few drops of new SAE 30 gear or motor oil around the edge of the bearing.

Idler Sheave Bearing (Bushing)

Disassemble load block and apply a light coat of NLGI #2 grease, or equivalent, inside of bearing.

NOTE: If lifting motor is used in an atmosphere containing abrasive dust, frequent cleaning and oiling may be necessary.

LIFTING MOTOR REPAIRS

NOTE: If you do not have an experienced mechanic to do your repair work, we recommend that you send your lifting motor to an approved service station for repairs. Use authorized repair parts only.

⚠ WARNING

Remove load and disconnect lifting motor from power supply before starting to do any repairs or to take any sections apart.

⚠ ⚡ WARNING

Failure to follow proper lockout/tagout procedures may present the danger of electrical shock.

**TO AVOID INJURY:
Disconnect power and lockout/tagout disconnecting means before removing cover or servicing this equipment.**

1. For major repairs or when the lifting motor is to be sectioned in the suspension area, it will be necessary to move the lifting motor to a workbench or table.
2. For repairs which can be done by removing the electrical cover only, the lifting motor need not be moved. Lowering the lifting motor to a convenient working level is desirable.

The following repair instructions will help you in understanding repair procedures, when related to the Replacement Parts List starting on page 14. For clarity these are broken down into areas.

Electrical Parts and Brake

Refer to Figures 9A and 9B.

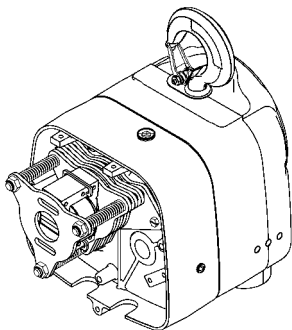

Figure 5 - Electrical Panel Removed

1. Remove the electrical cover. The brake and terminal block are under the cover. The terminal block is now accessible without further disassembly.
2. Remove the electrical panel by removing the three stand-off screws (See Figure 13). Figure 5 shows this area with the panel removed.
3. With the electrical panel taken off, the brake is exposed.
4. Refer to Figure 12 to disassemble the brake. See BRAKE ADJUSTMENT in Maintenance section for brake adjustment.
5. Also refer to the wiring diagram inside the electrical cover or Figures 9A and 9B for wiring instructions.

Motor

Refer to Figures 10 and 11.

The motor is connected to the terminal block with electrical leads running through the housing.

1. If it is necessary to replace or repair the motor, **DISCONNECT THE LIFTING MOTOR FROM THE POWER SUPPLY** and remove the electrical cover.

⚠ ⚡ WARNING

Failure to follow proper lockout/tagout procedures may present the danger of electrical shock.

**TO AVOID INJURY:
Disconnect power and lockout/tagout disconnecting means before removing cover or servicing this equipment.**

2. Remove the cable clamp from the electrical panel and all the terminals leading from the motor to the electrical section (See Figure 13).
3. Remove the four motor mounting bolts attaching the motor to the housing. It will come loose at the motor coupling.
4. Inspect the motor coupling, motor shaft and all the bearings. Replace as necessary.
5. Install new or repaired motor according to the wiring diagram located inside the electrical cover or Figures 9A and 9B.

Gearing

Use the Replacement Parts List for Basic Lifting Motor and Gearbox Parts to help in repairs on gearing (See Figures 10 and 14). As disassembly is extensive for gearing, disconnect the lifting motor and move it to a workbench.

1. Remove electrical cover.
2. Remove electrical panel.
3. Remove brake assembly.
4. Drain oil from the gearbox.
5. Remove the four screws attaching the gearbox cover to the gear housing and remove the gearbox cover.

⚠ CAUTION

Do not disassemble or readjust clutch, or interchange with a clutch assembly from another lifting motor. Doing so will void the warranty and may create an unsafe condition. If replacement is needed due to wear or loss of adjustment, always use a new clutch assembly.

6. Inspect gears for broken or severely worn teeth and inspect all bearings. Replace as necessary. The overload slip clutch is factory calibrated and must not be disassembled or readjusted.
7. Reassemble in reverse order of disassembly making sure the gasket is in place and in good condition. Coat gasket with Permatex® or other gasket cement. Extreme care should be taken to avoid damage to oil seals.

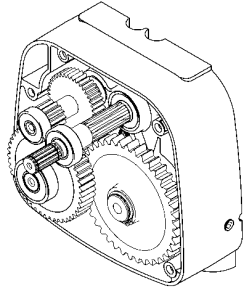

Figure 6 - Assembled Gearing

8. Check all wire terminals to be sure they are properly seated and in accordance with wiring diagram. Before placing lifting motor back into service, check brake adjustment.

Suspension

Use the Parts List for Basic Lifting Motor and Chaining Parts to help in repairs in this section (See Figures 10 and 15). The lifting motor sections must be separated at the top hook line in order to inspect the load sheave and chain guides. See CHAIN REPLACEMENT WITH NO CHAIN IN LIFTING MOTOR, page 7.

While this section is apart, check the following:

- Load sheave
- Chain, Chain guides and plates
- Chain support (on 2 ton models)
- Bearings

Replace parts as necessary including screws, lockwashers, etc. When reassembled, recheck operation.

**INSPECTION AND MAINTENANCE CHECK LIST
ELECTRIC POWERED OVERHEAD CHAIN LIFTING MOTOR**

Type of Lifting Motor _____ Capacity (Tons) _____
 Location _____ Original Installation Date _____
 Manufacturer _____ Manufacturer's Serial No. _____

Item	Frequency of Inspection			Possible Deficiencies	OK	Action Required
	Frequent		Periodic			
	Daily	Monthly				
Operating Controls	*	*	*	Any deficiency causing improper operation		
Brake Mechanism	*	*	*	1. Slippage or excessive drift 2. Glazing, contamination or excessive wear		
Hooks	*	*	*	Excessive throat opening 15%, bent or twisted more than 10°, damaged hook latch, wear, chemical damage, worn hook bearing. To find cracks, (use dye penetrant, magnetic or other suitable detection methods)		
Chain	*	*	*	Inadequate lubrication, excessive wear or stretch, cracked, damaged or twisted links, corrosion or foreign substance		
Hook Connections			*	Cracks, bending, stripped threads		
Pins, Bearings, Bushings Shafts, Couplings			*	Excessive wear, corrosion, cracks, distortion		
Nuts, Bolts, Rivets			*	Looseness, stripped and damaged threads, corrosion		
Sheaves			*	Distortion, cracks, and excessive wear. Build-up of foreign substances		
Housings, Load Block			*	Cracks, distortion. Excessive wear, internal build-up of foreign substances		
Wiring and Terminals			*	Fraying, defective insulation		
Supporting Structure and Attaching Hardware			*	Damage or wear which restricts ability to support imposed loads		
Nameplates, Decals, Warning Labels			*	Missing, damaged or illegible		

NOTE: Refer to the Maintenance Section for further details.

FREQUENCY OF INSPECTION

Frequent — Indicates items requiring inspection daily to monthly. Daily inspections may be performed by the operator if properly designated.

Periodic — Indicates items requiring inspection monthly to yearly. Inspections to be performed by or under the direction of a properly designated period. The exact period of inspection will depend on frequency and type of usage. Determination of this period will be based on the user's experience. It is recommended that the user begin with a monthly inspection and extend the periods to quarterly, semi-annually or annually based on user's monthly experience.

Figure 7A — Recommended Inspection and Maintenance Check List

NOTE: This inspection and maintenance check list is in accordance with our interpretation of the requirements of the Safety Standard for Overhead Hoists ASME B30.16. It is, however, the ultimate responsibility of the employer/user to interpret and adhere to the applicable requirements of this safety standard and to any applicable standards for rigging applications and the suspension of loads over people.

INSPECTOR'S REPORT			
ITEM	REMARKS (LIST DEFICIENCIES AND RECOMMENDED ACTION)		
Inspector's Signature	Date Inspected	Approved by	Date

Figure 7B — Recommended Inspector's Report

RECOMMENDED LUBRICATION SCHEDULE*					
LIFTING MOTOR					
FIGURE & REFERENCE NO.	COMPONENT	TYPE OF LUBRICANT (USE ONLY NEW LUBRICANT)	TYPE OF SERVICE AND FREQUENCY OF LUBRICATION		
			HEAVY	NORMAL	INFREQUENT
Figure 15 Ref. No. 17	Load Chain	SAE 90 gear oil	Daily	Weekly	Monthly
Figure 14	Gearing	SAE 90 extreme pressure gear oil	At periodic inspection (See Figure 7A)		
Figure 15 Ref. No. 33, 45	Load Hook Bearing	SAE 30 gear or motor oil	Weekly	Monthly	Yearly
Figure 15 Ref. No. 39	Idler Sheave Bearing (Bushing) Assembly	NLGI #2 multi-purpose lithium base grease	At periodic inspection (See Figure 7A)		

NOTE: All bearings except hook and idler sheave bearings are prelubricated and sealed.

(*) This lubrication schedule is based on a lifting motor operating in normal environment conditions. Lifting motors operating in adverse atmospheres containing excessive heat, corrosive fumes or vapors, abrasive dust, etc., should be lubricated more frequently.

Figure 8 — Recommended Lubrication Schedule

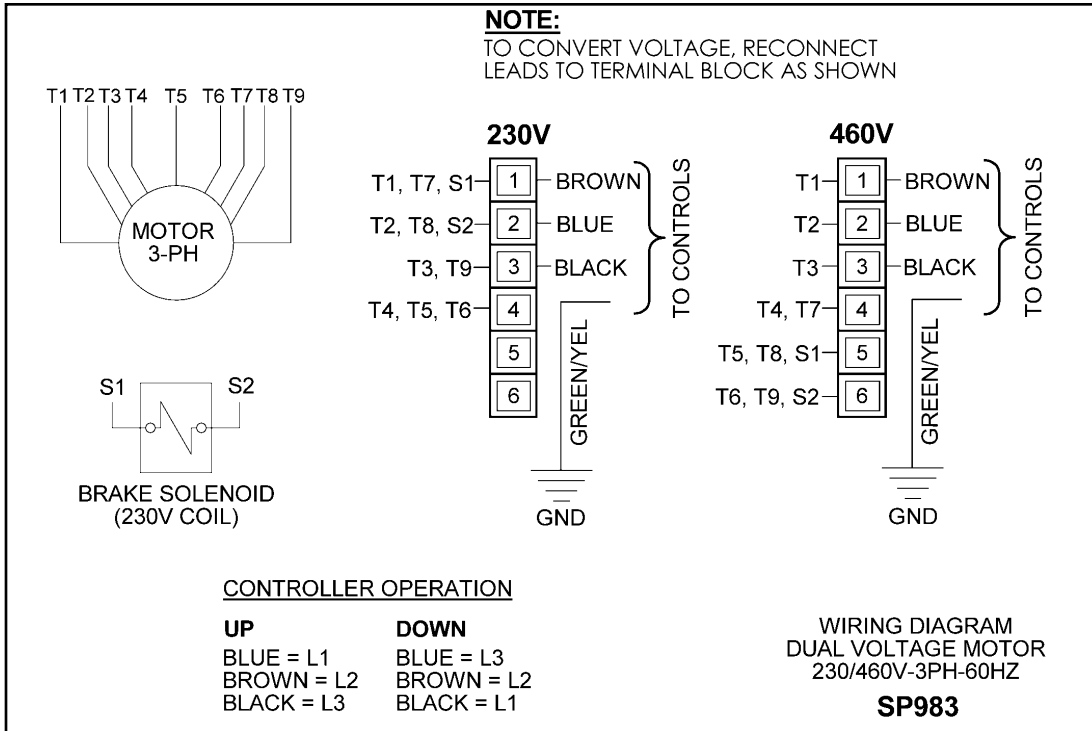

Figure 9A — Wiring Diagram

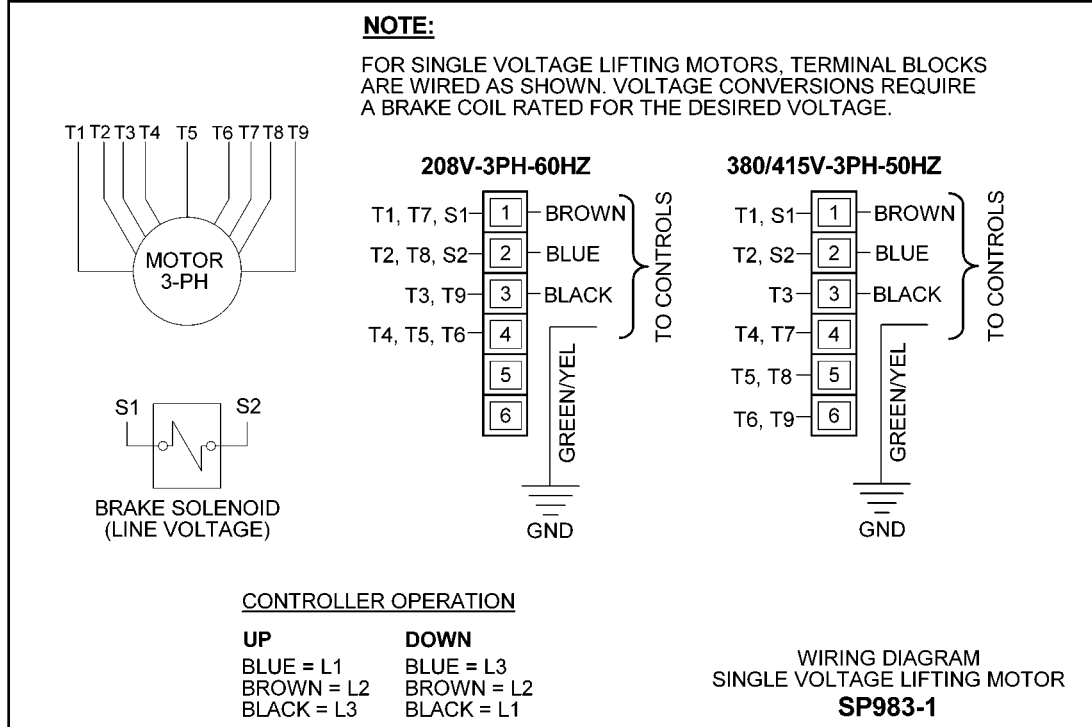

Figure 9B — Wiring Diagram

TROUBLE SHOOTING

Always disconnect unit from the power supply system before removing lifting motor covers or the back cover of control station.



WARNING

Failure to follow proper lockout/tagout procedures may present the danger of electrical shock.

**TO AVOID INJURY:
Disconnect power and lockout/tagout disconnecting means before removing cover or servicing this equipment.**

— Probable Cause —

— Remedy —

Probable Cause	Remedy
Lifting motor does not respond to control station	
<ol style="list-style-type: none"> Power failure in supply lines Wrong voltage or frequency Improper connections in lifting motor or control station Brake does not release Faulty lifting motor reversing contactor 	<ol style="list-style-type: none"> Check circuit breakers, switches and connections in power supply lines. Check voltage and frequency of power supply against the rating on the nameplate of the motor. Check all connections at line connectors and on terminal block. Check terminal block on dual voltage lifting motors for proper voltage connections. Check connections to the solenoid coil. Check for open or short circuit. Check for proper adjustment (See BRAKE ADJUSTMENT, page 8). Check coils for open or short circuit. Check all connections in control circuit. Check for burned contacts. Replace as needed.
Lifting motor does not stop promptly	
<ol style="list-style-type: none"> Lifting motor overloaded Brake not holding 	<ol style="list-style-type: none"> Reduce load to within rated capacity of lifting motor. Check brake adjustment (See BRAKE ADJUSTMENT, page 8). It may be necessary to replace discs.
Lifting motor moves in wrong direction	
<ol style="list-style-type: none"> Three phase reversal Improper connections 	<ol style="list-style-type: none"> Reverse any two wires (except the green ground wire) at the power source (See INSTALLING THE LIFTING MOTOR, No.4, page 5). Check all connections against wiring diagram.
Lifting motor hesitates to lift when energized	
<ol style="list-style-type: none"> Lifting motor overloaded Motor brake requires adjustment Worn overload limiting clutch Low voltage 	<ol style="list-style-type: none"> Reduce load within rated capacity of lifting motor. Check motor brake adjustment (See BRAKE ADJUSTMENT, page 8). Replace clutch. Determine cause of low voltage and bring up to within plus or minus 10% of the voltage specified on the motor. Measure voltage at the lifting motor reversing contactor while lifting a load.
Lifting motor raises but will not lower	
<ol style="list-style-type: none"> "DOWN" circuit open Broken conductor in control cable Faulty lifting motor reversing contactor 	<ol style="list-style-type: none"> Check circuit for loose connections. Check each conductor in the cable. If one is broken, replace entire cable. Check for open or short circuit. Check all connections in control circuit. Replace as needed.
Lifting motor lowers but will not raise	
<ol style="list-style-type: none"> Lifting motor overloaded Low voltage "UP" circuit open Broken conductor in control cable Faulty lifting motor reversing contactor Worn overload limiting clutch 	<ol style="list-style-type: none"> Reduce load to within rated capacity of lifting motor. Determine cause of low voltage and bring up to within plus or minus 10% of the voltage specified on the motor. Measure voltage at the lifting motor reversing contactor while lifting a load. Check circuit for loose connections. Check each conductor in the cable. If one is broken, replace entire cable. Check for open or short circuit, check all connections in control circuit. Check for burned contacts. Replace as needed. Replace overload clutch assembly.
Motor overheats	
<ol style="list-style-type: none"> Excessive load Low voltage Extreme external heating Frequent starting or reversing Brake dragging 	<ol style="list-style-type: none"> Reduce load to within rated capacity of lifting motor. Determine cause of low voltage and bring up to within plus or minus 10% of the voltage specified on the motor. Measure voltage at the lifting motor reversing contactor while lifting a load. As the ambient temperature rises towards the 130°F limitation of the unit, frequency of the lifting motor operation must be limited to avoid overheating of the motor. See ADVERSE ENVIRONMENTAL CONDITIONS, page 3. Excessive inching, jogging or reversing should be avoided since this type of operation will drastically shorten the life of motor, and brake. Check brake adjustment (See BRAKE ADJUSTMENT, page 8).
Lack of proper lifting speed	
<ol style="list-style-type: none"> Lifting motor overloaded Brake dragging Low voltage Overload limiting clutch intermittently slipping 	<ol style="list-style-type: none"> Reduce load to within rated capacity of lifting motor. Check for proper brake adjustment or other defects. Ensure that the voltage at the reversing contactor is within $\pm 10\%$ of the nominal voltage while lifting a load. Replace overload clutch assembly.
Motor brake noise or chatter (while starting lifting motor)	
<ol style="list-style-type: none"> Brake needs adjustment Low voltage 	<ol style="list-style-type: none"> See BRAKE ADJUSTMENT, page 8. Ensure that the voltage at the reversing contactor is within $\pm 10\%$ of the nominal voltage while lifting a load.
Motor brake "buzz" (anytime lifting motor is running)	
<ol style="list-style-type: none"> Brake needs adjustment Broken shading coil on brake frame 	<ol style="list-style-type: none"> See BRAKE ADJUSTMENT, page 8. Replace shading coil or complete brake frame assembly.

Figure 10 - Basic Unit

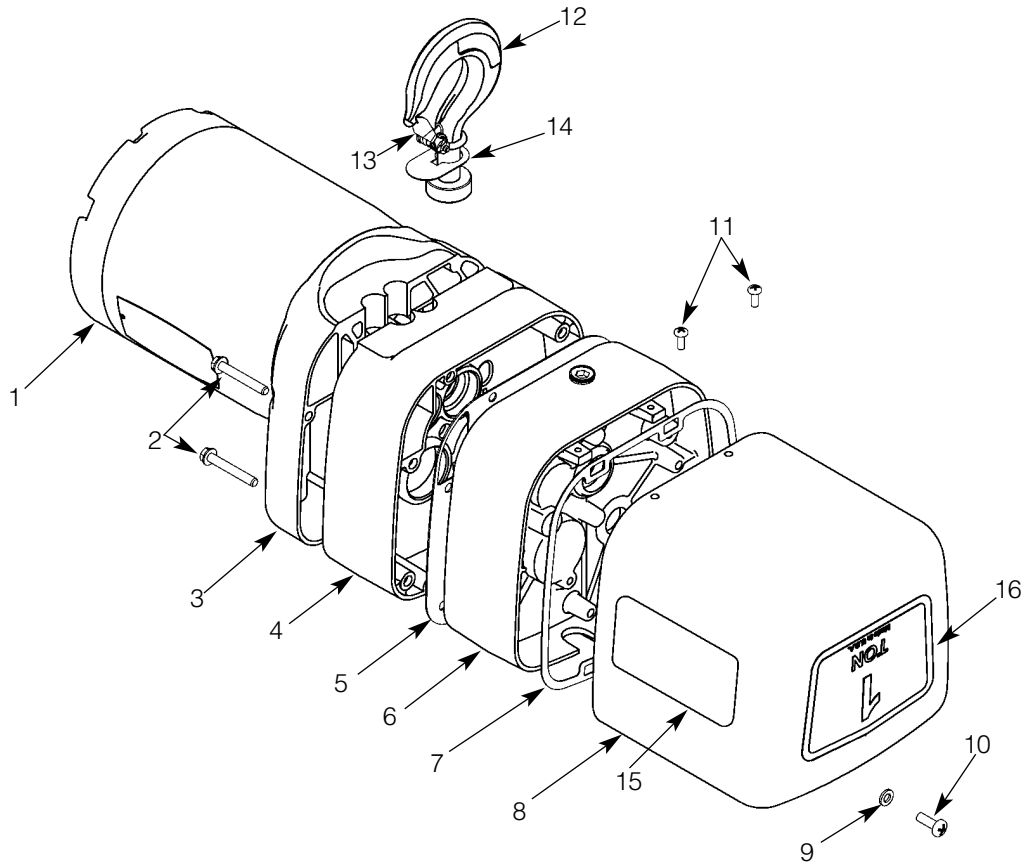

Parts List for Basic Unit

Ref No.	Description	Part No.	Qty	Ref No.	Description	Part No.	Qty
1	Motor (See Figure 11)	—	1	12	Suspension Hook w/Latch Swivel	3M205A01S	1
2	Sheave Housing Screw	H2978P	4	13	Latch Kit Assembly	4X1305	1
3	Sheave Housing	JL39	1	14	Hook Hole Cover	JF277-1	1
4	Gear Housing	JL44	1	15	ShowPro Decal	SP677	2
5	Gearbox Gasket	JL560	1	16	Capacity Decal		
6	Gearbox Cover	JL34	1		1/2 Ton	SP675-1	1
7	Electrical Cover Gasket	JL563	1		1 Ton	SP675-2	1
8	Electrical Cover	JF36-6	1		2 Ton	SP675-3	1
9	1/4" Spring Lockwasher	H4062P	1				
10	1/4 - 20UNC X 3/4" Screw	H1106P	1				
11	10 - 24UNC X 1/2" Screw	H2970	2				

Figure 11 - Motor, 3-Phase

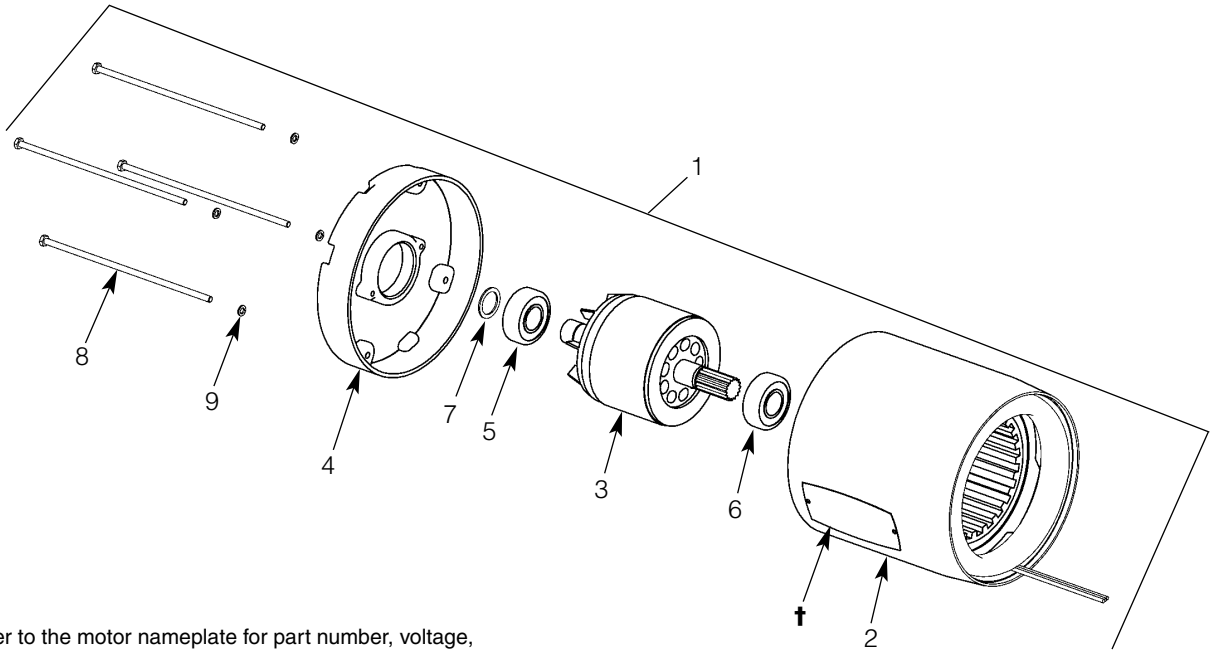

† Refer to the motor nameplate for part number, voltage, full load amperage, horsepower, and other motor information.

Parts List for Motor, 3-Phase

Ref. No.	Description	Part No.	Qty
1	Motor (Complete)		
	1/2 hp	JL863-2	1
	1 hp	JL863-4	1
2	Stator Assembly	*	1
3	Rotor Assembly	*	1
4	End Shield	JL021209-20	1
5	Rear Bearing	500K3	1
6	Front Bearing	732012C	1
7	Shim washer	JL4301-01	1
8	Thru Bolt		
	1/2 hp	JL003801-62	4
	1 hp	JL003801-35	4
9	#10 Spring Lockwasher	H4082P	4

* Not available as an individual part.

Figure 12 - Brake & Solenoid Parts

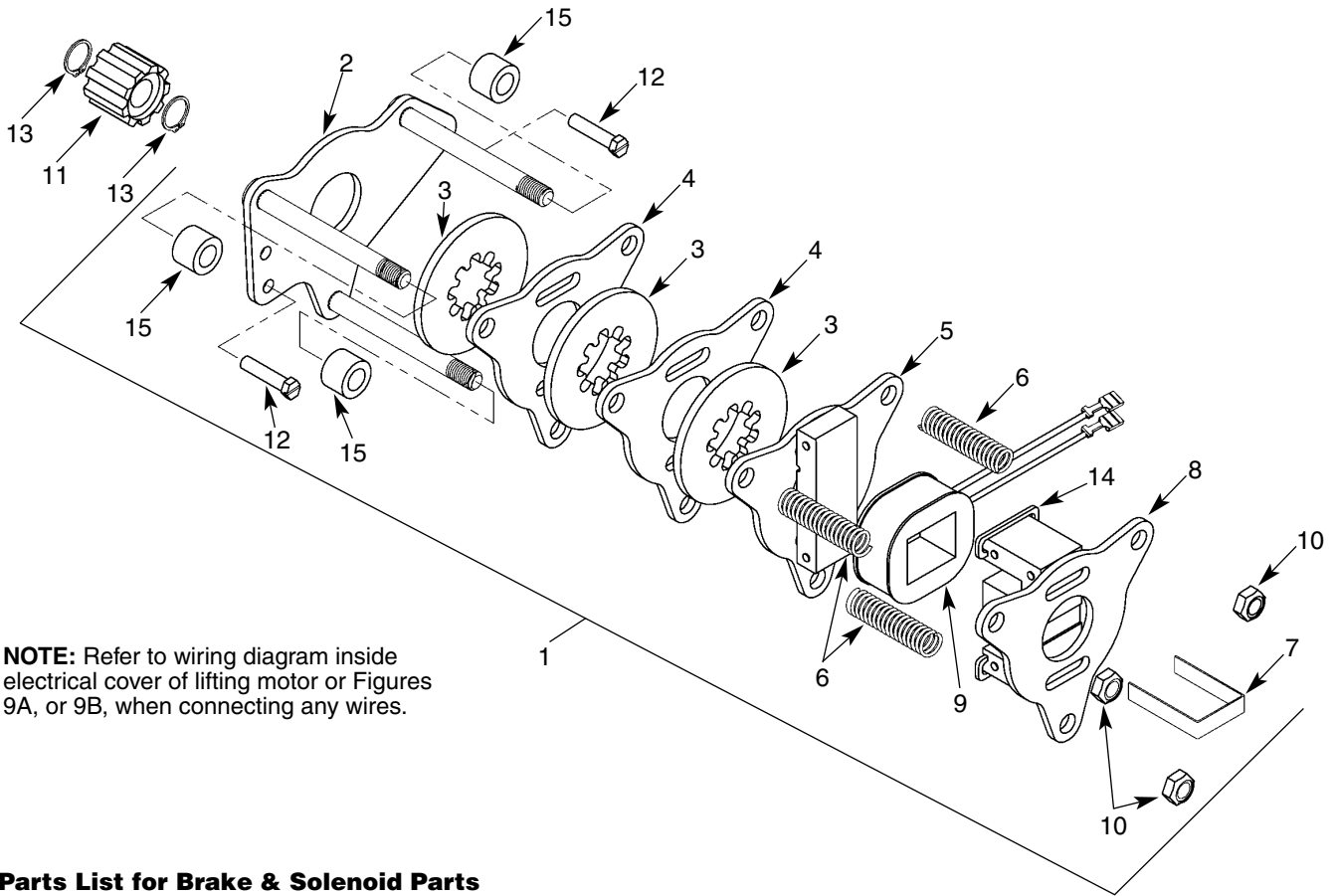

NOTE: Refer to wiring diagram inside electrical cover of lifting motor or Figures 9A, or 9B, when connecting any wires.

Parts List for Brake & Solenoid Parts

Ref No.	Description	Part No.	Qty	Ref No.	Description	Part No.	Qty
1	Disc Brake Assembly			6	Spring	344J6	3
	1/2 hp, 230/460V	JL854-2	1	7	Retainer	JF710	1
	1/2 hp, 208V	JL854-5	1	8	Plate & Frame Assembly	JF857	1
	1/2 hp, 380V	JL854-12	1	9	Brake Coil		
	1/2 hp, 415V	JL854-15	1		230/460V	JF853-2	1
	1 hp, 230/460V	JF854-2C	1		208V	JF853-5	1
	1 hp, 208V	JF854-5C	1		380V	JF853-6	1
	1 hp, 380V	JL854-13	1		415V	JF853-7	1
	1 hp, 415V	JL854-16	1	10	Locknut	H3978	3
2	Plate & Stud Assembly	JF859A	1	11	Adapter	JL142	1
3	Brake Disc			12	Screw	H2976P	2
	1/2 hp	581J1A	2	13	Retaining Ring	H5501	2
	1 hp	581J1A	3	14	Shading Coil	860J1	2
4	Brake Plate for 1/2 hp & 1hp	JF291	2		Shading Coil Adhesive	H7812	1
5	Plate & Armature Assembly	JF858	1	15	Spacer for 1/2 hp	141J2	3

Figure 13 - Electrical Connection Area

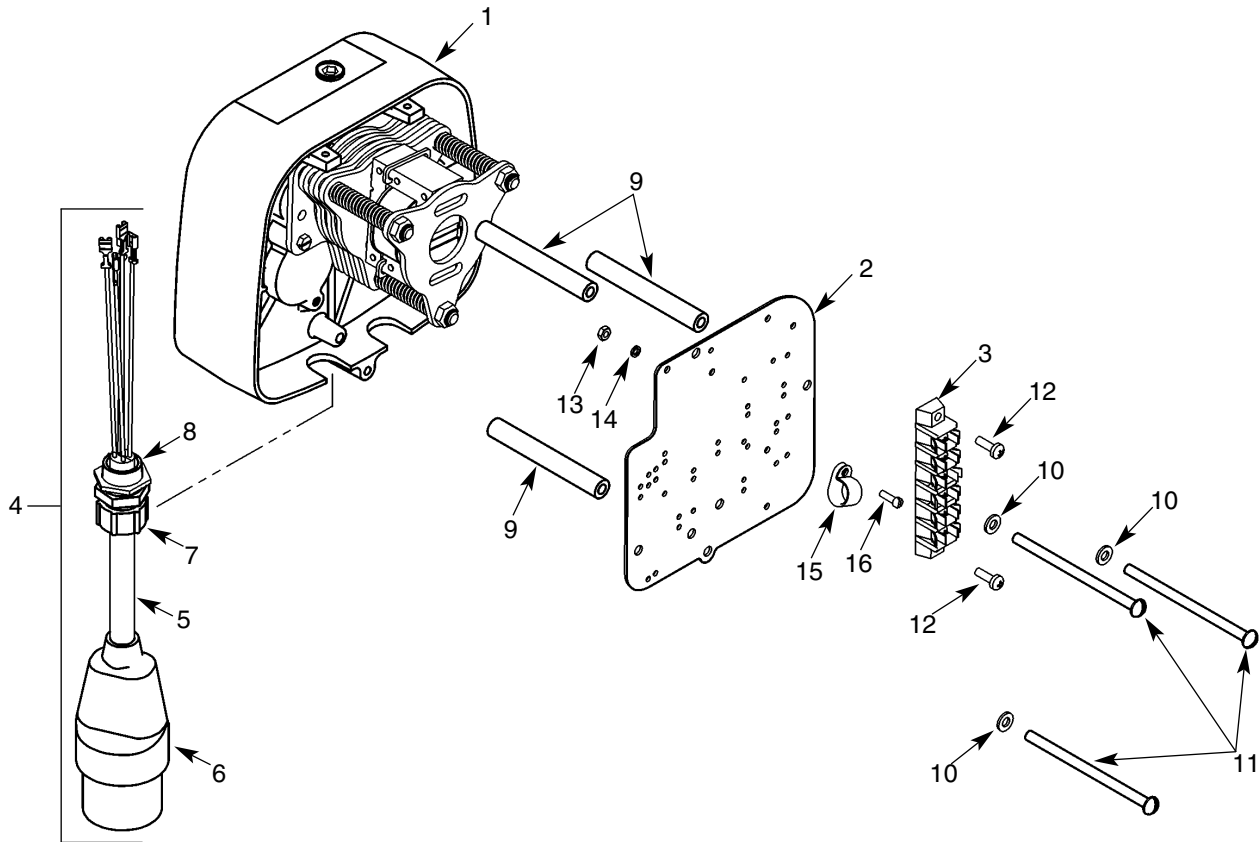

Parts List for Electrical Connection Area

Ref. No.	Description	Part No.	Qty
1	Gearbox Cover	JL34	1
2	Panel Plate	JL257A	1
3	Terminal Block	909K6	1
4	Pigtail, 3-Phase (4 Cond.)	SP955	1
5	SO Cable, Harmonized, 4 Cond., 16AWG	89045	1
6	IEC Male Plug	SP851-1	1
7	Cable Connector	H7530	1
8	Locknut	H7569	1
9	Panel Standoff	JL110	3
10	1/4" Internal-Tooth Lockwasher	H4134	3
11	1/4-20UNC X 4¼" Screw	H1026P	3
12	10-32UNF X 5/8" Screw	H2944	2
13	8-32UNC Hex Nut	H3861P	1
14	#8 Spring Lockwasher	H4081P	1
15	Cable Clamp	H6503	1
16	8-32UNC X 1/2" Screw	H1403P	1

Figure 14 - Gearbox

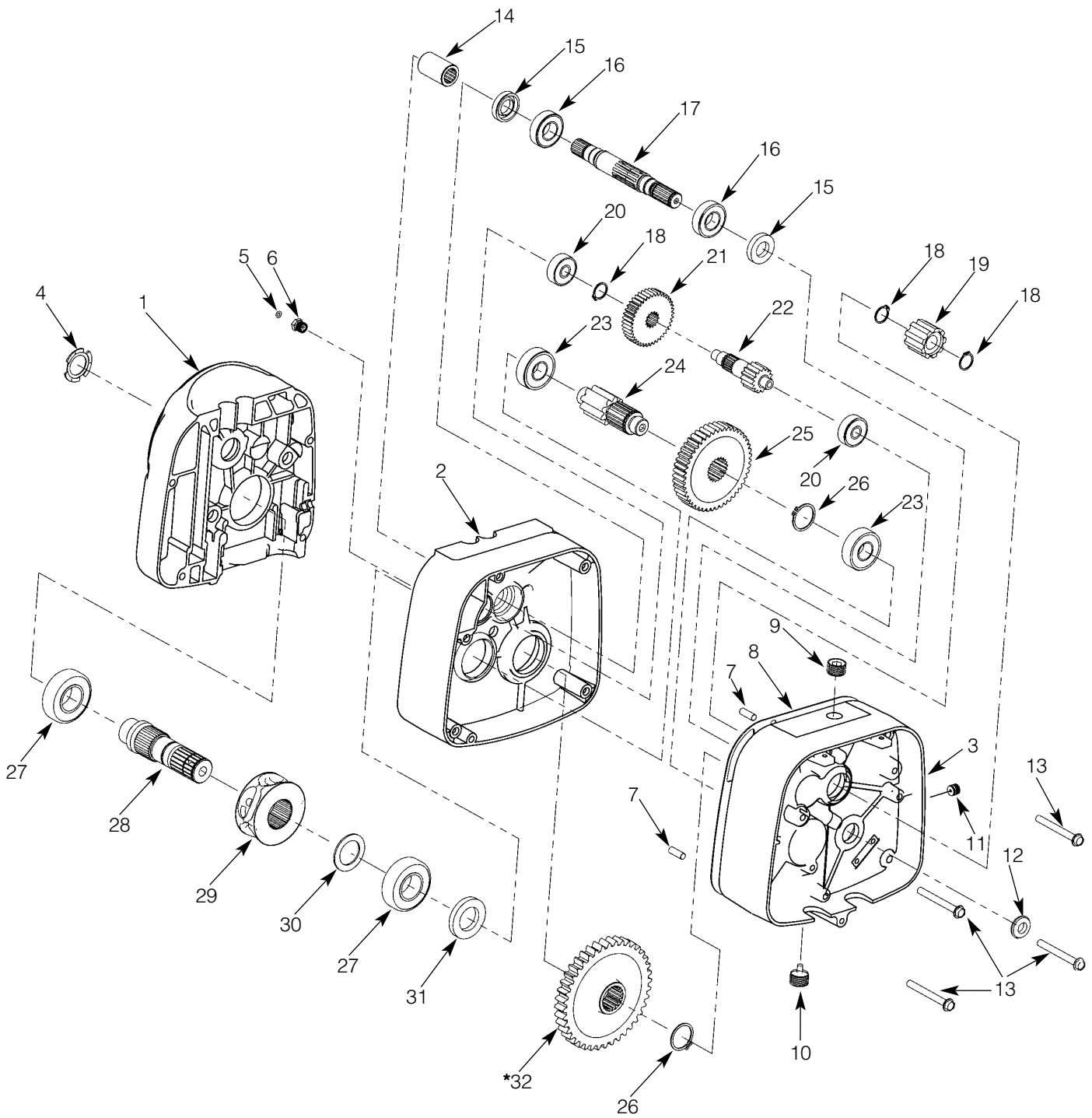

***NOTE: Orient output gear (32) with long boss towards gearbox cover (3).**

Parts List for Gearbox

Ref. No.	Description	Part No.	Qty
1	Sheave Housing	JL39	1
2	Gear Housing (Includes oil seals)	JL44	1
3	Gearbox Cover (Includes oil seals)	JL34	1
4	Spring Washer	360J1	1
5	O-Ring	H5605	1
6	Pressure Relief Fitting	SK1912-21W	1
7	Dowel Pin	H5382	2
8	Gearbox Gasket	JL560	1
9	Oil Fill Plug	H6268	1
10	Oil Drain Plug	H6268	1
11	Oil Level Check Plug	S25-13	1
12	Oil Seal	JL561	1
13	Screw	H2978P	4
14	Motor Coupling	JL107	1
15	Oil Seal	561K2	2
16	Bearing	500K33	2
17	Input Pinion	JL400-1	1
18	Retaining Ring	H5501	3
19	Brake Adapter	JL142	1
20	Bearing	500K34	2
21	High Speed Gear	JL426	1
22	Intermediate Pinion	JL403A	1
23	Bearing	500K36	2
24	Output Pinion	JL401	1
25	Overload Clutch Assembly		
	1/2 Ton	591JG20	1
	1 & 2 Ton	591JG17	1
26	Retaining Ring	H5503	2
27	Bearing	JF504-2	2
28	Load Sheave Shaft Assembly (See Figure 15)	—	1
29	Load Sheave (See Figure 15)	—	1
30	Spacer (See Figure 15)	—	1
31	Oil Seal	561K20	1
32	Output Gear	JL421	1
*	SAE 90 EP Gear Oil		1½ pt

* Not Shown

Figure 15 - Chaining Parts

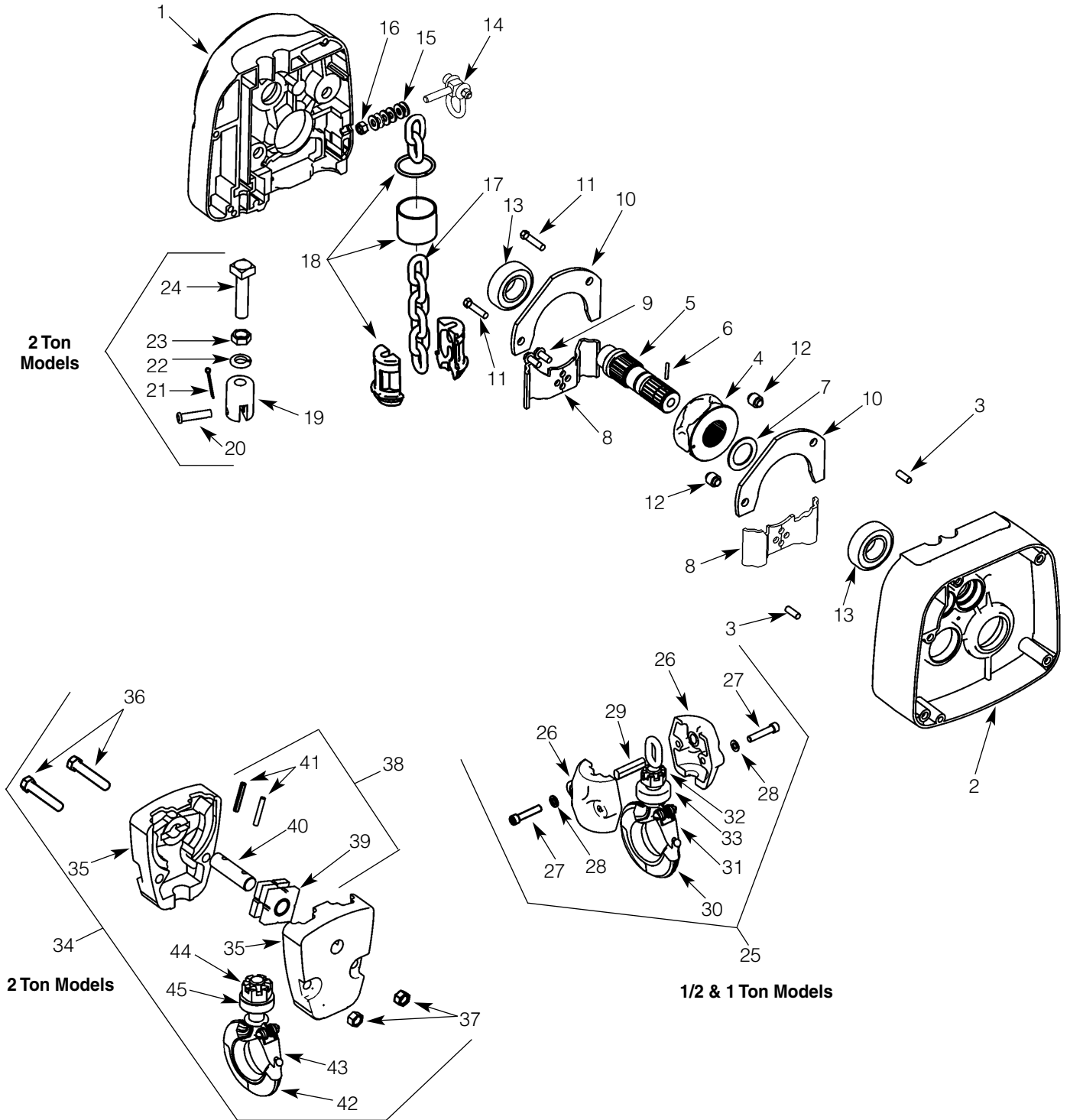

Parts List for Chaining Parts

Ref No.	Description	Part No.	Qty	Ref No.	Description	Part No.	Qty
1	Sheave Housing	JL39	1	25	Load Block Assembly		
2	Gear Housing	JL44	1		1/2 & 1 Ton	913JG3AS	1
3	Dowel pin	H5382	2	26	Load Block Frame	30J14	2
4	Load sheave	JF16-3	1	27	1/4-20UNC X 1¼" Socket Head Cap Screw	S49-77	2
5	Load Sheave Shaft	JL132	1	28	1/4" Internal-Tooth Lockwasher	H4134	2
6	Roll Pin	H5240	1	29	Load Block Pin	18J8	1
7	Spacer	JF285	1	30	Bottom Hook Assembly w/Latch, 1/2 & 1 Ton	3JG20S	1
8	Chain Guide	JF254-3	2	31	Latch Kit	4X1304	1
9	Chain Guide Screw	H2976P	2	32	Slotted Hex Nut	H3986P	1
10	Chain Guide Plate	JF273	2	33	Bearing	JF510	1
11	Chain Guide Plate Screw	H2692P	2	34	Load Block Assembly, 2 Ton	JF914-6	1
12	Chain Guide Plate Spacer	JF127	2	35	Load Block Frame	JF30 1	2
13	Bearing	JF504-2	2	36	Load Block Screw	H2403P	2
14	Shackle Assembly	945KG26	1	37	3/8-24 UNF Hex Locknut	H3964P	2
15	1/4" Flatwasher	H4002P	8	38	Sheave Shaft Assembly	JF917-1	1
16	Dead End Nut	H3845P	1	39	Sheave & Bearing Assembly	JF916	1
17	Load Chain	JL19-1	*	40	Sheave Shaft	JF122-1	1
18	Chain Stop Kit (Kit includes both halves, sleeve, and retaining ring)	75JG6K	1	41	Roll Pin	H5234	2
19	Chain Support	JF109	1	42	Bottom Hook Assembly with Latch, 2 Ton	3KG1W	1
20	Chain Support Pin	JL18	1	43	Latch Kit	4X1305	1
21	Cotter Pin	H5025P	1	44	Slotted Hex Nut	H3991P	1
22	Lockwasher	H4083P	1	45	Bearing	JF511	1
23	1/2-20UNF Hex Jam Nut	H3621P	1				
24	Chain Support Screw	JF703	1				

*** Replacement chain is sold by the foot. For single-chained models, add 2 ft to the lift for the total amount of feet. For double-chained models, double the lift and add 3 ft.**

Optional Accessories

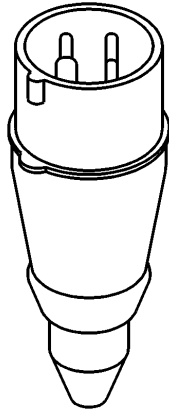

SP851-1
CEE (IEC) Style Plugs
For fast, positive connections.

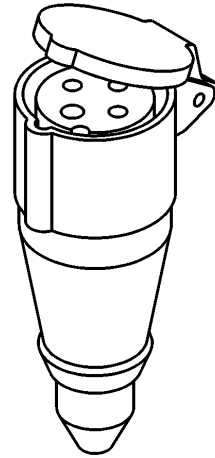

SP851-2
CEE (IEC) Style Connectors
Quick release latches for fast tear downs.

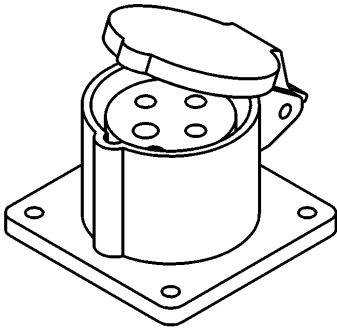

SP851-3
CEE (IEC) Style Control Box Socket
Spring loaded covers for added protection during set-ups.

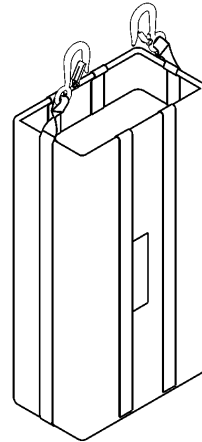

08768W & 08769W
Chain Container
Black finish, light-weight & collapsible for easy storage.

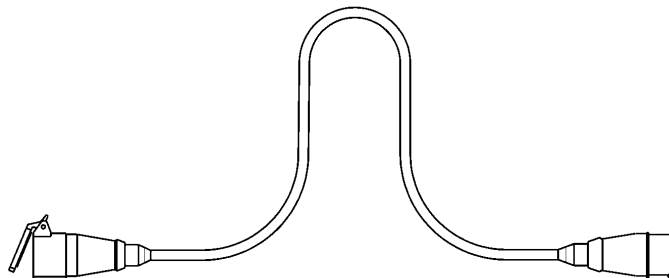

08847W
50' Control Cord
Includes IEC style plug & connector.

