

## Operating, Maintenance & Parts Manual

# SLC Series



### Capacities

**250 lbs (113 kg)    300 lbs (136 kg)**  
**500 lbs (226 kg)    600 lbs (272 kg)**  
**1,000 lbs (453 kg)**

**Follow all instructions and warnings for inspecting, maintaining and operating this hoist.**

The use of any hoist presents some risk of personal injury or property damage. That risk is greatly increased if proper instructions and warnings are not followed. Before using this hoist, each operator should become thoroughly familiar with all warnings, instructions, and recommendations in this manual. **Retain this manual for future reference and use.**

Forward this manual to the hoist operator. Failure to operate the equipment as directed in the manual may cause injury.

Should you have any questions or have problems with this product, please refer to pages 20 and 21.

Before using the hoist, fill in the information below. Refer to the hoist identification plate.

Model Number \_\_\_\_\_

Serial Number \_\_\_\_\_

Purchase Date \_\_\_\_\_

Voltage \_\_\_\_\_

*Authorized Sales & Service*  
**J. HERBERT CORPORATION**  
Call 1-800-255-0588  
407-846-0588 Fax: 846-1066  
info@jherbertcorp.com

Visit us online:  
[www.jherbertcorp.com](http://www.jherbertcorp.com)

# COFFING®

## HOISTS

# SAFETY PRECAUTIONS

Each Coffing SLC Hoist is built in accordance with the specifications contained herein and at the time of manufacture complied with our interpretation of applicable sections of the \*American Society of Mechanical Engineers Code B30.16 "Overhead Hoists," the National Electrical Code (ANSI/NFPA 70) and the Occupational Safety and Health Act. Since OSHA states the National Electrical Code applies to all electric hoists, installers are required to provide current overload protection and grounding in keeping with the code. Check each installation for compliance with the application, operation and maintenance sections of these articles.

The safety laws for elevators, lifting of people and for dumbwaiters specify construction details that are not incorporated into the hoists. For such applications, refer to the requirements of applicable state and local codes, and the American National Safety Code for elevators, dumbwaiters, escalators and moving walks (ASME A17.1). We cannot be responsible for applications other than those for which the equipment is intended.

\*Copies of this standard can be obtained from ASME Order Department, 22 Law Drive, Box 2300, Fairfield, NJ 07007-2300, U.S.A.



**THIS SYMBOL POINTS OUT IMPORTANT SAFETY INSTRUCTIONS WHICH IF NOT FOLLOWED COULD ENDANGER THE PERSONAL SAFETY AND/OR PROPERTY OF YOURSELF AND OTHERS. READ AND FOLLOW ALL INSTRUCTIONS IN THIS MANUAL AND ANY PROVIDED WITH THE EQUIPMENT BEFORE ATTEMPTING TO OPERATE YOUR COFFING SLC HOIST.**



## **WARNING**

**Improper operation of a hoist can create a potentially hazardous situation which, if not avoided, could result in death or serious injury. To avoid such a potentially hazardous situation, THE OPERATOR SHALL:**

1. **NOT** operate a damaged, malfunctioning or unusually performing hoist.
2. **NOT** operate the hoist until you have thoroughly read and understood the manufacturer's Operating, Maintenance and Parts Manual.
3. **NOT** operate a hoist which has been modified without the manufacturer's approval or without certification that it is in conformity with ANSI/ASME B30 volumes.
4. **NOT** lift more than rated load for the hoist.
5. **NOT** use hoist with twisted, kinked, damaged, or worn load chain.
6. **NOT** use the hoist to lift, support, or transport people.
7. **NOT** lift loads over people.
8. **NOT** operate a hoist unless all persons are and remain clear of the supported load.
9. **NOT** operate unless load is centered under hoist.
10. **NOT** attempt to lengthen the load chain or repair damaged load chain.
11. Protect the hoist's load chain from weld splatter or other damaging contaminants.
12. **NOT** operate hoist when it is restricted from forming a straight line from hook to hook in the direction of loading.
13. **NOT** use load chain as a sling, or wrap chain around load.
14. **NOT** apply the load to the tip of the hook or to the hook latch.
15. **NOT** apply load unless load chain is properly seated in the chain sprocket(s).
16. **NOT** apply load if bearing prevents equal loading on all load supporting chains.
17. **NOT** operate beyond the limits of the load chain travel.
18. **NOT** leave load supported by the hoist unattended unless specific precautions have been taken.
19. **NOT** allow the load chain or hook to be used as an electrical or welding ground.
20. **NOT** allow the load chain or hook to be touched by a live welding electrode.
21. **NOT** remove or obscure the warnings on the hoist.
22. **NOT** operate a hoist on which the safety placards or decals are missing or illegible.

23. **NOT** operate a hoist unless it has been securely attached to a suitable support.
24. **NOT** operate a hoist unless load slings or other approved single attachments are properly sized and seated in the hook saddle.
25. Take up slack carefully - make sure load is balanced and load holding action is secure before continuing.
26. Shut down a hoist that malfunctions or performs unusually and report such malfunction.
27. Make sure hoist limit switches function properly.
28. Warn personnel of an approaching load.

## **CAUTION**

**Improper operation of a hoist can create a potentially hazardous situation which, if not avoided, could result in minor or moderate injury. To avoid such a potentially hazardous situation, THE OPERATOR SHALL:**

1. Maintain firm footing or be otherwise secured when operating the hoist.
2. Check brake function by tensioning the hoist prior to each lift operation.
3. Use hook latches. Latches are to retain slings, chains, etc. under slack conditions only.
4. Make sure the hook latches are closed and not supporting any parts of the load.
5. Make sure the load is free to move and will clear all obstructions.
6. Avoid swinging the load or hook.
7. Make sure hook travel is in the same direction as shown on the controls.
8. Inspect the hoist regularly, replace damaged or worn parts, and keep appropriate records of maintenance.
9. Use Coffing recommended parts when repairing the unit.
10. Lubricate load chain per hoist manufacturer's recommendations.
11. **NOT** use the hoist's overload limiting clutch to measure load.
12. **NOT** use limit switches as routine operating stops. They are emergency devices only.
13. **NOT** allow your attention to be diverted from operating the hoist.
14. **NOT** allow the hoist to be subjected to sharp contact with other hoists, structures, or objects through misuse.
15. **NOT** adjust or repair the hoist unless qualified to perform such adjustments or repairs.



Figure 1A

## SPECIFICATIONS

The Coffing SLC is a highly versatile materials handling device that can be used to lift loads that are within its rated load capacity. It is available in five load ratings: 250, 300, 500, 600 and 1,000 pounds (113, 136, 226, 272 and 453 kg).

Standard features of the Coffing SLC include:

- Alloy steel, oblique lay liftwheel that provides constant chain speed and reduces chain wear.
- Hoistaloy® load chain for long and dependable service.
- Grease lubricated, hardened spur gears provide smooth and quiet operation.
- Thermally protected, hoist duty motor.
- Forged steel upper and lower hooks with latch.
- Protector™ that prevents lifting dangerous overloads.
- D.C. disc type motor brake.
- 10 foot (3 M) lift. Longer lifts can be supplied on a per order basis.
- 6 foot (1.8 M) power cord with three prong plug for grounding on 115-1-60 unit.
- Rugged NEMA 4 (weatherproof) control station is suspended on a TYPE SO cord six feet (2.8 M) below the bottom of the hoist. Longer cords can be provided on a per order basis.
- Lightweight die cast aluminum frames and covers.
- Ball or needle bearings at all rotating points.
- Compact, yet rugged, design provides minimum headroom and long, trouble-free service.
- 6 fpm (1.8 m/min) lift speed available on 1000 lbs (453 kg) units.
- 8 fpm (2.4 m/min) lift speed available on 500-600-1000 lbs (226, 272 and 453 kg) units.
- 12 fpm (3.6 m/min) lift speeds available on 500-600-1000 lbs (226, 272 and 453 kg) units.
- 16 fpm (4.9 m/min) lift speeds available on 250-300-500 lbs (113, 136 and 226 kg) units.
- 20 fpm (6.1 m/min) lift speeds available on 500-600 lbs (226 and 272 kg) units.
- 24 fpm (7.3 m/min) lift speeds available on 250-300-500 lbs (113, 136 and 226 kg) units.
- 40 fpm (12.2 m/min) lift speeds available on 250-300 lbs (113 and 136 kg) units.
- 380 to 460-3-50/60, 220 to 240-3-50/60 and 575-3-60 units available. Lift speeds are based on 60 hertz power supply. For 50 hertz power supply lift speeds will be 5/6 of those indicated.
- UL and cUL listed.
- Lifetime Warranty.

## REPAIR/REPLACEMENT POLICY

All SLC Hoists are inspected and performance tested prior to shipment. If any properly maintained hoist develops a performance problem, due to a material or workmanship defect, as verified by Coffing Hoists, repair or replacement of the unit will be made to the original purchaser without charge. This repair/replacement policy applies only to SLC Hoists installed, maintained and operated as outlined in this manual, and specifically excludes hoists subject to normal wear, abuse, improper installation, improper or inadequate maintenance, hostile environmental effects and unauthorized repairs/modifications.

### **WARNING**

Alterations or modification of hoist and use of non-original repair parts can lead to dangerous operation and injury.

#### **TO AVOID INJURY:**

- Do not alter or modify equipment.
- Do use only original replacement parts.

We reserve the right to change materials or design if, in our opinion, such changes will improve our product. Abuse, repair by an unauthorized person, or use of non-original replacement parts voids the guarantee and could lead to dangerous operation. For full Terms of Sale, see Sales Order Acknowledgment. Also, refer to the back cover for Limitations of Warranties, Remedies and Damages, and Indemnification and Safe Operation.

## ACCESSORIES

### Chain Container

This accessory item (Figure 1A) is used to hold the slack chain and it is supplied with mounting hardware and instructions. Chain containers are recommended for those applications where slack chain will interfere with the load or drag on the floor as may more often be the case with the 500, 600 and 1,000 lbs (226, 272 and 453 kg) units. Chain containers are shipped separately and can be furnished for units already in service.

### Series VT-A Trolley

This lightweight, yet rugged, manual push type trolley (Figure 2A, pg 2) is designed to fit a wide range of monorail beams and negotiate tight curves. Provides mobility for your Coffing SLC Hoist.

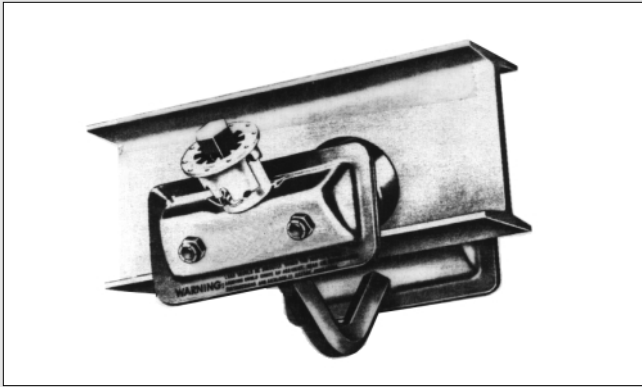

Figure 2A

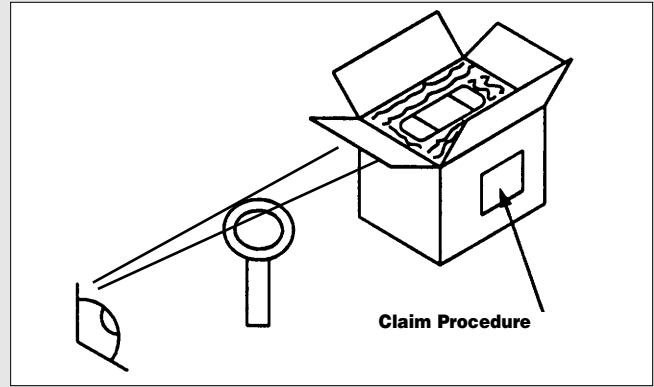

Figure 2B

## INSTALLATION

### UNPACKING

After opening the carton (Figure 2B), carefully inspect the hoist frame, cords, hooks, chain and control station for damage that may have occurred during shipment. If there is damage, refer to the packing slip envelope.

### WARNING

Operating a unit with obvious external damage may cause load to drop and that may result in personal injury and/or property damage.

#### TO AVOID INJURY:

Carefully check unit for external damage prior to installation.

Make sure that the power supply (Figure 3A) to which the hoist is to be connected is the same as that shown on the identification plate located on bottom of hoist.

### MOUNTING THE HOIST

Hang the hoist from its intended support. The structure used to support the hoist must have sufficient strength to withstand several times the load imposed. If in doubt consult a registered engineer and local building codes.

### WARNING

Suspending the hoist from an inadequate support may allow the hoist and load to fall and cause injury and/or property damage.

#### TO AVOID INJURY:

Make sure the structure has sufficient strength to hold several times the hoist and its rated load. Using the upper hook, hang the hoist from the support. **Be sure hoist is solidly held in the uppermost part of the hook arc and the latch is tightly against the hook tip.**

### POWER SUPPLY SYSTEM

(Refer to Figure 4A or 4B on page 4.) To insure proper operation, to avoid damage to hoist and electrical system and to reduce the risk of electric shock or fire, the branch circuit supplying power to the hoist must:

1. Have ample capacity to prevent excessive voltage drop during starting and operation (refer to "Checking for Adequate Voltage at Hoist" on page 3). When determining the size of branch circuit components and conductors, special consideration should be given to the starting current-amps (approximately three times that shown on the hoist identification plate) and the length of the conductors. As a minimum, the system should be rated for 15 amps and it should have #16 AWG, or larger, wiring.

2. Be in accordance with the National Electrical Code (ANSI/NFPA-70) and applicable National, State and Local Codes.
3. Effectively ground the hoist in accordance with National Electrical Code and other applicable codes. Proper grounding provides a path of least resistance for electric current to reduce the risk of electric shock. The power cord of the hoist includes a green-yellow wire for grounding the hoist to the external power supply system. On the standard 115-1-60 unit, the power cord is equipped with a three prong plug. Be sure that the receptacle opening that receives the longest prong is properly grounded. If grounding is to be through the trolley trackwheels, each section of the runway must be grounded to the building ground system using metal to metal connections.

### WARNING

Failure to properly ground the hoist presents the danger of electric shock.

#### TO AVOID INJURY:

Permanently ground the hoist as instructed in this manual.

4. Include slow blow type fuses or inverse trip time circuit breakers to permit the hoist to start and accelerate load.
5. Include a disconnecting means capable of being locked in the "open" position.

### WARNING

Failure to provide a proper power supply system for the hoist may cause hoist damage and offers the potential for a fire.

#### TO AVOID INJURY:

Provide the hoist with a 15 amp, minimum, overcurrent protected power supply per the National Electrical Code (ANSI/NFPA 70) and applicable local codes as instructed in this manual.

**NOTE: IN THIS MANUAL, NOMINAL VOLTAGES ARE USED WHEN REFERRING TO POWER SUPPLY SYSTEMS. HOWEVER, WITH NO MODIFICATION, THE COFFING SLC WILL OPERATE ON A RANGE OF VOLTAGES AS INDICATED BELOW:**

NOMINAL VOLTAGE	VOLTAGE RANGE	HERTZ
230	208-240	60
460	440-480	60
220	200-240	50
380	365-395	50
415	400-430	50
575	550-600	60

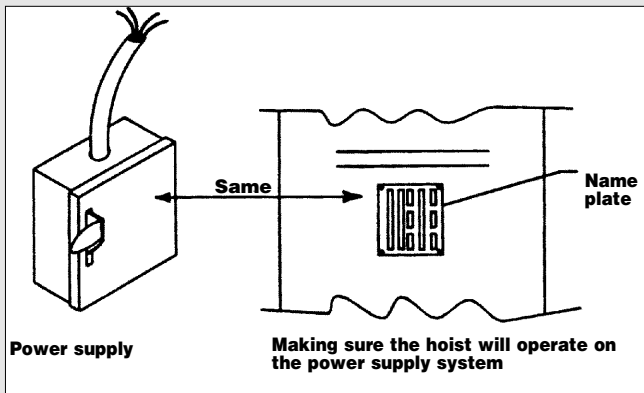

Figure 3A

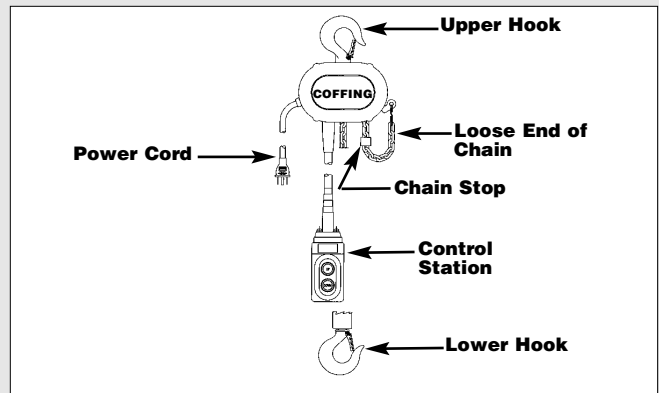

Figure 3B

### Three Phase Hoists

Since the motor in a three phase hoist can rotate in either direction, depending on the manner in which it is connected to the power supply, the direction of hook movement must be checked during the original installation and each time hoist is moved to a new location as follows:

1. Move the manual disconnect switch handle to the "OFF" position.
2. Connect the BROWN, BLUE AND BLACK wires of hoist power cord to load side of disconnect switch. Connect the GREEN-YELLOW wire of hoist power cord to power supply ground.
3. Move the manual disconnect switch handle to the "ON" position.
4. Depress the ↑ (up) control. If the hook moves in the up direction, the hoist is ready for operation. If the hook lowers, move the disconnect switch handle to the "OFF" position and interchange the BLACK and BROWN leads at the disconnect switch. Move the disconnect switch handle to the "ON" position and the hoist is now ready for operation.

### WARNING

Allowing the hook block to run into the bottom of the hoist when raising a load or allowing the chain stop to run into the bottom of the hoist when lowering a load may break the chain and allow the load to drop.

#### TO AVOID INJURY:

Do not allow the hook block or the chain stop to contact the bottom of the hoist.

### Checking for Adequate Voltage at Hoist

The hoist must be supplied with adequate electrical power for proper operation and to reduce problems that may result from insufficient power (low voltage). These include:

- Noisy hoist operation due to brake and/or contactor chatter.
- Heating of the hoist motor and other internal components as well as heating of wires and connectors in the circuit feeding the hoist.
- Failure of the hoist to lift the load due to motor stalling.
- Blowing fuses or tripping circuit breakers.
- Dimming of lights or slowing of motors connected to the same circuit.

NOMINAL POWER SUPPLY	MINIMUM OPERATING VOLTAGE	* MIN. VOLTAGE AT INSTANT OF START
115-1-60	108	103
208-3-60	187	172
220-3-50	198	182
230-3-60	207	190
380-3-50	365	336
415-3-50	399	367
460-3-60	414	380
575-3-60	518	506

For proper operation and to avoid these low voltage problems, voltage (measured at end of the power cord while lifting rated load) should be as the above chart indicates.

**\*The drop in voltage upon energizing the hoist should not be below the value listed.**

Low voltage can also be caused by using an undersized extension cord to supply power to the hoist. The following charts should be used to determine the size wires in the extension cord in order to minimize the voltage drop between the power source and the hoist.

#### 115-1-60 units without contactor (hoists with orange control station)

LENGTH OF CONTROL CORD ft(M)	MAXIMUM LENGTH OF EXTENSION CORD BASED ON SIZE OF WIRE		
	#16 AWG	#14 AWG	#12 AWG
1.0 to 10.0 (0.3 to 3.0)	105 ft (32 M)	170 ft (51 M)	270 ft (82 M)
10.1 to 20.0 (3.1 to 6.0)	75 ft (22 M)	120 ft (36 M)	190 ft (58 M)
20.1 to 30.0 (6.1 to 9.0)	45 ft (14 M)	70 ft (21 M)	110 ft (33 M)
30.1 to 40.0 (9.1 to 12.0)	15 ft (4.5 M)	20 ft (6 M)	35 ft (11 M)

#### 115-1-60 units with contactor and three phase units (hoists with black control station).

Wire Size	MAXIMUM LENGTH OF EXTENSION CORD	
	Single Phase Hoist	Three Phase Hoist
#16 AWG	135 feet(40 M)	245 feet(73 M)
#14 AWG	220 feet(66 M)	395 feet(120 M)
#12 AWG	354 feet(107 M)	630 feet(192 M)

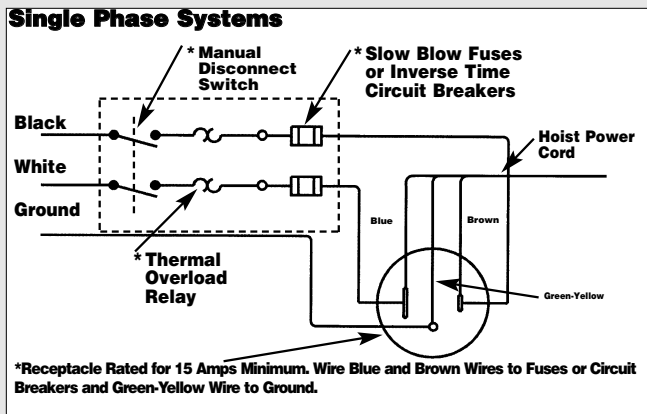

Figure 4A

After the hoist is suspended from its support and you have made sure the power supply complies with the requirements on the previous page, the hoist is ready for operation.

On the 500, 600 and 1,000 lbs (226, 272 and 453 kg) units, cut and discard the ties used to hold the two strands of chain together. With no load on the lower hook, depress the "UP" button in the control station and raise the lower hook until it is about 2 feet below the bottom of the hoist. Check both strands of chains for twists. Twists occur if the lower hook block has been capsized between the strands of chain during packing, shipment and/or handling. Reverse the capsize to remove twists.

### CHAIN CONTAINER

If the chain container is to be used, attach it to the hoist per the instructions provided.

## OPERATING INSTRUCTIONS

The hoist is equipped with a Protector™ that is designed to allow the first gear to slip on an excessive overload. An overload is indicated when the hoist speed slows down, it raises the load in a jerky manner or it will not lift the load at all. Also, some clutching noise may be heard if the hoist is loaded beyond rated capacity. Should this occur, immediately release the "UP" button to stop the operation of the hoist. At this point, the load should be reduced to the rated capacity or the hoist should be replaced with one of the proper capacity. When the excessive load is removed, normal hoist operation is automatically restored.

**CAUTION: The Protector™ is susceptible to overheating and wear when slipped for extended periods. Under no circumstance should the Protector™ be allowed to slip for more than a few seconds.**

Due to the above, the hoist is not recommended for use in any application where there is a possibility of adding to an already suspended load to the point of overload. This includes dumbwaiter installations, containers that are loaded in mid-air, etc. Also, if the hoist is used at unusual extremes of ambient temperatures, above 150° F (65°C), or below 15°F (-9°C), changes in lubricant properties may permit the hoist to raise larger loads than under normal operating conditions and present possibility of damage or injury.

On units without contactor (hoists with orange control station) it is necessary to stop the hoist before changing direction. Therefore, when lowering a load, the push button in the control station must be released momentarily before

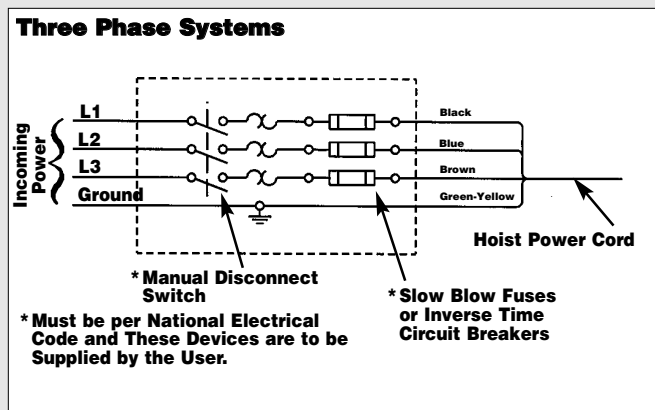



Figure 4B

the "UP" button is depressed to raise the load. If this is not done, the hoist will continue to operate in the down direction while the "UP" push button is depressed, and it will continue to lower the load until the control push button is released. As a result, the direction must not be reversed quickly (plug reversed).

There are no electrical switches to stop the operation of the hoist at the upper and lower limits of lift. As a result, it is necessary to release the push button in the control station to stop the hoist before the hook block or chain stop contacts the bottom of the hoist frame. If the hook block or chain stop contacts the hoist frame, the Protector™ will function to stop the hoisting or lowering operation and protect the hoist components from damage. However, continued, prolonged or repeated slipping of the Protector™ will damage the Protector™ and cause overheating of the internal hoist components.

 <b>WARNING</b>
<p>Allowing the hook block to run into the hoist when raising a load or allowing the chain stop to run into the hoist when lowering a load may break the chain and allow the load to drop.</p>
<p><b>TO AVOID INJURY:</b> Do not allow the hook block or the chain stop to contact the hoist frame.</p>

Hoist operation is controlled by depressing the control station push buttons. (Refer to Figure 5A) Depressing the "UP" push button will move the load hook toward the hoist; depressing the "DOWN" push button will move the load hook away from the hoist.

The "UP" and "DOWN" buttons are momentary type and the hoist will operate in the selected direction as long as the button is held in the depressed position. Release the push button and the hoist will stop.

1. When preparing to lift a load, be sure that the attachments to the hook are firmly seated in hook saddle. Avoid off center loading of any kind, especially loading on the point of the hook.
2. When lifting, raise the load only enough to clear the floor or support and check to be sure that the attachments to the hook and load are firmly seated. Continue lift only after you are assured the load is free of all obstructions.
3. Do not load the hoist beyond the rated capacity shown on the brake end cover. Overloading can cause immediate failure of some load-carrying parts or create a defect causing subsequent failure at less than rated capacity. When in doubt, use the next larger capacity of Coffing SLC Hoist.

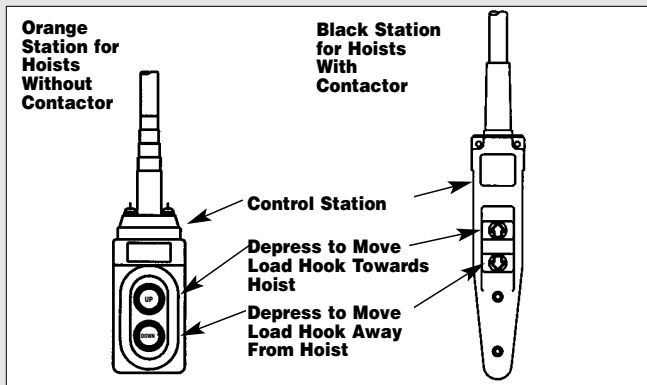

Figure 5A

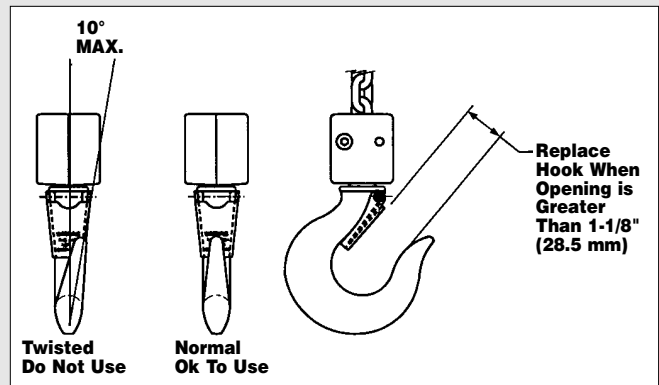

Figure 5B

4. Do not use this or any other overhead materials handling equipment for lifting persons.
5. Stand clear of all loads and avoid moving a load over heads of other personnel. Warn personnel of your intention to move a load in their area.
6. Do not leave the load suspended in the air unattended.
7. Permit only qualified personnel to operate unit.
8. Do not wrap the load chain around the load and hook onto itself as a choker chain.  
Doing this will result in:
  - a. The loss of the swivel effect of the hook which could mean twisted chain and a jammed liftwheel.
  - b. The chain could be damaged at the hook.
9. On the 500, 600 and 1,000 lbs (226, 272 and 453 kg) hoists, check for twists in the load chain. A twist can occur if the lower block has been capsized between the strands of chain. Reverse the capsize to remove twist.
10. Do not allow a load to bear against the hook latch. The latch is to help maintain the hook in position while the chain is slack before taking up the slack chain.

<b style="font-size: 1.2em; margin-left: 10px;">WARNING</b>
<p>Allowing a load to bear against the hook latch and/or hook tip can result in loss of load.</p>
<p><b>TO AVOID INJURY:</b> Do not allow a load to bear against the hook latch and/or hook tip. Apply load to hook bowl or saddle only.</p>

11. Take up a slack load chain carefully and start load easily to avoid shock and jerking of hoist chain. If there is any evidence of overloading, immediately lower the load and remove the excess load.
12. Do not allow the load to swing or twist while hoisting.
13. Never operate the hoist when flammable materials or vapors are present. Electrical devices produce arcs or sparks that can cause a fire or explosion.
14. **STAY ALERT!** Watch what you are doing and use common sense. Do not use the hoist when you are tired, distracted or under the influence of drugs, alcohol or medication causing diminished control.

<b style="font-size: 1.2em; margin-left: 10px;">WARNING</b>	
<b>TO AVOID INJURY:</b>	
<ul style="list-style-type: none"> <li>-DO NOT Lift more than rated load.</li> <li>-DO NOT Operate with twisted, kinked or damaged chain.</li> <li>-DO NOT Operate damaged or malfunctioning hoist.</li> <li>-DO NOT Lift people or loads over people.</li> <li>-DO NOT Operate hoist when load is not centered under hoist.</li> <li>-DO NOT Permit lower hook block to contact hoist frame or chain container.</li> </ul>	<ul style="list-style-type: none"> <li>-DO Replace damaged or malfunctioning hook latch.</li> <li>-DO Keep load chain well oiled.</li> <li>-DO READ ASME B30.16 Safety Code for Hoist and appropriate operating instructions.</li> </ul>

## MAINTENANCE

### INSPECTION

To maintain continuous and satisfactory operation, a regular inspection procedure must be initiated so that worn or damaged parts can be replaced before they become unsafe. The intervals of inspection must be determined by the individual application and are based upon the type of service to which the hoist will be subjected. The inspection of hoists is divided into two general classifications designated as "frequent" and "periodic".

#### Frequent Inspections

These inspections are usually visual examinations by the operator or other designated personnel. Frequent inspections are to be performed daily or monthly and shall include the following items:

- a. Operate the hoist, with no load, and check for visual signs or abnormal noises which could indicate a potential problem - daily.
- b. Brake for evidence of slippage - daily.
- c. Chain for lubricant, wear, damaged links or foreign material - daily (see below).
- d. Hooks for damage, cracks, twist, latch engagement and latch operation - daily (see below).

Any deficiencies must be corrected before the hoist is returned to service.

#### Periodic Inspections

These are visual inspections by an appointed person who records apparent external conditions to provide a basis for continuing evaluation. Periodic inspections are to be performed semi-annually and they should include the following:

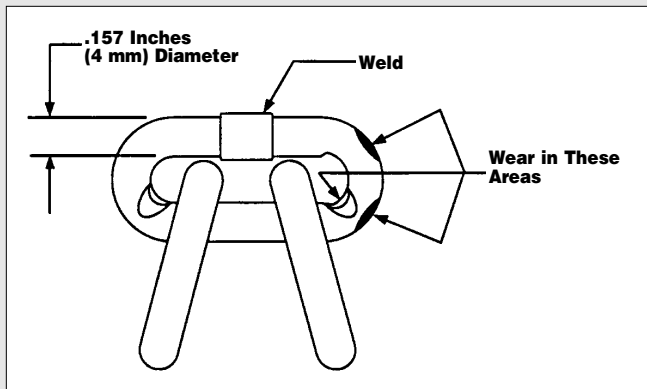

Figure 6A

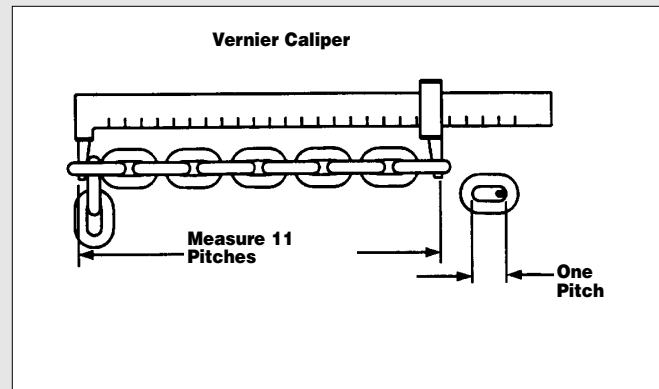

Figure 6B

- a. All items listed under frequent inspections.
- b. External evidence of loose screws.
- c. External evidence of worn, corroded, cracked or distorted hook block, gears, bearings, chain stop and hook retainer.
- d. External evidence of damage or excessive wear of the liftwheel or sheave (double reeved unit). Widening and deepening of pockets may cause chain to lift-up in the pockets and cause binding between liftwheel and chain guide or between lower sheave and hook block. Check chain guide for wear or burring where the chain enters the hoist. Severely worn or damaged parts should be replaced.
- e. External evidence of excessive wear of brake parts - see page 8.
- f. Check the control station push buttons to make sure they operate freely and spring back when released.
- g. Check power cord, control cord and control station for damaged insulation.
- h. Check for pitting and any deterioration of contactor contacts (hoists with black control station).
- i. Check the chain pin or dead end pin and chain stop for wear and cracks.
- j. Check for lubricant leaks at gasket between main frame and gear housing. Tighten gear housing screws to stop leak. If leak persists, replace gasket.
- k. Inspect splines on first pinion shaft and motor coupling for signs of wear or deterioration. Replace splined parts if worn or damaged.

**NOTE: To perform some of the periodic inspections, it is necessary to partially disassemble the hoist. Refer to Disassembly - Assembly starting on page 12.**

Any deficiencies noted must be corrected before the hoist is returned to service. Also, the external conditions may show the need for more detailed inspection which, in turn, may require the use of nondestructive-type testing.

Any parts that are deemed unserviceable are to be replaced with new parts before the unit is returned to service. It is very important that the unserviceable parts be destroyed to prevent possible future use as a repair item and properly disposed of.

### Hook Inspection

Hooks damaged from chemicals, deformations or cracks or that have more than a 10° twist from the plane of the unbent hook or excessive opening must be replaced.

Any hook that is twisted or has excessive throat opening indicates abuse or overloading of the unit. Other load-sustaining components of the hoist should be inspected for damage.

On latch type hooks, check to make sure that the latch is not damaged or bent and that it operates properly with sufficient spring pressure to keep the latch tightly against the tip of the hook and allow the latch to spring back to the tip when released. If the latch does not operate properly. It should be replaced. See Figure 5B, pg. 5 to determine when the hook must be replaced.

### LOAD CHAIN

Chain should feed smoothly into and away from the hoist or hook block (500, 600 and 1,000 lbs, 226, 272 and 453 kg units). If chain binds, jumps or is noisy, first clean and lubricate it (see below). If trouble persists, inspect chain and mating parts for wear, distortion or other damage.

### Chain Inspection

First clean chain with a non-caustic/non-acid type solvent and make a link by link inspection for nicks, gouges, twisted links, weld spatter, corrosion pits, striations (minute parallel lines), cracks in weld areas, wear and stretching. Chain with any one of these defects must be replaced.

Slack the portion of the chain that normally passes over the liftwheel. Examine the interlink area for the point of maximum wear (polishing, see Figure 6A). Measure and record the stock diameter at this point of the link. Then measure stock diameter in the same area on a link that does not pass over the liftwheel (use the link adjacent to the loose end link for this purpose). Compare these two measurements. If the stock diameter of the worn link is 0.010 inches (0.254mm), or more, less than the stock diameter of the unworn link, the chain must be replaced.

On the 500, 600 and 1,000 lbs (226, 272 and 453 kg) units, repeat this examination of the chain that passes through the hook block.

Also check chain for stretch using a vernier caliper as shown in Figure 6B. Select an unused, unstretched section of chain (usually at the loose end) and measure and record the length over 11 chain links (pitches). Measure and record the same length on a worn section of chain. Obtain the amount of stretch and wear by subtracting the measurement of the unworn section from the measurement of the worn section. If the result (amount of stretch and wear) is greater than 0.145 inch (3.7mm), the chain must be replaced.

Use only a "Knife-edge" caliper to eliminate possibility of false reading by not measuring full pitch length.

Note that worn chain can be an indication of worn hoist components. For this reason, the hoist's chain guide, hook block and liftwheel should be examined for wear and replaced as necessary when replacing worn chain.



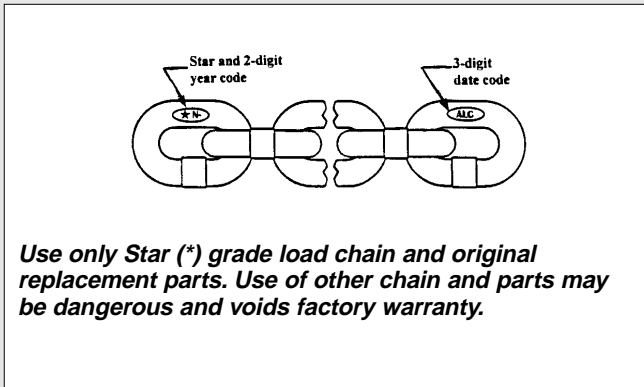

Figure 7A

Also, these chains are specially heat treated and hardened and should never be repaired.

<b>! WARNING</b>
Use of commercial or other manufactures' chain and parts to repair SLC Hoists may cause load loss.
<b>TO AVOID INJURY:</b> Use only factory supplied replacement load chain and parts. Chain and parts may look alike, but factory original chain and parts are made of specific materials or processed to achieve specific properties. See Figure 7A.

**IMPORTANT: Do not use replaced chain for other purposes such as lifting or pulling. Load chain may break suddenly without visual deformation. For this reason, cut replaced chain into short lengths to prevent use after disposal.**

### Chain Lubrication

A small amount of lubricant will greatly increase the life of load chain. Do not allow the chain to run dry. Keep it clean and lubricate at regular intervals with Lubriplate® Bar and Chain Oil 10-R (Fiske Bros. Refining Co.) or equal lubricant. Normally, weekly lubrication and cleaning is satisfactory, but under hot and dirty conditions, it may be necessary to clean the chain at least once a day and lubricate it several times between cleanings.

<b>! WARNING</b>
Used motor oils contain known carcinogenic materials.
<b>TO AVOID HEALTH PROBLEMS:</b> Never use used motor oils as a chain lubricant. Only use Lubriplate® Bar and Chain Oil 10-R as a lubricant for the load chain.

When lubricating the chain, apply sufficient lubricant to obtain natural run-off and full coverage, especially in the interlink area.

### LUBRICATION

Refer to Exploded View and Parts List pages 14 thru 18.

<b>! WARNING</b>
The lubricants used in and recommended for the Coffing SLC may contain hazardous materials that mandate specific handling and disposal procedures..
<b>TO AVOID CONTACT AND CONTAMINATION:</b> Handle and dispose of lubricants only as directed in applicable material safety data sheets and in accordance with applicable local, state and federal regulations.

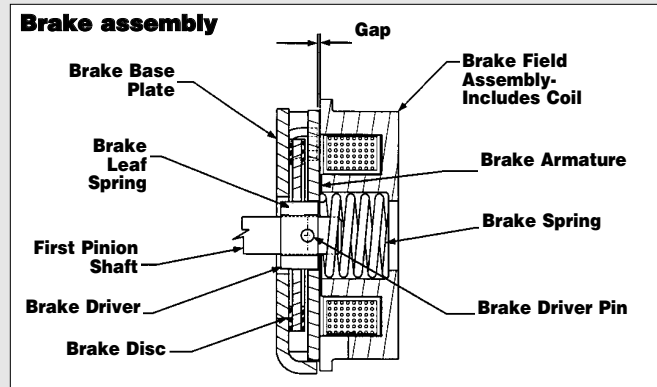

Figure 7B

**NOTE: To assure extra long life and top performance, be sure to lubricate the various parts of the Coffing SLC using the lubricants specified below. If desired, these lubricants may be purchased from Coffing. Refer to page 18 for information on ordering the lubricants.**

### Gears

- The Protector™ (620-111) should operate for the normal life of the hoist without service. The device has been lubricated and calibrated by COFFING and should not be adjusted.

**CAUTION: The Protector™ is to be used with "American Lubricants #1029" grease. Do not use any other grease or the Protector™ will not operate properly and parts could be damaged.**

The gears and Protector are packed at assembly with grease and should not need to be renewed unless the gears have been removed from the housing and degreased.

**CAUTION: Never degrease the Protector™ or attempt to disassemble this device. Degreasing the Protector™ may damage parts and using a device that has been degreased may cause erratic, inconsistent operation. If the Protector™ has been degreased, it must be replaced by a Coffing calibrated device.**

If the gears are removed from the housing, wipe the excess grease off the outside surfaces of the Protector™ with a soft cloth and degrease the remaining gears and housings. Upon reassembly, add 2 oz. of the above grease to gears and housing. Also, coat the spline on the end of the first pinion and shaft (620-131) with a Molydisulphide lubricant such as Moly-Duolube 67 (Hercules Packing Co.).

### Bearings

Rotor bearings (620-102 and 620-103) are pre-lubricated and require no lubrication. Needle bearings (620-109, 620-114, 620-115, 620-128 and 620-164) are packed at assembly with grease and should not need to be relubricated. However, if the housings (620-113 and 620-107), liftwheel (620-127) or sheave wheel (620-162) have been degreased, these bearings should be greased using "American Lubricants #1029" grease.

### Seals

When reassembling the unit, wipe the inside surface of the seals (620-108 and 620-130) with "American Lubricants #1029" grease.

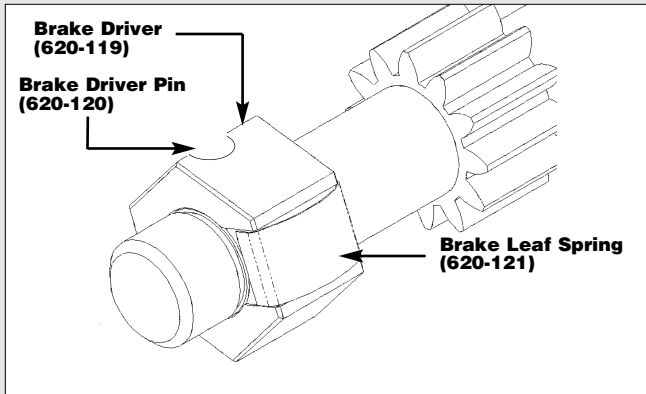

Figure 8A

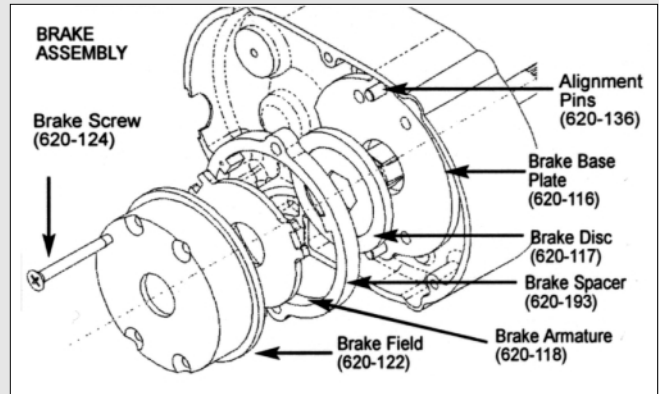

Figure 8B

### Hook Block

If the hook blocks are disassembled for inspection purposes, wipe the grease from the hook knob and the hook knob cavities in the hook blocks. At reassembly, coat the underside of the hook knob and the knob bearing surfaces of cavities in the hook blocks with Molykote BR-2-S (Dow Corning Corp.) grease or equivalent.

### Chain Guide, Liftwheel and Sheave Wheel

- When the hoist is disassembled for inspection and/or repair, the chain guide, stripper, sheave wheel (on double chain unit) and liftwheel must be lubricated with Lubriplate® Bar and Chain Oil 10-R (Fiske Bros. Refining Co.) prior to reassembly. The lubricant must be applied in sufficient quantity to obtain natural runoff and full coverage of these parts.

### Load Chain

Refer to page 7 for lubrication of the load chain.

### Exterior Finish

The exterior surface of the hoist has a durable, scratch resistant baked powder coating. Normally, the exterior surfaces can be cleaned by wiping with a cloth.

### ELECTRIC BRAKE

The brake is non-adjustable with a nominal .004 inch (0.102 mm) air gap and the brake disc must be replaced when the air gap reaches .012 inch (0.305 mm). The brake spacer should be no more than .012 inch (0.305 mm) thicker than the combined thickness of the brake disc and armature plate. Refer to Figure 7B, pg. 7.

To inspect the brake gap, disconnect the hoist from power and remove brake end cover (620-132).

	WARNING
Failure to follow proper lockout/tagout procedures may present the danger of electrical shock.	
<b>TO AVOID INJURY:</b>	
Disconnect power and lockout/tagout disconnecting means before removing cover or servicing this equipment.	

- Refer to Figure 8B and disassemble the brake. Depress and hold the field assembly (620-122) while removing the four brake screws (620-124). The field assembly is under spring pressure and will spring-out if not held. During disassembly, note there is a small leaf spring (620-121) on the brake driver (620-119) and this will spring-out when the brake disc (620-117) is removed. Examine the base plate (620-116), hex driver (620-119), brake disc (620-

- 117) and armature (620-118) for excessive wear, scoring or warpage. Make sure the brake disc is not glazed, the coil firmly fixed in the field (620-122) and the brake spring (620-123) is not damaged. Worn, scored, warped, glazed or damaged parts should be replaced before proceeding.

2. Reassemble the brake making sure to install and compress the leaf spring on the brake driver while sliding the brake disc onto the driver.
3. Install the four brake screws through the brake parts and mount the brake on the gear housing (620-113). Tighten the four brake screws (620-124) to 25 in.lb. (2.8 NM).

### PROTECTOR™

The Protector™ should operate for the normal life of the hoist without service. The device has been lubricated and calibrated and it should not be adjusted. If the Protector™ is not operating properly (see testing on page 7), it must be replaced with a properly calibrated unit from the factory.

### PREVENTATIVE MAINTENANCE

A preventative maintenance program should be established to prolong the useful life of the hoist and maintain its reliability and continued safe use. The program should include the periodic and frequent inspections with particular attention being paid to the lubrication of the various components using the recommended lubricants (see page 18).

### RECOMMENDED SPARE PARTS

To insure continued service of the Coffing SLC, the following is a list of parts that are recommended to be kept on hand at all times to replace parts that have worn or failed. Parts applicable to your hoist should be stocked.

KEY. NO.	PART NAME	QTY. PER HOIST	KEY. NO.	PART NAME	QTY. PER HOIST
620-122	BRAKE FIELD ASSEM.	1	620-117	BRAKE DISC	1
620-186	CONTROL STATION (ORANGE)	1	620-110	CUT-OUT DEVICE	1
620-106	CAPACITOR	1	620-178	REVERSING CONTACTOR	1
620-181	TRANSFORMER	1	627-563	CONTROL STATION PARTS KIT	1
627-565	CONTROL STATION	1			

Refer to page 13 for ordering instructions and the Parts List for part numbers.

# TROUBLE SHOOTING

Always disconnect unit from the power supply system before removing hoist covers or the back cover of control station.



## WARNING

Failure to follow proper lockout/tagout procedures may present the danger of electrical shock.

### TO AVOID INJURY:

Disconnect power and lockout/tagout disconnecting means before removing cover or servicing this equipment.

#### — Probable Cause —

#### — Remedy —

<b>1. Hook does not respond to control station.</b>	
A. No voltage at hoist.	A. Check for blown fuse or tripped circuit breaker or open disconnect switch in main line or branch circuit. Replace fuse, reset circuit breaker or close switch.
B. Open control circuit due to loose connections or broken wires in circuit; motor thermal protector open; control station contacts not closing; open or shorted winding in transformer; transformer thermal cut-out open; mechanical binding in contactor; open or shorted winding in contactor coil.	B. Check electrical continuity through motor thermal protector. If it is open, allow motor to cool. If this does not correct the trouble, use wiring diagram to check electrical continuity of wiring, transformer, contactor and control station contacts. Repair wiring or replace defective part.
C. Wrong voltage or frequency.	C. Make sure that the power supply to hoist is the same as that shown on the identification plate on bottom of hoist.
D. Low voltage.	D. Check power supply system to make sure it complies with the requirements listed under "power supply system" starting on page 2.
E. Brake not releasing due to open or shorted coil, defective diodes or brake disc binding.	E. Check coil continuity, diodes (see page 10) and connections. Make sure brake disc slides freely on brake driver and brake spring is not broken. Replace coil (brake field), repair connections, remove burrs from brake driver so that brake disc slides freely and/or replace brake spring.
F. Excessive load.	F. Reduce load to capacity limit as indicated on identification and capacity labels on hoist.
G. Phase failure (single phasing-three phase units only) - open circuit, grounded or faulty connection in one line of power supply system, hoist wiring, contactor, motor leads or windings.	G. Check for electrical continuity and repair or replace defective part.
<b>2. Hook moves in wrong direction.</b>	
A. Wiring connections reversed in control station or hoist.	A. Use wiring diagram and check wiring connections.
B. Failure of cut-out device (single phase units only) to effect dynamic braking at time of reversal.	B. Check connections to cut-out device. Replace damaged device or faulty capacitor.
C. Phase Reversal (three phase units only).	C. See "Three Phase Hoists" on page 3.
<b>3. Hook lowers but will not raise.</b>	
A. Excessive load.	A. See item 1F.
B. Hoisting circuit is OPEN due to loose connections or broken wires in circuit; control station contacts are not making; open or shorted winding in contactor coil.	B. Use wiring diagram to check electrical continuity of wiring and control station contacts. Repair wiring or replace defective part.
C. Motor cut-out device not operating. (single phase units only).	C. Check cut-out device and connections to same. See page 10. Repair connections and/or replace cut-out device.
D. Phase failure (three phase units only).	D. See item 1G.
<b>4. Hook raises but will not lower.</b>	
A. Lowering circuit is OPEN due to loose connections or broken wires; control station contacts not closing; open or shorted winding in contactor coil.	A. See item 1B.
B. Motor cut-out device not operating (single phase units only).	B. See item 3C.
C. Phase reversal (three phase units only).	C. See item 2C.
D. Phase failure (three phase units only).	D. See item 1G.
<b>5. Hook does not stop promptly.</b>	
A. Brake slipping.	A. Check electric brake (see page 8), especially the brake disc for wear or glazing and make sure brake spring is not broken. Replace worn or glazed brake disc or replace brake spring.
B. Excessive load.	B. See item 1F.
<b>6. Hoist operates sluggishly.</b>	
A. Excessive load.	A. See item 1F.
B. Low voltage.	B. See item 1D.
C. Brake dragging.	C. Check electric brake (see page 8). Check to make sure brake disc is free to move on brake driver. Check for warped or bent brake disc and base plate. Free-up brake disc by removing burrs on driver. Replace warped armature base plate or brake disc.
D. Phase failure or unbalanced current in phases (three phase units only).	D. See item 1G.
<b>7. Motor overheats (Hoist will not operate in up or down direction - motor thermal protector open).</b>	
A. Excessive load.	A. See item 1F.
B. Low voltage.	B. See item 1D.
C. Extreme external heat.	C. Above an ambient temperature of 104°F (40°C), the frequency of hoist operation must be limited to avoid overheating the motor. Special provisions should be made to ventilate the space around the hoist and shield it from radiant heat.
D. Frequent starting or reversing.	D. Avoid excessive inching, jogging and reversing. This type of operation drastically shortens motor cut-out device, capacitor, control station and contactor contact life and causes excessive brake wear.
E. Brake dragging.	E. See item 6C.
F. Motor cut-out device not opening start winding circuit (single phase units only).	F. See item 3C.
G. Phase failure or unbalanced current in phases (three phase units only).	G. See item 1G.
<b>8. Hook fails to stop in either direction.</b>	
A. Brake not closing or ineffective.	A. Check electric brake (see page 8), and armature for binding, broken brake spring, first pinion shaft broke, brake driver worn, brake driver pin broke, brake disc worn. Correct binding of armature; replace broken or worn parts.
<b>9. Hook lowers when "UP" button is depressed.</b>	
A. Phase reversal (three phase units only).	A. See item 2C.

# ELECTRICAL DATA

## Open or Short Circuit in Electrical Components

Open circuits in electrical components may be detected by isolating the component and checking for continuity using an ohmmeter. Short circuits are indicated by D.C. resistance substantially below the nominal D.C. resistance. Motor current draw should be measured at the end of the power cord while the hoist is raising rated load. Check cut-out device (on single phase units only) by measuring coil resistance (terminals 3 and 4) and making sure the contact (terminals 2 and 4) is open.

## Electrical Data for Components

### Stators

Volts-Phase-Hertz	Full Load Current (Amps)	Nominal D.C. Resistance (Ohms)
110 to 120-1-50/60	2.7	Yellow to Red: 7.7 Blue to Black: 6.2
220-3-50	1.1	White to Red: 26.8
230-3-60	0.6	White to Black: 26.8 Red to Black: 26.8
380-3-50	0.63	White to Red: 72.6
415-3-50	0.58	White to Black: 72.6
460-3-60	0.88	Red to Black: 72.6
575-3-60	0.4	White to Red: 140.0 White to Black: 140.0 Red to Black: 140.0

### Transformers

Primary	220/380v.	230/460v.	460v.	575v.	575v.
Secondary	48v.	115v.	48v.	115v.	48v.
Leads	Nominal D.C. Resistance (ohms)				
Black to Purple	11.7	71.0	11.9	73	98
White to Red	228.0	224.0	-	-	-
White to Yellow	614.0	902.0	-	-	-
Red to Yellow	384.0	682.0	-	-	-
White to Orange	-	-	916.0	1100	1100

### Coils

	Voltage	Current Draw (Amps)	Nominal D.C. Resistance (Ohms)
Contactor	115	0.02	765
Coils	48	0.2	98.4
Brake	*115	-	*272
Field	**220	-	1120
	***280	-	1608
Cut-out	115	0.1	Terminals 3 to 4: 0.3
Device	220	N.A.	Terminals 3 to 4: 0.8

\*To measure 115 volt brake coil resistance, carefully cut and peel back the shrink tubing on the brake coil leads to expose the diodes. Trace the leads from the coil to the diodes. Connect the ohmmeter leads at the coil side of the diodes (refer to the wiring diagram) and measure the resistance. If coil is ok, reinsulate the brake coil leads and diodes using electrical tape. Diodes are checked by connecting the ohmmeter to the ends of the brake coil leads, checking for an open or short circuit, reversing the connections to the ohmmeter and again checking for an open or short circuit. If there is an indication of an open or short circuit with the original and reversed connections, diodes are defective and the brake field (620-122), which includes the diodes, must be replaced. Usable diodes are indicated by continuity with the original connections and an open circuit when the connections are reversed or, an open circuit with the original connection and continuity with reversed connections.

\*\*220 volt brake coil is used on 220-3-50/60 and, 380-3-50, 415-3-50 and 460-3-60 hoists.

\*\*\*280 volt brake is used on 575-3-60 hoists.

## WIRING DIAGRAMS

THE FOLLOWING WIRING DIAGRAMS ARE REPRESENTATIVE. FOR ACTUAL WIRING DIAGRAM, REFER TO THE DIAGRAM SUPPLIED WITH THE HOIST. NOTE: FOR 575-3-60 UNITS, REFER TO WIRING DIAGRAM SUPPLIED WITH HOISTS.

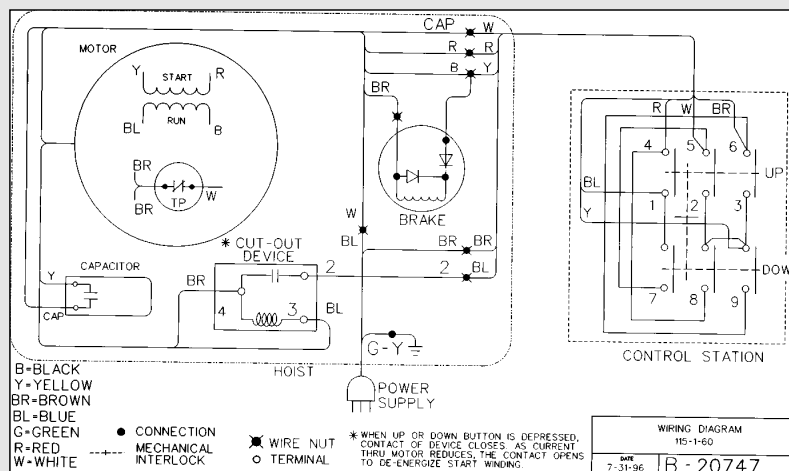

**115-1-60  
 HOISTS WITHOUT  
 CONTACTOR  
 (Orange Control  
 Station)**

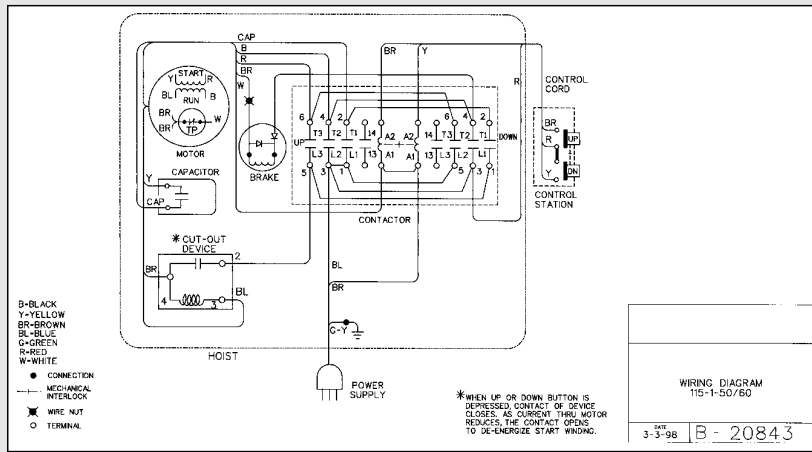

**115-1-60  
HOISTS WITH  
CONTACTOR  
(Black Control  
Station)**

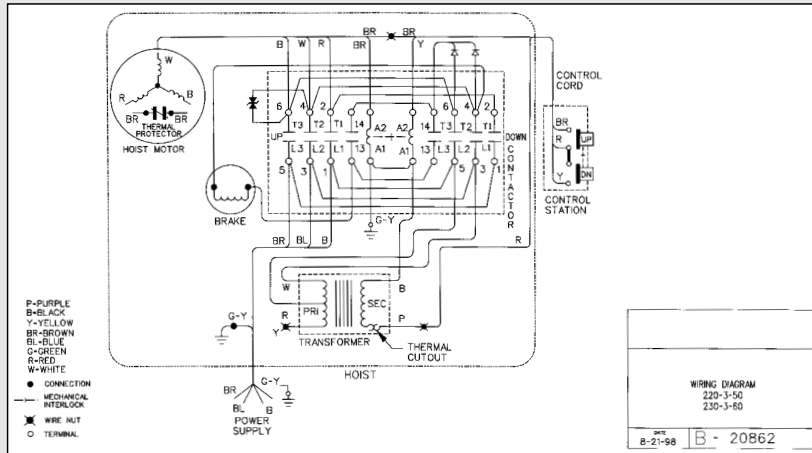

**220-3-50  
230-3-60  
HOISTS WITH  
CONTACTOR  
(Black Control  
Station)**

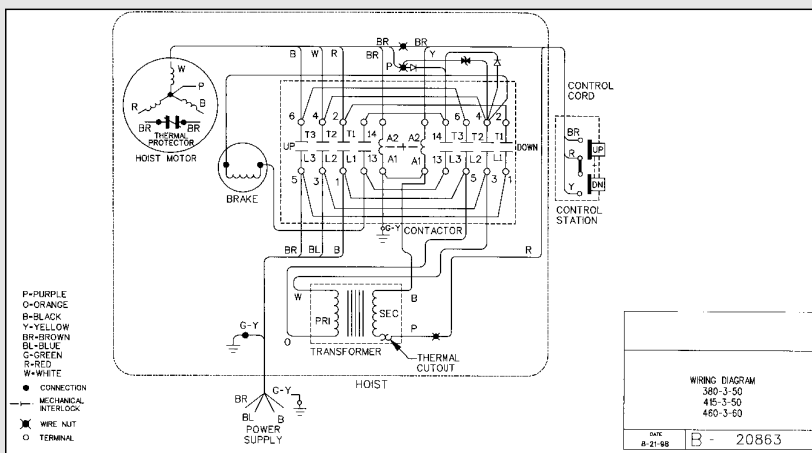

**380-3-50  
415-3-50  
460-3-60  
HOISTS WITH  
CONTACTOR  
(Black Control  
Station)**

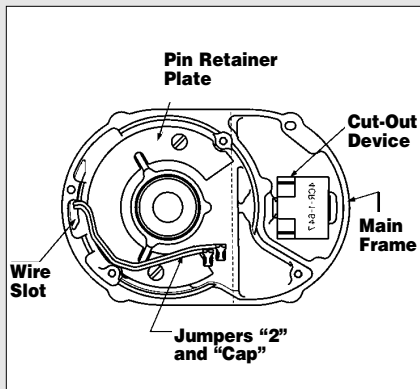

Figure 12A

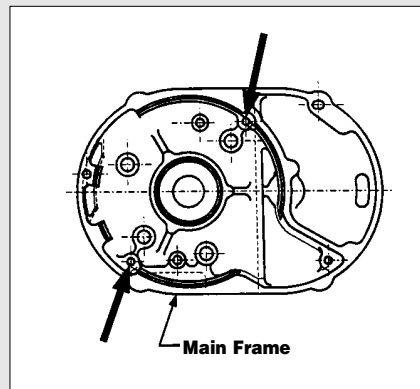

Figure 12B

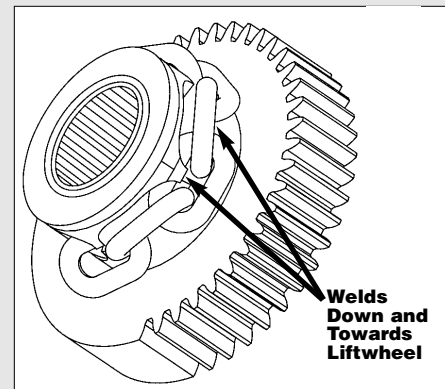

Figure 12C

## DISASSEMBLY-ASSEMBLY

When disassembling and assembling the Coffing SLC, refer to the exploded view and the parts list on pages 14 thru 18. These show the proper relationship of the parts, the names of the parts and the required quantities of the parts. In addition, please observe the following:

1. Needle bearings are pressed into the gear housing (620-113), main frame (620-107), liftwheel (620-127) and lower sheave wheel (620-162). Unless they are to be replaced, do not attempt to remove these bearings.
2. A liftwheel seal (620-108) is pressed into the main frame (620-107) and a seal (620-130) is pressed into the end of the liftwheel shaft (620-148). Be careful that these seals are not cut or damaged during disassembly and reassembly.
3. Refer to page 8 for disassembly, inspection and reassembly of the brake.
4. When removing the brake driver (620-119), it must be supported while driving out the retainer pin (620-120). At reassembly, it must also be supported and the retainer pin must be driven in so that it is below the surface of the driver. File away any burrs and use the brake disc (620-117) as a gauge to make sure it will slide freely on the driver.
5. Do not attempt to disassemble the Protector™ - refer to page 8.
6. Refer to page 7 for lubrication instructions.
7. See next section for load chain removal and installation.
8. Tighten the various screws as follows:

KEY-NO.	PART NAME	SEATING LB. IN.	TORQUE NM
620-126	Pin Retainer Plate Screw	25	2.8
620-154	Motor Cover Screw	25	2.8
620-134	Gear Housing Screw	25	2.8
620-133	Brake End Cover Screw	25	2.8
620-168	Dead End Plate Screw	125	14.1
620-140	Hook Retainer Screw	10	1.1
620-157	Hook Block Screw		
	500 and 600 lbs (226 and 272 kg) units	50	5.6
	250 and 300 lbs (113 and 136 kg) units	125	14.1
620-152	Power Cord Ground Screw	20	2.2

9. When removing the stator (620-100), first remove the brake end cover (620-132). Disconnect stator leads from the wiring or contactor. At the other end, remove the motor end cover (620-105). On single phase units, use an insulated screw driver to short between the bare terminals of the capacitor to discharge it. A spark may be produced. Disconnect wiring to the capacitor and

then remove the capacitor. Remove the cut-out device (620-110) and disconnect the wires from it. Remove the rotor assembly (620-101) and thrust washer (620-104). Then slide the stator out of the main frame (620-107).

10. To install the stator refer to Figure 12A and make sure that the pin retainer plate (620-125) has been assembled to the main frame (620-107). On single phase units slide jumpers "2" and "CAP" through the wire slot in the main frame. Route these wires around the rotor bearing boss in the main frame as shown in Figure 12A. Attach the brown and blue stator leads and "2" jumper to cut-out device (refer to wiring diagram). Slide the cut-out device into the cavity as shown. Push the cut-out device down until it sets on the main frame. Place the capacitor on top of the cut-out device and attach "CAP" jumper and the yellow stator lead to it. Re-route jumpers "2" and "CAP", if necessary to make sure they clear the rotor bearing boss as shown in Figure 12A. On all units slide stator leads through wire slot. Align the slots in the stator shell with the threaded holes in the main frame, as shown in Figure 12B. With the leads down, slide the stator into the main frame. Slide the rotor, large bearing first, into stator. Place the rotor thrust washer (620-104) on top of the exposed rotor bearing and then assemble the motor end cover (620-105) to the main frame. Using wiring diagram, complete the wiring at the brake end of the unit.
11. Make sure the upper hook is properly installed as shown in Figure 13A.
12. After reassembly, test the unit per instructions on page 13.

## LOAD CHAIN REMOVAL/INSTALLATION

1. If unit has a chain container, remove it from the chain guide.
2. Remove the chain stop (620-146). Depress "DOWN" button and run chain out of hoist.
3. Feed a short length of soft wire through the opening between the chain guide (620-141), and stripper (620-143) until it comes out of the hoist. Attach "new" chain to end of the wire which is in the center of the hoist. Position the chain so that the welds will be down and towards the liftwheel as shown above in Figure 12C.
4. Jog the "UP" push button while pulling on the free end of wire until the chain comes out of the hoist. Remove the wire and attach the chain stop as shown in Figure 13B. On units with chain container, place chain stop and loose end of chain in chain container. Attach chain container to chain guide.
5. On the single-chained units, remove the hook block from the old chain and attach it to the new chain by reusing the chain pin (620-158).  
On the double-chained units:
  - Remove dead end plate (620-160) from hoist.
  - Remove dead end pin (620-161) from the last link of chain and pull chain out of dead end plate.
  - Pull old chain out of hook block and disassemble the hook block.

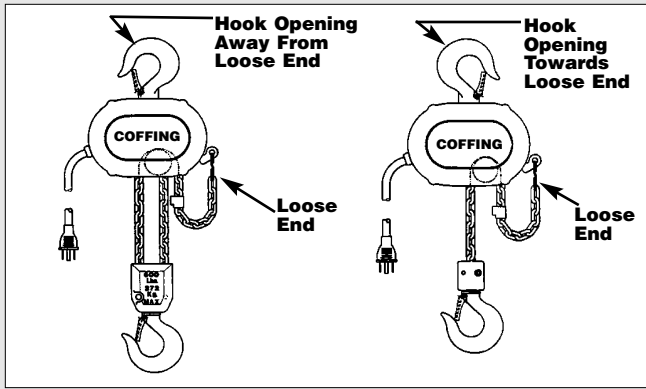

Figure 13A

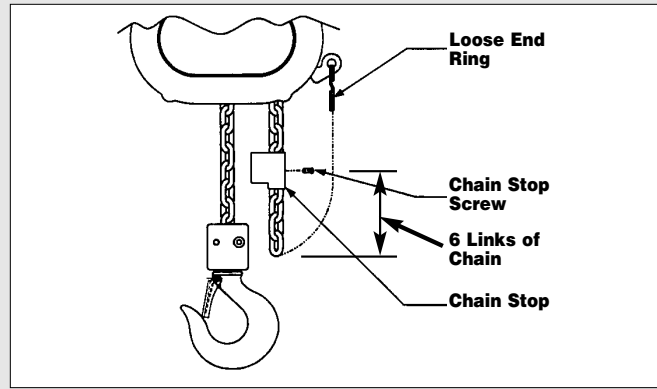



Figure 13B

- Make sure the new chain is not twisted and wrap the chain around the sheave wheel (620-162) with welds down and towards the sheave wheel.
- Reassemble hook block and pull the new chain through the hook block.
- Slide the dead end plate over the last link and secure it using the dead end pin.
- Making sure the chain is not twisted between the hook block and hoist, attach the dead end plate to the stripper (620-143).
- Retrace the new chain and check for twists. If chain is twisted, start over.

**IMPORTANT: Do not use "old" chain for other purposes such as lifting or pulling. Load chain may break suddenly without visual deformation. For this reason, cut the "old" chain into short lengths to prevent use after disposal.**

### CUTTING CHAIN

Hoistaloy® load chain is hardened and it is difficult to cut. The following methods are recommended when cutting a length of new chain from stock or cutting off worn chain. Always wear eye protection when cutting chain.

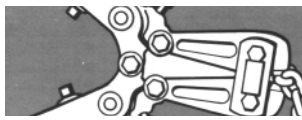
1. Use a grinder and nick the link on both sides (see right), then secure the link in a vise and break off with a hammer. 
2. Use a 7" (177 mm) minimum diameter by 1/8" (3.1 mm) thick abrasive wheel (or type recommended by wheel supplier) that will clear adjacent links.
3. Use a bolt cutter (see right) with special cutter jaws for cutting hardened chain. Jaws should be 1 inch (25.4 mm) long. 

## ! WARNING

Cutting chain can produce flying particles.

### TO AVOID HEALTH PROBLEMS:

- Wear eye protection.
- Place a shield over chain to prevent flying objects.

### TESTING

Before using, all altered, repaired or used hoists that have not been operated for the previous 12 months must be tested by the user for proper operation. First, test the unit without a load and then with a light load of 50 pounds (23 kg) times the number of load supporting parts of load chain to be sure that the hoist operates properly and that the brake holds the load when control is released. Next test with a load of \*125% of rated capacity. In addition hoists in which load

sustaining parts have been replaced should be tested with \*125% of rated capacity by or under the direction of an appointed person and a written report prepared for record purposes. After this test, check the Protector™ functions. If the Protector™ permits lifting a load in excess of 200% of rated load, it should be replaced.

\*If the Protector™ prevents lifting of a load of 125% of rated capacity, reduce load to rated capacity.

**NOTE: For additional information on inspection and testing, refer to ASME B30.16 "Overhead Hoists" obtainable from ASME Order Department, 22 Law Drive, Box 2300, Fairfield, NJ 07007-2300, U.S.A.**

## REPAIR PARTS

### ORDERING INSTRUCTIONS

The following information must accompany all correspondence and orders for replacement parts:

1. Hoist rated load from identification plate.
2. Serial number of the hoist stamped below identification plate.
3. Voltage, Phase, Hertz from identification plate.
4. Length of lift.
5. Key number of part from parts list.
6. Number of parts required.
7. Part name from parts list.
8. Part number from the parts list.

**NOTE: When ordering replacement parts, it is recommended that consideration be given to the need for also ordering such items as gaskets, fasteners, seals, etc. These items may be damaged or lost during disassembly or just unfit for future use because of deterioration from age or service.**

## ! WARNING

Using "commercial" or other manufacturer's parts to repair the Coffing SLC may cause load loss.

### TO AVOID INJURY:

Use only factory supplied replacement parts. Parts may look alike but factory original parts are made of specific materials or processed to achieve specific properties.

**CONTROL STATION (ORANGE) FOR USE ON 115-1-60 HOISTS WITHOUT CONTACTOR**

*NOTE: Individual components are not available for repairs*

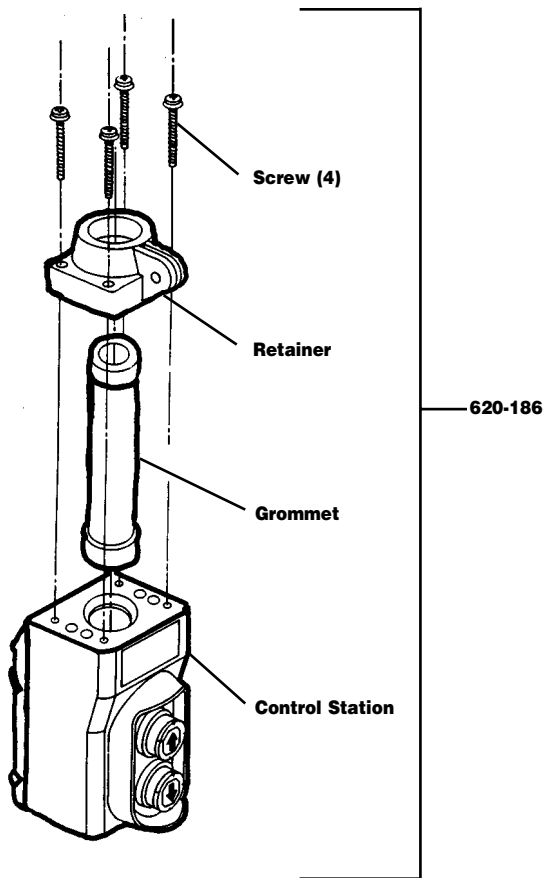

**PARTS LIST**

KEY NO.	No. PART NAME	REQ'D.	PART NUMBER
620-186	Control station with retainer, screws and grommet	1	24805

**PARTS LIST**

Key No.	Part Name	Number Required	Part Number
627-552	Control Station Consists of: 627-553, 627-554, 627-555, 627-563, 627-565 and 627-820	1	*28630
627-551	Control Station Kit Consists of: 1-Neoprene Grommet 1-Grommet Retainer Ring 2-Grommet Retainer Ring Attaching Screw 4-Cover Attaching Screw	1	28627
627-553	Case	1	28873
627-554	Gasket	1	28876
627-555	Cover Assembly (Decal & Rocker included)	1	51477
627-563	Control Station Parts Kit Consists of: 1-Strain Relief Attaching Screw 1-Strain Relief Attaching Screw Washer 2-Switch Mounting Pin 2-Pin Retainer Screw 2-Switch Leaf Spring	1	51481
627-565	Control Station Switch Kit Consists of: 2-Switch 1-Jumper 1-Terminal 1-Screw	1	51472
627-820	Warning Label	1	24842

**Control Station (Black) for use on 115-1-60 hoists with contactor, and three phase units.**

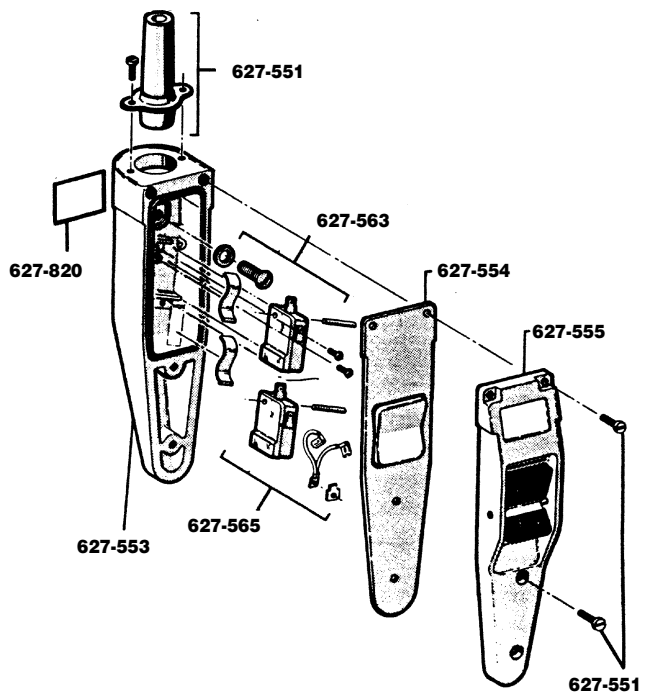

\*Also order Control Station Kit Key No. 627-551, Part No. 28627.





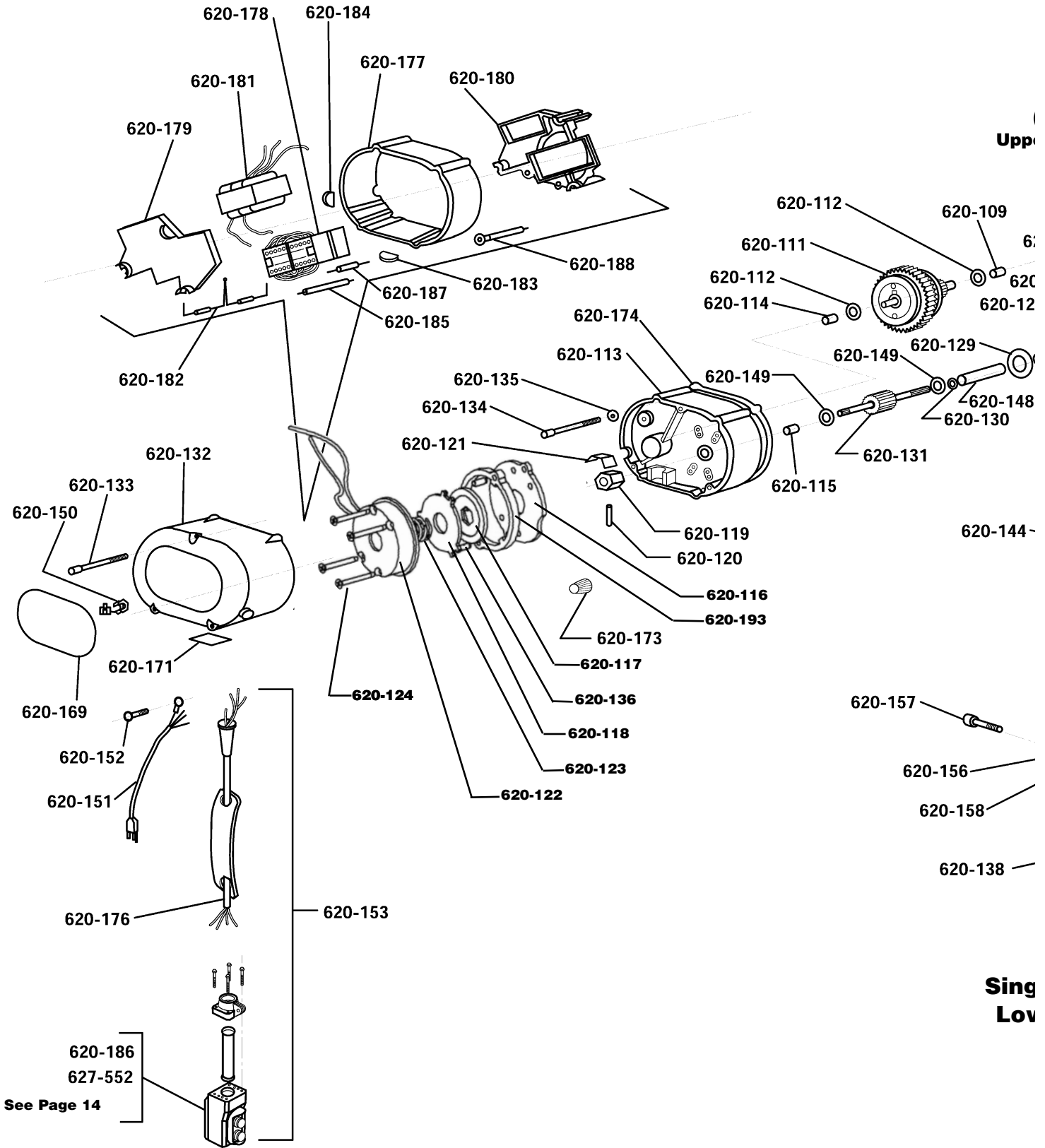

Page 13 for  
ok Installation)

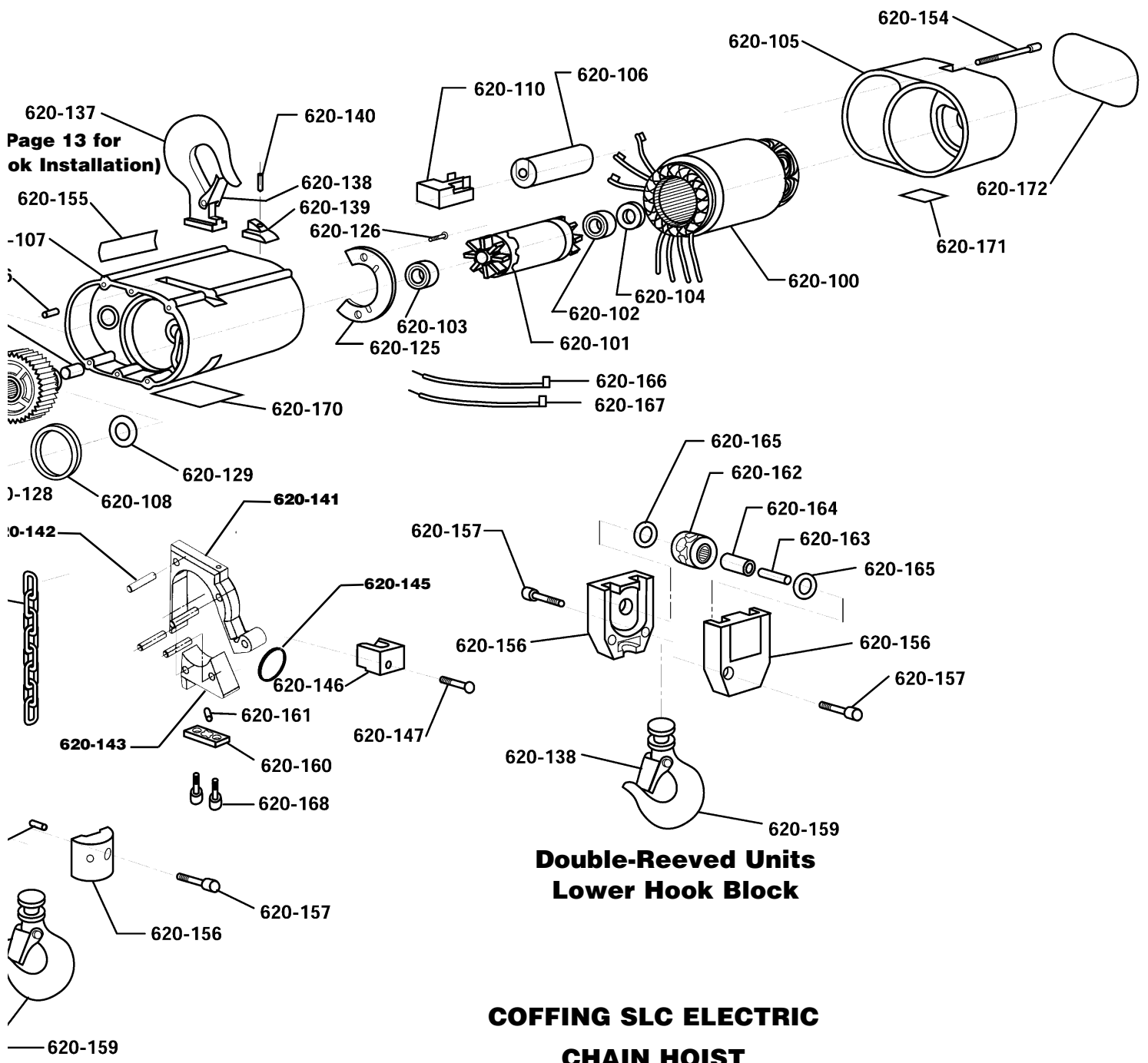

**Double-Reeved Units  
Lower Hook Block**

**COFFING SLC ELECTRIC  
CHAIN HOIST  
EXPLODED VIEW**

Double-Reeved Units  
Hook Block

## COFFING SLC PARTS LIST

KEY NUMBER	PART NAME	NO. REQ'D	PART NUMBER
620-100	STATOR		
	115-1-60 Hoists	1	20707
	220-3-50/60 Hoists	1	20329
	380-3-50, 415-3-50 and 460-3-60 Hoists	1	20330
	575-3-60	1	20344
620-101	ROTOR ASSEMBLY (Includes 620-102 and 620-103)	1	20651
620-102	ROTOR BEARING, OUTBOARD	1	88487
620-103	ROTOR BEARING, INBOARD	1	88486
620-104	ROTOR THRUST WASHER	1	20727
620-105	MOTOR END COVER	1	20356
620-106	CAPACITOR		
	115-1-60 Hoists	1	20708
620-107	MAIN FRAME (Includes 620-108 AND 620-109)	1	20300
620-108	LIFTWHEEL SEAL	1	20705
620-109	PROTECTOR BEARING - MAIN FRAME SIDE	1	88636
620-110	CUT-OUT DEVICE		
	115-1-60 Hoists	1	20709
620-111	PROTECTOR ASSEMBLY		
	6 fpm, 1,000 lbs	1	20663
	8 fpm, 500 & 600 lbs	1	20645
	8 fpm, 1,000 lbs	1	20660
	12 fpm, 500 lbs	1	20663
	12 fpm, 600 lbs	1	20638
	12 fpm, 1,000 lbs	1	20662
	16 fpm, 250 & 300 lbs	1	20645
	16 fpm, 500 lbs	1	20660
	20 fpm, 500 lbs	1	20648
	20 fpm, 600 lbs	1	20661
	24 fpm, 250 & 300 lbs	1	20638
	24 fpm, 500 lbs	1	20662
	40 fpm, 250 lbs	1	20648
40 fpm, 300 lbs	1	20661	
620-112	PROTECTOR THRUST WASHER	2	88640
620-113	GEAR HOUSING	1	20301
	(Includes 620-114 AND 620-115)		
620-114	PROTECTOR BEARING - GEAR HOUSING SIDE	1	88636
620-115	FIRST PINION BEARING	1	88635
620-116	BRAKE BASE PLATE	1	20724
620-117	BRAKE DISC	1	20722
620-118	BRAKE ARMATURE	1	20888
620-119	BRAKE DRIVER	1	20776
620-120	BRAKE DRIVER PIN	1	983976
620-121	BRAKE LEAF SPRING	1	20775
620-122	BRAKE FIELD (Includes Brake Coil)		
	115-1-60 Hoists	1	20659
	220-3-50/60, 380-3-50, 415-3-50 and 460-3-60 Hoists	1	20658
	575-3-60 Hoists	1	20629
620-123	BRAKE SPRING	1	20887
620-124	BRAKE SCREW	4	920740
620-125	PIN RETAINER PLATE	1	20700
620-126	PIN RETAINER PLATE SCREW	2	20743
620-127 (con't)	LIFTWHEEL AND GEAR ASSEMBLY		
	6 fpm, 1,000 lbs	1	20664
	8 fpm, 500, 600 & 1,000 lbs	1	20664
	12 fpm, 500 lbs	1	20664
	12 fpm, 600 & 1,000 lbs	1	20647
	16 fpm, 250, 300 & 500 lbs	1	20664
	20 fpm, 500 & 600 lbs	1	20657

KEY NUMBER	PART NAME	NO. REQ'D	PART NUMBER
620-127	LIFTWHEEL AND GEAR ASSEMBLY		
	24 fpm, 250, 300 & 500 lbs	1	20647
	40 fpm, 250 & 300 lbs	1	20657
620-128	LIFTWHEEL BEARING	2	88637
620-129	LIFTWHEEL THRUST WASHER	2	88638
620-143	STRIPPER	1	20305
620-130	LIFTWHEEL SHAFT SEAL	1	20704
620-131	FIRST PINION AND SHAFT	1	20306
620-132	BRAKE END COVER	1	20323
620-133	BRAKE END COVER SCREW		
	Hoists without contactor	3	920715
	Hoists with contactor	3	20808
620-134	GEAR HOUSING SCREW	4	920718
620-135	GEAR HOUSING SCREW SEAL (No longer used)	4	20701
620-136	FRAME PIN	2	920720
620-137	HOOK (INCLUDES 620-138)	1	20650
620-138	HOOK LATCH KIT	2	595522
620-139	HOOK RETAINER	1	20712
620-140	HOOK RETAINER SCREW	1	920722
620-141	CHAIN GUIDE	1	20304
620-142	CHAIN GUIDE/STRIPPER PIN	4	20729
620-144	LOAD CHAIN -	-	85988
	SPECIFY LIFT OR LENGTH REQ'D		
620-145	LOOSE END RING	1	20744
620-146	CHAIN STOP	1	20319
620-147	CHAIN STOP SCREW	1	25858
620-148	LIFTWHEEL SHAFT	1	20313
620-149	FIRST PINION THRUST WASHER	2	88639
620-150	POWER CORD GROMMET		
	Hoists without contactor	1	20717
	Hoists with contactor	1	20779
620-151	POWER CORD		
	115-1-60 Hoists with contactor	1	20635
	115-1-60 Hoists without contactor	1	20608
	220-3-50/60, 380-3-50, 415-3-50 and 460-3-60 Hoists	1	20628
620-152	POWER CORD GROUND SCREW	1	982877
620-153	CONTROL STATION AND CORD ASSEMBLY		
	(Includes control station, cord, warning tag and upper grommet)		
	Orange Control Station for		
	10 ft lift	1	20607
	15 ft lift	1	20615
	20 ft lift	1	20616
	Black Control Station for		
	10 ft lift	1	20642
	15 ft lift	1	20643
	20 ft lift	1	20644
	For other lifts contact Coffing	-	-
620-154	MOTOR COVER SCREW	3	920719
620-155	CAUTION LABEL	1	20758
620-156	HOOK BLOCK, Single-reeved	2	20889
	HOOK BLOCK, Double-reeved	2	20739
620-157	HOOK BLOCK SCREW, Single-reeved	2	920723
	HOOK BLOCK SCREW, Double-reeved	2	920724
620-158	CHAIN PIN	1	920720
620-159	HOOK (Includes 620-138)	1	23030
	LATCHLOK HOOK	1	40618
620-160	DEAD END PLATE, Double-reeved	1	20714
620-161	DEAD END PIN, Double-reeved	1	920720

## COFFING SLC PARTS LIST

KEY NUMBER	PART NAME	NO. REQ'D	PART NUMBER
620-162	SHEAVE WHEEL W/ 620-164, Double-reeved	1	20652
620-163	SHEAVE WHEEL SHAFT, Double-reeved	1	20318
620-164	SHEAVE WHEEL BEARING, Double-reeved	1	88641
620-165	SHEAVE WHEEL THRUST WASHER, Double-reeved	2	88639
620-166	JUMPER (#2)	1	20610
620-167	JUMPER (CAP)	1	20609
620-168	DEAD END PLATE SCREW, Double-reeved	2	986185
620-169	CAPACITY/WARNING LABEL		
	250 lbs	1	20762
	300 lbs	1	20737
	500 lbs	1	20763
	600 lbs	1	20738
620-170	I.D. LABEL		CONTACT
	ALL HOISTS	1	FACTORY
620-171	WARNING LABEL	2	24842
620-172	COFFING LABEL	1	20901
620-173	WIRE NUT (Specify No. Req'd.)	-	920756
620-174	GASKET	1	20755
620-176	CONTROL CORD ASSEMBLY (includes cord, strain relief and warning tag) for Orange control station and		
	10 ft lift	1	20630
	15 ft lift	1	20631
	20 ft lift	1	20632
	For black control station and		
	10 ft lift	1	51503
	15 ft lift	1	51504
	20 ft lift	1	51505
For other lifts, contact factory	-	-	
620-177	FRAME SPACER	1	20333
620-178	CONTACTOR (includes power jumpers)		
	115 VAC Coils	1	20814
	48 VAC Coils	1	20787

KEY NUMBER	PART NAME	NO. REQ'D	PART NUMBER
620-179	COMPONENTS BOARD-OUTBOARD	1	20777
620-180	COMPONENTS BOARD-INBOARD	1	20778
620-181	TRANSFORMER		
	48 Volt Secondary (220/380 primary)	1	20851
	48 Volt Secondary (460 primary)	1	20834
	115 Volt Secondary (230/460 primary)	1	20831
	115 Volt Secondary (575 primary)	1	20876
	48 Volt Secondary (575 primary)	1	20866
620-182	DIODE ASSEMBLY	1	20789
620-183	CONTROL CORD PLUG	1	20780
620-184	POWER CORD PLUG	1	20781
620-185	CONTACTOR JUMPER (Specify No. Req'd.)	-	20332
620-187	VOLTAGE SUPPRESSOR		
	230-3-50/60, 380-3-50, and 460-3-60 Hoists	1	20861
	575-3-60 Hoists	1	20869
620-188	GROUND JUMPER	1	20641
620-193	BRAKE SPACER	1	20723
620-194	RED STRIPE**	2	20902

\*\* Indicates Not Shown

<b>Part Number for Packaged Lubricants Used in the Coffing SLC</b> <i>(Refer to Page 7 for Lubrication Instructions)</i>		
Lubricant Usage	Type Lubricant	Part Numbers and Packaged Quantity of Lubricants
Hoist Gears	Grease American Lubricants #1029	28605 for 1/2 lb. Can 28616 for 1 lb. Can 28617 for 4 lb. Can
Spline on end First Pinion and Shaft	Oil-Graphite Mixture Hercules Packing Co. Moly-Duolube 67	40628 for 1 Pint Can
Load Chain	Oil Fiske Bros. Lubriplate® Bar and Chain Oil #10R	28608 for 1 Pint Can 28619 for 1 Gal. Can
Lower Hook Knob	Grease Dow Corning Molykote BR-2-S	28606 for 1/2 lb. Can 28618 for 1 lb. Can

When ordering lubricants, specify the type of lubricant, part number and packaged quantity required.

## AUTHORIZED WARRANTY REPAIR CENTERS AND PARTS DEPOTS

As a user of Coffing hoists, you are assured of reliable repair and parts services through a network of Master Parts Depots and Service Centers that are strategically located across the United States, its territories and Canada. These facilities have been selected on the basis of their demonstrated ability to handle all parts and repair requirements promptly and efficiently. Below is a list of the Authorized Warranty Repair Centers and Parts Depots located in United States, its territories and Canada.

### UNITED STATES

#### ALABAMA

\*\*TOOL SMITH CO.  
1300 4th Ave. S.  
Birmingham AL 35233  
(205) 323-2576 or (800) 317-8665  
Fax (205) 323-9060

#### ARKANSAS

\*\*HI-SPEED HOIST & CRANE  
701 N. Maple St.  
N. Little Rock AR 72114  
(501) 375-9178 Fax (501) 375-4254

\*\*HANDLING SYSTEMS & CONVEYORS INC  
10909 East Otter Creek Rd.  
Mabelville AR 72103  
(501) 455-5898 Fax (501) 455-6179

#### ARIZONA

\*\*MECHANICS TOOL SERVICE  
1301 E. Apache Park Place  
Tucson AZ 85714  
(520) 889-8484 AZ only (800) 372-6700  
Fax (520) 889-6668

#### CALIFORNIA

\*\*ARROW CRANE HOIST CORP.  
12714 South Carmanita Road  
Santa Fe Springs CA 90670  
(562) 921-8328 Fax (562) 921-9307

\*\*IDG. CALIFORNIA  
6842 Walker Street  
LaPalma CA 90623  
(714) 994-6960 or (800) 464-5669  
Fax (562) 948-4448

\*\*CRANEWORKS, INC.  
2585 Nicholson Street  
San Leandro CA 94577  
(510) 357-4000 Fax (510) 357-4099

\*\*KIMMERLE BROTHERS, INC.  
12060 East Florence St.  
Santa Fe Springs CA 90670  
(562) 946-6771 Fax (562) 944-3473

\*\*KIMMERLE BROTHERS, INC.  
226 11th St.  
San Francisco CA 94103  
(415) 431-1163 Fax (415) 431-1693

\*\*KIMMERLE BROTHERS, INC.  
337 "M" St.  
Fresno CA 93721  
(559) 233-1278 Fax (559) 233-4678

#### COLORADO

\*\*CRANE REPAIR CO.  
3718 Norwood Drive  
Littleton CO 80125  
(303) 791-7918 or (800) 878-7918  
Fax (303) 791-7179

#### DELAWARE

\*\*P & H MORRIS MATERIAL HANDLING  
137 Sandy Drive  
Newark DE 19713  
(302) 369-5819 or (800) 346-2098  
Fax (302) 369-5829

#### FLORIDA

\*\*J. HERBERT CORP  
1751 S. John Young Parkway  
Kissimmee FL 32741  
(407) 846-0588 or (800) 814-4670  
Fax (407) 846-8042

#### FLORIDA (cont'd)

\*\*MATERIAL HANDLING SYSTEMS  
720 S.W. 4th Court  
Dania FL 33004  
(954) 921-1171 or (888) 424-6478  
Fax (954) 921-7117

#### GEORGIA

\*\*ACE INDUSTRIES INC.  
6295 McDonough Drive  
Norcross GA 30093  
(770) 441-0898 or (800) 733-2231  
Fax (800) 628-3648

\*GAFFEY INC.  
471 Sessions St.  
Marietta GA 30060  
(770) 939-6443 or (800) 820-6443  
Fax (770) 422-2255

#### ILLINOIS

\*\*INDUSTRIAL TOOL PRODUCTS  
919 N. Central Ave.  
Wooddale IL 60191  
(630) 766-4040 or (800) 525-9654  
Fax (630) 766-4166

\*S & K AIR POWER  
Rt. 316 E., Box 1279  
Mattoon IL 61938  
(217) 258-8500 (IL only-800-955-8501)  
Fax (217) 258-8571

\*\*SIEVERT ELECTRIC SERVICE  
1230 South Hannah  
Forest Park IL 60130  
(708) 771-1600 or (800) 322-9144  
Fax (708) 771-3124

#### INDIANA

\*\*BREHOB CORP.  
1334 S. Meridian St.  
Indianapolis IN 46225  
(317) 231 8080 or (800) 632-4451  
Fax (317) 231-8072

\*\*MATERIALS HANDLING EQUIPMENT  
7433 US 30 East  
Fort Wayne IN 46803  
(219) 749-0475 or (800) 443-6432  
Fax (219) 749-0481

#### IOWA

\*\*ALTER & SONS, INC.  
514 S. Howell St.  
Davenport IA 52808  
(319) 323-3601 or (800) 553-1111  
Fax (319) 324-0138

#### KENTUCKY

\*\*ADVANCED SHERMAN  
330 North Spring St.  
Louisville KY 40206  
(502) 896-2166 (KY only-800-633-8186)  
Fax (502) 897-9837

#### LOUISIANA

\*\*RENTAL SERVICE  
3301 Cities Service Hwy  
West Lake LA 70669  
(318) 882-6011 Fax (318) 882-0527

#### LOUISIANA cont'd

\*\*DRILLCO  
12649 S. Choctaw Dr.  
Baton Rouge LA 70815  
(504) 272-8251 or (800) 851-3821  
Fax (800) 315-9225

#### MICHIGAN

\*COMMERCIAL GROUP  
9955 Grand River  
Detroit MI 48204  
(313) 931-6100 or (800) 931-7701  
Fax (313) 491-1753

#### \*\*CONTINENTAL CRANE & SERVICE CO.

33681 Groesbeck Hwy.  
Fraser MI 48026  
(810) 293-3870 Fax (810) 293-0017

#### \*\*STEWART ENGINEERING & SALES

2140 Aurora Ave.  
Muskegon MI 49442  
(616) 767-2140 Fax (616) 767-2233

#### MINNESOTA

\*\*ELECTRIC MOTOR REPAIR, INC.  
2010 N. 4th St.  
Minneapolis MN 55411  
(612) 522-3318 or (800) 345-0198  
Fax (612) 588-1617

#### \*\*J & B EQUIPMENT

8200 Grand Avenue South  
Bloomington MN 55420  
(612) 884-2040 Fax (612) 346-1139

#### \*\*\*PERFECTION CRANE & HOIST INC.

201 DeGraff Ave.  
Swanville MN 56382  
(320) 547-2401 or (800) 253-6829  
Fax (800) 353-2254

#### \*\*TOTAL TOOL SUPPLY

315 N. Pierce St.  
St. Paul MN 55104  
(612) 646-4055 or (800) 444-4899  
Fax (612) 646-8610

#### MISSOURI

\*\*HERTZ EQUIPMENT RENTAL & SUPPLY  
800 E. 18th St.  
Kansas City MO 64108  
(816) 221-7788 or (800) 669-7788  
Fax (816) 221-0817

#### \*\*HANDLING SYSTEMS INC.

11678 Gravois Rd.  
St. Louis MO 63126  
(314) 842-7263 Fax (314) 842-5041

#### \*\*ZELLER ELECTRIC

4250 Hoftmeister  
St. Louis MO 63125  
(314) 638-9641 (Outside MO (800) 530-5810)  
Fax (314) 638-6318

#### MONTANA

\*\*INDUSTRIAL TOOL & REPAIR  
2123 2nd Ave. N.  
Billings Montana 59101  
(406) 252-8114 or (800) 823-8665  
Fax (406) 259-3956

UNITED STATES

**NEW JERSEY**

\*\*SISSCO  
186 Route 206 South  
Sommerville NJ 08876  
(908) 359-9767 or (800) 392-0146  
Fax (908) 359-9773

**NEW YORK**

\*\*ABC ELECTRIC  
24-25 46th Street.  
Long Island City NY 11103  
(718) 956-0000 or (N.Y. only-800-562-1919)  
FAX (718) 956-4455

\*\*BEATON INDUSTRIAL, INC.  
6083 Trenton Rd.  
Utica NY 13502  
(315) 797-9346 (N.Y. only-800-724-4052)  
Fax (315) 797-9321

\*\*VOLLAND ELECTRIC EQUIPMENT CO.  
75 Innsbruck Drive  
Buffalo NY 14227  
(716) 656-9900 Fax (716) 656-8899

**NORTH CAROLINA**

\*\*CAROLINA HOIST  
3310 E. Wendover Avenue  
Greensboro NC 27405  
(336) 375-6050 or (800) 326-3655  
Fax (336) 375-6053

\*\*SOUTHERN ELECTRIC SERVICE  
2225 Freedom Drive  
Charlotte NC 28266  
(704) 372- 4832 or (800) 487-3726  
Fax (704) 342-2604

**OHIO**

\*\*CRANE AMERICA - H. W.HOUSE  
920 Deneen Avenue  
Monroe OH 45050  
(513) 539-9770 or (800) 331-5326  
Fax (513) 539-9577

\*\*AMERICRANE & HOIST CORP.  
13224 Enterprise Avenue  
Cleveland OH 44135  
(216) 267-9100 or (800) 652-1932  
Fax (216) 267-9131

\*SAMSEL SUPPLY CO.  
1285 Old River Road  
Cleveland OH 44113  
(216) 241-0333 or (800) 892-8012  
Fax (216) 241-3426

**OKLAHOMA**

\*\*GAFFEY INC.  
6951 E.12th Street  
Tulsa OK 74112  
(918) 836-6827 or (800) 331-3916  
Fax (918) 835-6138

**OREGON**

\*\*GENERAL TOOL & SUPPLY CO.  
2705 N.W. Nicolai  
Portland OR 97210  
(503) 226-3411 or (800) 783-3411  
Fax (503) 778-5518

**PENNSYLVANIA**

\*\*GLOBE ELECTRIC CO.  
200 23rd Street  
Pittsburgh PA 15215  
(412) 781-2677 or (800) 850-4440  
Fax (412) 781-1812

\*KEYSTONE CRANE & HOIST CO.  
861 S. Washington Road  
McMurray PA 15317  
(724) 746-5080 Fax (724) 746-5082

**PENNSYLVANIA (cont'd)**

\*\*MCDAL CORP.  
475 East Church Road  
King of Prussia PA 19406  
(610) 277-5484 or (800) 626-2325  
Fax (610) 277-4690

\*\*REPAIR UNLIMITED  
1730 Rockwell Road  
Abington PA 19001  
(215) 657-3335 or (800) 369-5891  
Fax (215) 784-0343

**RHODE ISLAND**

\*\*MOTORS , HOIST & CONTROLS INC.  
179 Railroad Street  
Woonsocket RI 02895  
(401) 767-4568 Fax (401) 767-4567

**SOUTH CAROLINA**

\*\*ENGINEERED SYSTEMS, INC.  
1121 Duncan-Reidville Road  
Duncan SC 29334  
(864) 879-7438 or (800) 879-7438  
Fax (864) 848-3143

**TENNESSEE**

\*\*HOIST & CRANE CO.  
2508 Perimeter Place  
Nashville TN 37214  
(615) 242-3383 Fax (615) 255- 4379

\*\*HI-SPEED ELECTRICAL CO.

3013 Thomas Street  
Memphis TN 38127  
(901) 357-6231 Fax (901) 357-6238

**TEXAS**

\*\*ABEL EQUIPMENT CO., INC.  
3710 Cavalier Drive  
Garland TX 75042  
(972) 272-7706 Fax (800) 272-2235

\*\*GAFFEY, INC.  
4301 Garland Drive  
Ft. Worth TX 76117  
(817) 281-1994 or (800) 284-4233  
Fax (817) 581-7831

\*\*GAFFEY, INC.  
4003 S. County Road 1297  
Odessa TX 79765  
(915) 563-2897 or (800) 733-0006  
Fax (915) 563-4703

\*\*GAFFEY, INC.  
1436 N. Duck Creek Road  
Cleveland TX 77327  
(281) 443-6690 or (800) 233-8179  
Fax (281) 592-6984

\*\*HYDRAULIC EQUIPMENT SER.  
1021 N. San Jacinto Street  
Houston TX 77002  
(713) 228-4073 Fax (713) 228-0931

\*INDUSTRIAL HOIST SERVICES  
Rt. 4 - 1100 South Brooks  
Brazoria TX 77422  
(409) 798-7077 or (800) 766-7077  
Fax (409) 798-1963

**UTAH**

\*\*ROCKY MOUNTAIN WIRE ROPE & RIG.  
2421 South 2570 West  
Salt Lake City UT 84119  
(801) 972-4972 or (800) 615-3193  
Fax (801) 974-0621

**VIRGINIA**

\*\*FOLEY MATERIAL HANDLING CO.  
11327 Va. Crane Drive  
Ashland VA 23005  
(804) 798-1343 Fax (804) 798-7843

**WASHINGTON**

\*\*B & J INDUSTRIAL SUPPLY  
5601 1st Avenue S.  
Seattle WA 98108  
(206) 762-4430 or (800) 767-4430  
Fax (206) 762-5329

**WISCONSIN**

\*\*ALFERI INDUSTRIAL SALES & SERVICE  
346 Smith Street  
Neenah WI 54956  
(920) 722-6483 Fax (920) 722-6489

\*LIFT INC.

6667 W. Mill Road  
Milwaukee WI 53218  
(414) 353-5353 or (800) 728-5438  
Fax (414) 353-4444

\*TRESTER HOIST & EQUIPMENT

4465 124th Street Unit C  
Brookfield WI 53005  
(262) 790-0700 or (800) 234-6098  
Fax (262) 790-1009

CANADA

**ALBERTA**

\*KRISTIAN ELECTRIC  
4215-64 Avenue SE  
Calgary Alberta T2C 2C8  
(403) 292-9111

**BRITISH COLUMBIA**

\*\*\*AIR BRAKE REPAIR  
144 W. 5th Avenue  
Vancouver British Columbia V5Y 1H7  
(604) 879-7754

**MANITOBA**

\*\*\*B & B DYNAMO  
575 McTavish Street  
Winnipeg Manitoba R2J 2W5  
(204) 237-6066

**ONTARIO**

\*\*TORONTO ELECTRIC  
72 Crockford Blvd  
Scarborough Ontario M1R 3C4  
(416) 755-7716

\*\*PRO-CRANE HOIST REPAIRS INC.

2050 Speers Road, Unit 2  
Oakville Ontario L6L 2X8  
(905) 825-2586

**QUEBEC**

\*\*LEGER  
7995 17th Avenue  
Montreal Quebec H1Z 5R2  
(514) 376-3050

\*\*UPTOWN LtEE  
460 Hubert Street  
Laval Quebec H7G 2Y9  
(514) 667-1859

\*PARTS DEPOT & REPAIR CENTERS

\*\*PARTS DEPOT & WARRANTY REPAIR CENTER

\*\*\*PARTS DEPOT

# COFFING® HOISTS

## LIFETIME WARRANTY

Every hoist is thoroughly inspected and tested prior to shipment from the factory. Should any problems develop, return the complete hoist prepaid to your nearest Coffing® Authorized Warranty Repair Station. If inspection reveals that the problem is caused by defective workmanship or material, repairs will be made without charge and the hoist will be returned, transportation prepaid.

This warranty does not apply where:

- (1) deterioration is caused by normal wear, abuse, improper or inadequate power supply, eccentric or side loading, overloading, chemical or abrasive actions, improper maintenance or excessive heat;
- (2) problems resulted from repairs, modifications

or alterations made by persons other than factory or Coffing® Authorized Warranty Repair Station personnel; (3) the hoist has been abused or damaged as a result of an accident; (4) repair parts or accessories other than those supplied by Coffing® are used on the hoist. Equipment and accessories not of the seller's manufacture are warranted only to the extent that they are warranted by the manufacturer.

**EXCEPT AS STATED HEREIN, COFFING HOISTS® MAKES NO OTHER WARRANTIES, EXPRESSED OR IMPLIED, INCLUDING WARRANTIES OF MERCHANTABILITY AND FITNESS FOR A PARTICULAR PURPOSE.**

### **WARNING**

**Alterations or modifications of equipment and use of non-factory repair parts can lead to dangerous operation and injury.**

**TO AVOID INJURY:**

- Do not alter or modify equipment
- Do not use equipment to lift, support or otherwise transport people
- Do not suspend unattended loads over people

### COFFING® HOISTS

Country Club Road • P.O. Box 779  
Wadesboro, NC 28170 U.S.A  
Phone 800-477-5003 • 704-694-2156  
Fax 800-374-6853

*Authorized Sales & Service*  
**J. HERBERT CORPORATION**  
Call 1-800-255-0588  
407-846-0588 Fax: 846-1066  
info@jherbertcorp.com

**Visit us online:**  
[www.jherbertcorp.com](http://www.jherbertcorp.com)