



Authorized Sales & Service
J. HERBERT CORPORATION
 Call 1-800-255-0588
 407-846-0588 Fax: 846-1066
 info@jherbertcorp.com

Visit us online:
www.jherbertcorp.com

J-904L SERIES

FOUNDATIONLESS BASE MOUNT JIB CRANE

CAPACITY UP TO 1000 LBS.

The Abell-Howe J-904L Series was developed to be a Foundationless jib for light duty industrial applications requiring only 6" concrete depth.

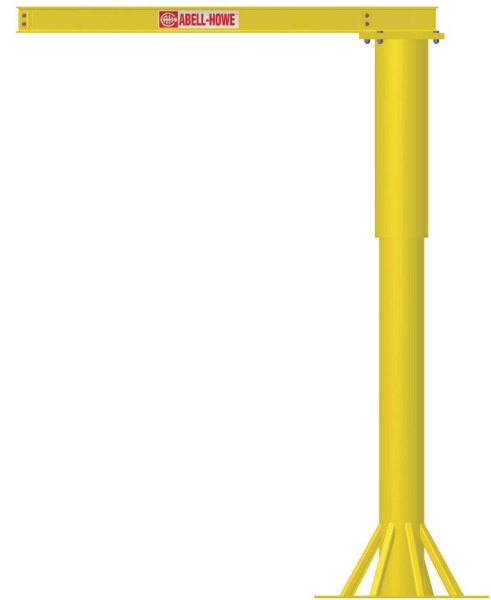

BENEFITS & FEATURES

CAPACITIES

500 & 1,000 lbs.
 Boom Lengths up to 16 ft.
 Under Boom Height from 8 to 14 ft.

SPECIFICATIONS

360 Degree Rotation on a Tapered Roller bearing providing full capacity vertical and radial thrust loading.

Lower section of the head revolves around the pillar on a pair of cam rollers.

Fully enclosed cam rollers to avoid pinch points.

Base plate is reinforced with heavy steel gussets for continuous alignment and rigidity.

Top head assembly can be shimmed for boom leveling.

End stops at both ends of the boom to limit trolley travel.

COMPONENT MATERIAL

Mast - Fabricated from heavy wall structural steel pipe with wall thickness sized to minimize deflection.

Boom - W-beam section.

Head section - Heavy duty pipe section with greased top bearing

OPTIONAL ACCESSORIES

Top entry air swivel or electric collector rings.

Rotational stops.

Anchor Bolts with Template.

Galvanizing/Custom paint finishes.

Messenger wire assembly.



J-904L FOUNDATIONLESS BASE MOUNT JIB CRANE

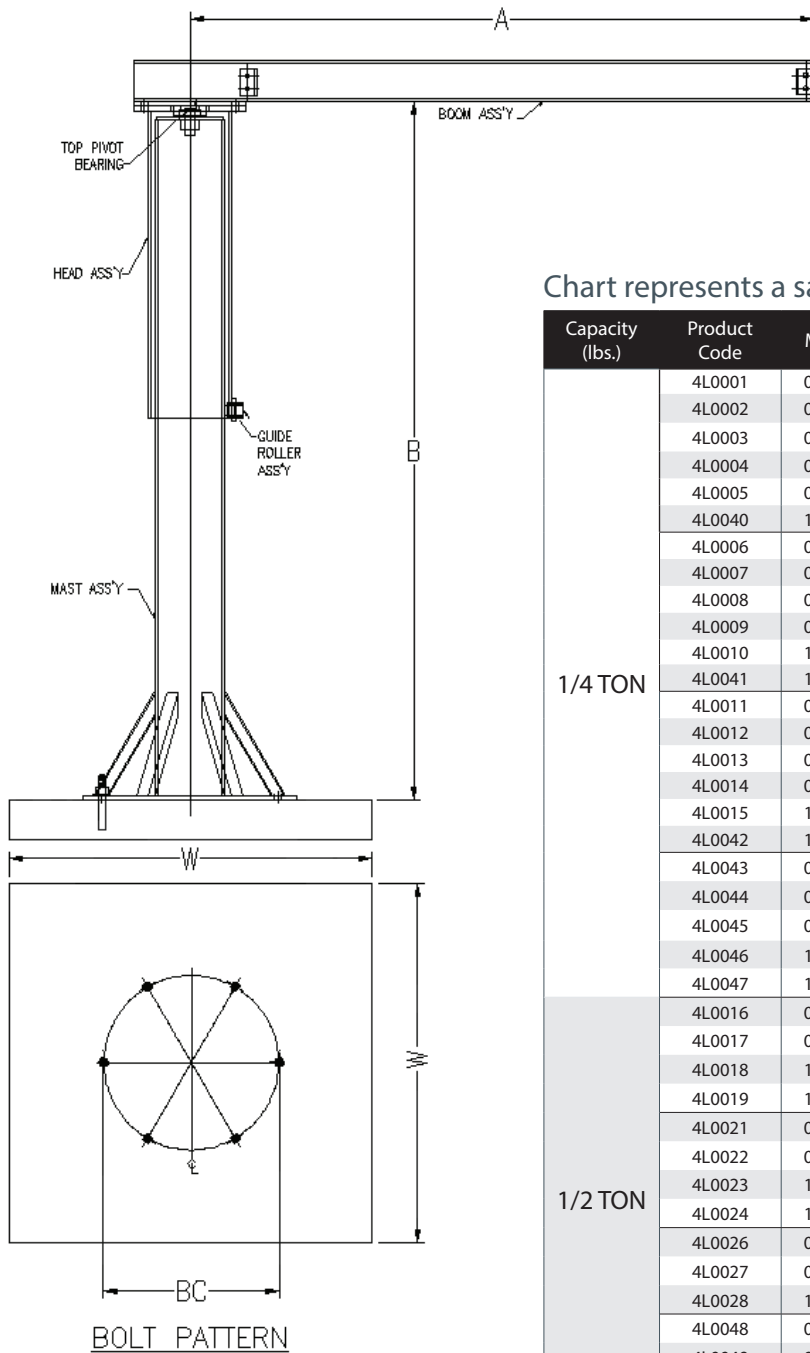

Chart represents a sample of J-904L Sizes & Capacities

Capacity (lbs.)	Product Code	Model #	Span (A)	Boom Height (B)	Base Column (BC)	Slab Size (W)
1/4 TON	4L0001	080-W06	6'-0"	8'-0"	2'-0"	5'-0" x 5'-0"
	4L0002	080-W06	8'-0"	8'-0"	2'-0"	5'-0" x 5'-0"
	4L0003	080-W06	10'-0"	8'-0"	2'-0"	5'-6" x 5'-6"
	4L0004	080-W06	12'-0"	8'-0"	2'-0"	6'-0" x 6'-0"
	4L0005	080-W08	14'-0"	8'-0"	2'-0"	6'-6" x 6'-6"
	4L0040	100-W08	16'-0"	8'-0"	2'-3"	7'-0" x 7'-0"
	4L0006	080-W06	6'-0"	10'-0"	2'-0"	5'-0" x 5'-0"
	4L0007	080-W06	8'-0"	10'-0"	2'-0"	5'-0" x 5'-0"
	4L0008	080-W06	10'-0"	10'-0"	2'-0"	5'-6" x 5'-6"
	4L0009	080-W06	12'-0"	10'-0"	2'-0"	6'-0" x 6'-0"
	4L0010	100-W08	14'-0"	10'-0"	2'-3"	6'-6" x 6'-6"
	4L0041	100-W08	16'-0"	10'-0"	2'-3"	7'-0" x 7'-0"
	4L0011	080-W06	6'-0"	12'-0"	2'-0"	5'-0" x 5'-0"
	4L0012	080-W06	8'-0"	12'-0"	2'-0"	5'-0" x 5'-0"
	4L0013	080-W06	10'-0"	12'-0"	2'-0"	5'-6" x 5'-6"
	4L0014	080-W06	12'-0"	12'-0"	2'-3"	6'-0" x 6'-0"
	4L0015	100-W08	14'-0"	12'-0"	2'-3"	6'-6" x 6'-6"
	4L0042	100-W08	16'-0"	12'-0"	2'-3"	7'-0" x 7'-0"
	4L0043	080-W06	6'-0"	14'-0"	2'-0"	5'-0" x 5'-0"
	4L0044	080-W06	8'-0"	14'-0"	2'-0"	5'-0" x 5'-0"
	4L0045	080-W06	10'-0"	14'-0"	2'-0"	5'-6" x 5'-6"
4L0046	100-W06	12'-0"	14'-0"	2'-3"	6'-0" x 6'-0"	
4L0047	100-W08	14'-0"	14'-0"	2'-3"	6'-6" x 6'-6"	
1/2 TON	4L0016	080-W06	6'-0"	8'-0"	2'-0"	6'-6" x 6'-6"
	4L0017	080-W06	8'-0"	8'-0"	2'-0"	6'-6" x 6'-6"
	4L0018	100-W06	10'-0"	8'-0"	2'-3"	7'-0" x 7'-0"
	4L0019	100-W08	12'-0"	8'-0"	2'-3"	7'-6" x 7'-6"
	4L0021	080-W06	6'-0"	10'-0"	2'-0"	6'-6" x 6'-6"
	4L0022	080-W06	8'-0"	10'-0"	2'-0"	6'-6" x 6'-6"
	4L0023	100-W06	10'-0"	10'-0"	2'-3"	7'-0" x 7'-0"
	4L0024	100-W08	12'-0"	10'-0"	2'-3"	7'-6" x 7'-6"
	4L0026	080-W06	6'-0"	12'-0"	2'-0"	6'-6" x 6'-6"
	4L0027	080-W06	8'-0"	12'-0"	2'-0"	6'-6" x 6'-6"
	4L0028	100-W06	10'-0"	12'-0"	2'-3"	7'-0" x 7'-0"
	4L0048	080-W06	6'-0"	14'-0"	2'-0"	6'-6" x 6'-6"
	4L0049	080-W06	8'-0"	14'-0"	2'-0"	6'-6" x 6'-6"
4L0050	100-W06	10'-0"	14'-0"	2'-3"	7'-0" x 7'-0"	

CONCRETE FLOOR NOTES:

Minimum soil pressure of 2,500 psf.

Minimum concrete compressive strength of 3,000 psi.

Concrete floor must be at least 6" thick and contain wire mesh reinforcement.

Jib crane must be centered on a square foot area that is free of cracks, seams control joints and walls.