

Sheet Lifters

Model 60M - Motorized Heavy Duty Sheet Lifters



Special 10 ton unit with extended bundle height.

PRODUCT FEATURES:

- Versatile handling of bundles, sheets, plates and other materials stacked horizontally.
- Low headroom design for optimum lifting capabilities.
- One person operation minimizes handling cost.
- Self-locking worm gear drive for leg adjustment is standard.
- Easy adjustment for different sheet widths.
- Motorized leg adjustment, 460 volt.
- Rack and pinion leg drive.
- Designed for ease of maintenance.
- Broad adjustment range handles various load widths.
- Complies with ASME standards.

PRODUCT OPTIONS:

- Battery powered motorization.
- End chains with plate hooks (recommended for all widths 72" and greater).
- Extended grab shoe lengths.
- Longer legs increase load clearance.
- Controls shipped mounted or loose.
- Other voltages available.

Bail Opening

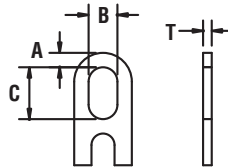

Authorized Sales & Service
J. HERBERT CORPORATION
 Call 1-800-255-0588
 407-846-0588 Fax: 846-1066
 info@jherbertcorp.com
 Visit us online:
www.jherbertcorp.com

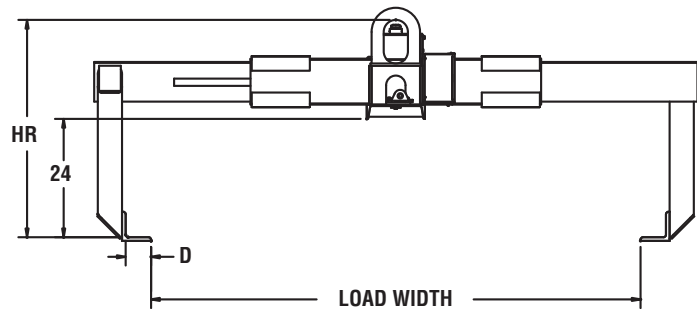
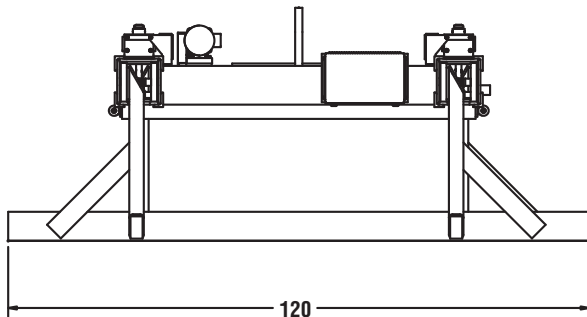

SPECIFICATIONS

Model Number	Capacity (tons)	Dimensions (inches)										Weight (lbs.)
		Load Width		HR Headroom	Shoe D	Min. Aisle	Bail Opening					
		Min.	Max.				A	B	C	T		
60M-20-96	20	38	96	45	5.25	15	2.5	5	9	1.5	3150	

Other sizes available, consult factory.

⚠ WARNING

Do not lift loosely bundled, thin or oily sheets.