

mansaver®

- **Balanced C-Frame Fork Lifters for any application**
- **Designed for safety and ease of use**
- **Available in any required load capacity**

G1274M C-Frame Fork Lifters

G1274M C-FRAME FORK LIFTERS

Mansaver® offers G1274M balanced fork lifters both in standard and custom designed configurations to meet the specific requirements of your application.

All ACCO C-Hooks conform to ASME B30.20 specifications for below-the-hook lifting devices. Standard paint is ACCO safety yellow machine enamel.

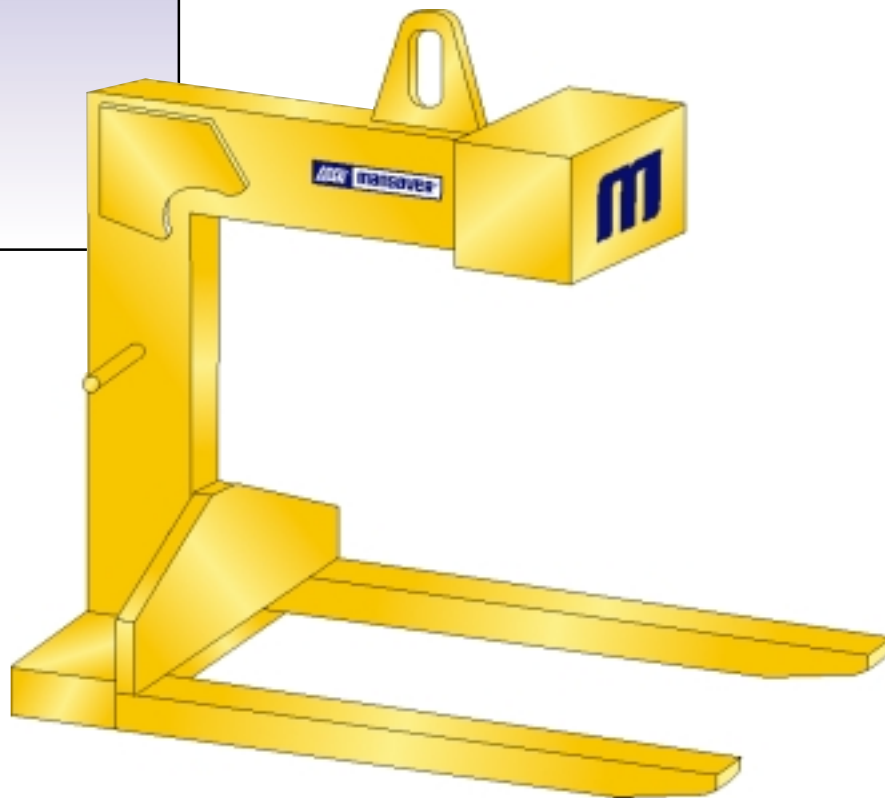

- **Standard pallet style lifter with fixed forks**

Authorized Sales & Service
J. HERBERT CORPORATION
Call 1-800-255-0588
407-846-0588 Fax: 846-1066
info@jherbertcorp.com

Visit us online:
www.jherbertcorp.com

ACCO® 8.2.1

mansaver[®]

"The Lifting Power You Need."

G1274M C-Frame Fork Lifters

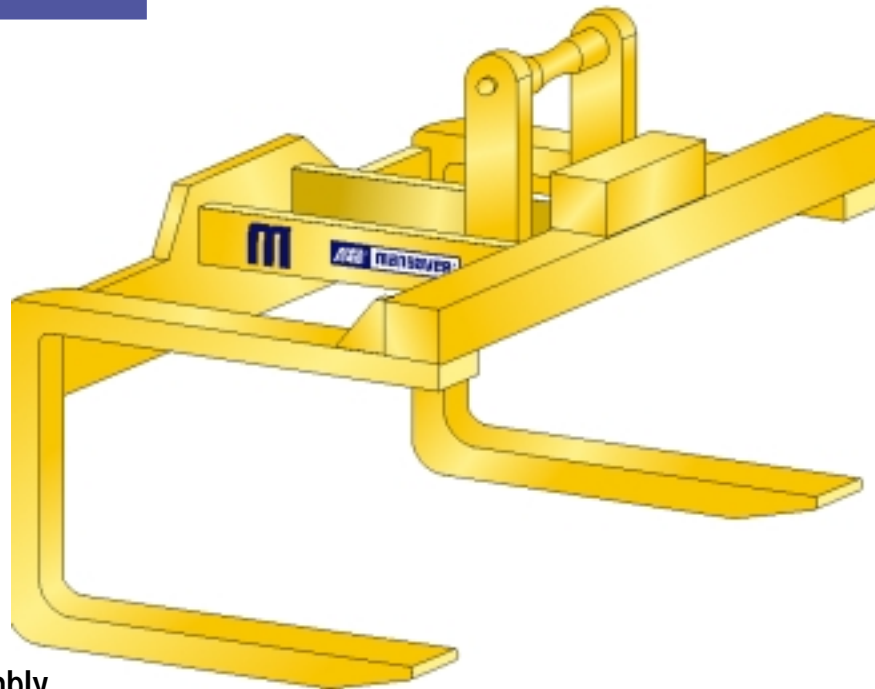

- Widely spaced forks for bundle handling
- Pivoting bail assembly

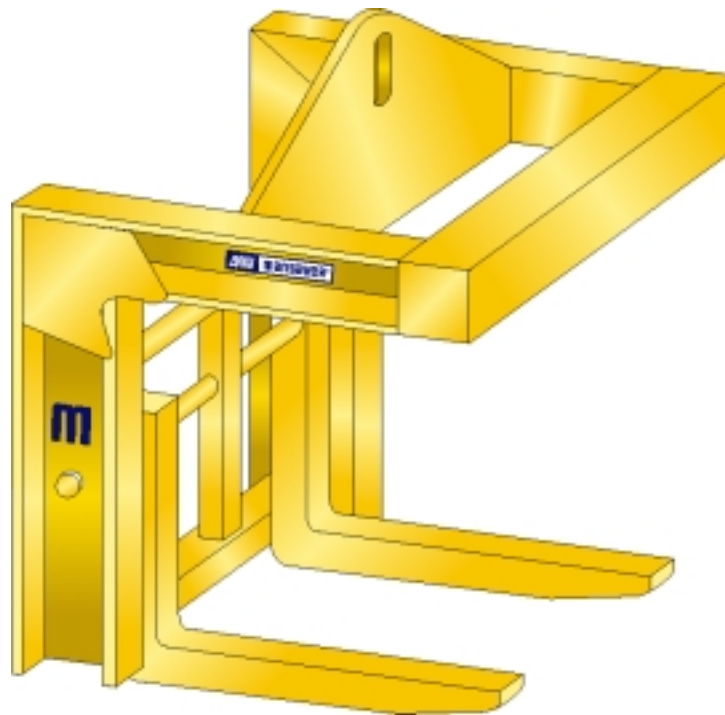

- High capacity lifter with manual fork spread adjustment

8.2.2 **ACCO**[®]

Authorized Sales & Service
J. HERBERT CORPORATION
Call 1-800-255-0588
407-846-0588 Fax: 846-1066
info@jherbertcorp.com

Visit us online:
www.jherbertcorp.com

© 2000 FKI Industries Inc. 6991-0018 JGD 2M 0600 Printed in U.S.A.

mansaver[®]

"The Lifting Power You Need."

G1274M C-Frame Fork Lifters

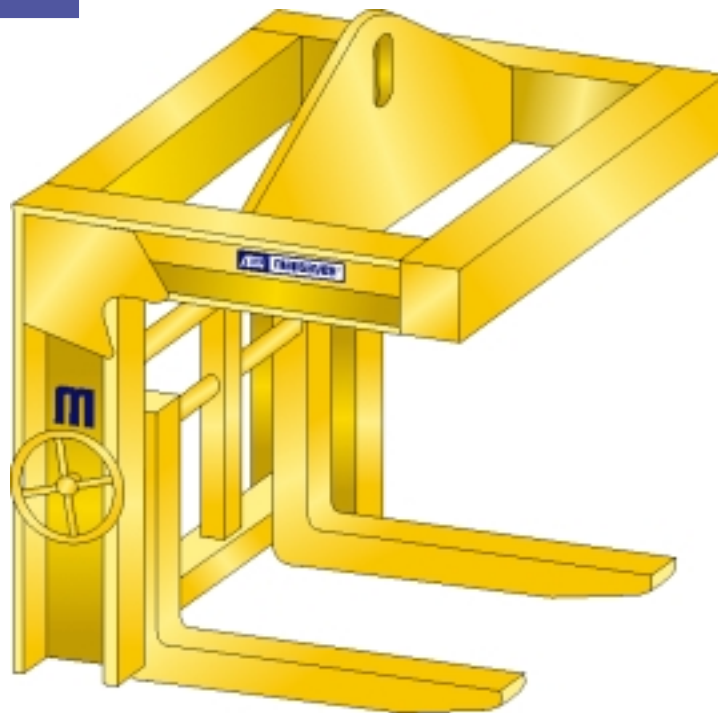

- High capacity lifter with screw driven fork spread adjustment

Authorized Sales & Service

J. HERBERT CORPORATION

Call 1-800-255-0588
407-846-0588 Fax: 846-1066
info@jherbertcorp.com

Visit us online:
www.jherbertcorp.com

ABCO[®] 8.2.3

G1274M C-Frame Fork Lifters

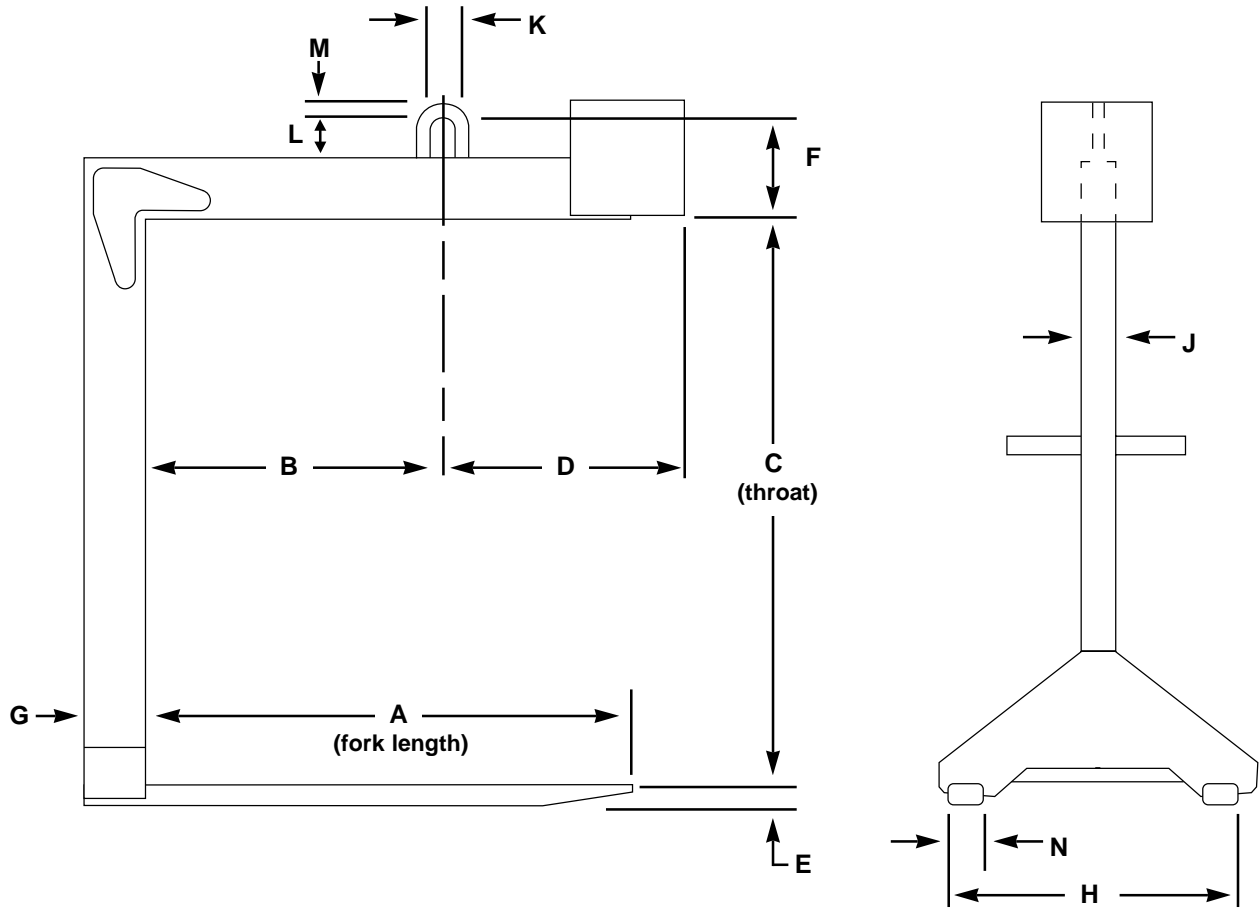

Cap.	Pallet Size	Wt.	A	B	C	D	E	F	G	H	J	K	L	M	N	Catalog No.
1 Ton	36	445	31	19	36	15	2	9	5.25	25	3	1.5	4	1	3	A106885
	48	555	42	25	48	21	2	9	5.25	25	3	1.5	4	1	3	A106881
2 Ton	36	650	31	19	36	15	2	12	6.25	25	4	2.5	6	1.5	4.5	A106886
	48	800	42	25	48	21	2	12	6.25	25	4	2.5	6	1.5	4.5	A106882
3 Ton	36	850	31	19	36	15	2	13	7.25	25	5	2.5	6	1.5	5	A106887
	48	1100	42	25	48	21	2	13	7.25	27	5	2.5	6	1.5	5	A106883
5 Ton	36	1440	31	19	36	15	2.5	18	10.37	25	6	3	8	2	5	A106888
	48	1740	42	25	48	21	2.5	18	10.37	30	6	3	8	2	5	A106884

Note: all dimensions shown are in inches and are approximate.
 Center of load must be on center line of crane hook before lifting.



G1274M C-Frame Fork Lifters

Selection Guide

All Mansaver® G1274M C-Frame Fork lifters are designed to perform specific lifting tasks in conjunction with other lifting equipment.

The C-Frame Fork lifter examples on the preceding pages and the fill-in tables below are intended to assist in determining what C-Frame Fork design is best suited to your lifting task. Please supply available application information and submit to the Mansaver® sales department for pricing and further assistance in equipment choice.

All ACCO MANSAYER® Products meet or exceed ANSI B.30.20* for "Below The Hook" lifting devices.

All ACCO MANSAYER® Products have a one year warranty on workmanship and materials.**

* Please refer to ANSI Standards B.30.20 and B.30.9 for all lifting applications and guidelines.
** Consult the factory for further details.

LOAD INFORMATION:

Load description (palletized load, bundled load (other): _____

Load dimension or range of dimensions: _____

Available fork space under load: _____

Maximum load weight: _____

C-FRAME FORK LIFTER INFORMATION:

Required lifter capacity: _____

Capacity of the hoist lifter will be used with: _____

Lifter type (fixed or adjustable forks, more than (2) forks, rotating or adjustable bail, other): _____

Required fork centers or range of centers: _____

Options (special paint, special markings, bumpers): _____

Lifting Hoist Hook Information on reverse side

Clear Form

Authorized Sales & Service
J. HERBERT CORPORATION
 Call 1-800-255-0588
 407-846-0588 Fax: 846-1066
 info@jherbertcorp.com

Visit us online:
www.jherbertcorp.com



mansaver[®]

"The Lifting Power You Need."

G1274M C-Frame Fork Lifters

Lifting Hoist Hook Information

(Please Fill Out Completely)

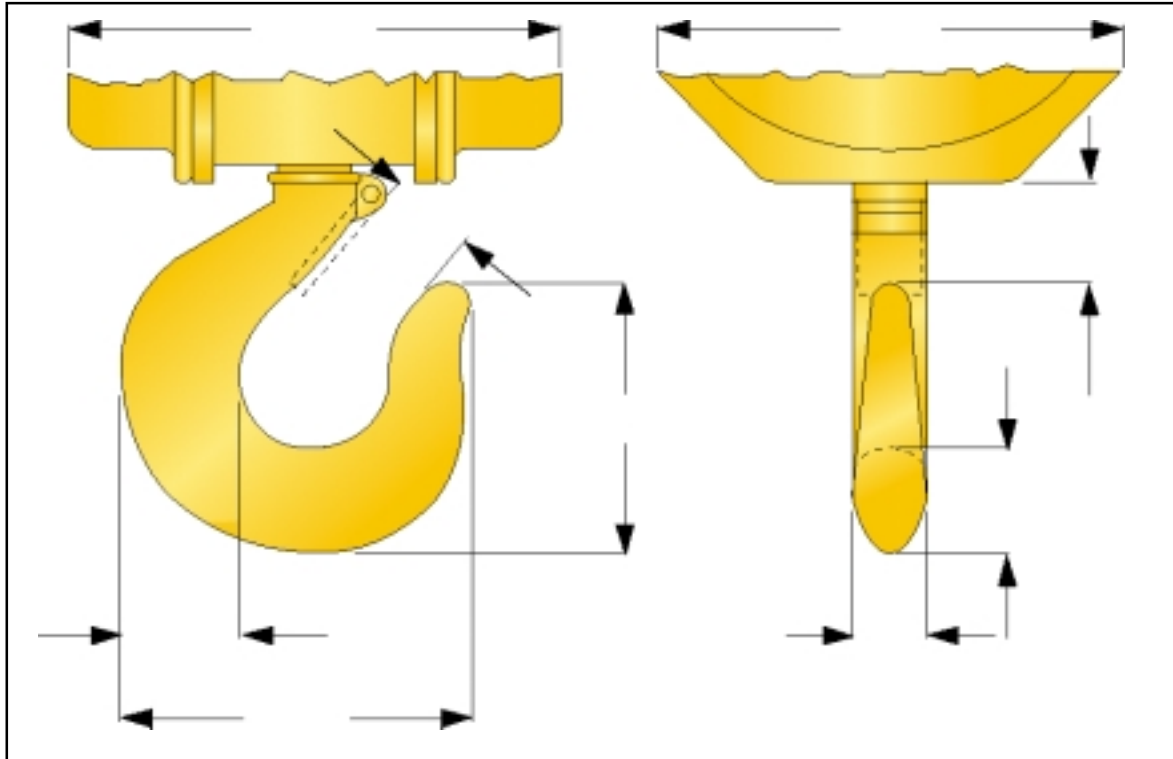

Acco[®] Acco Chain & Lifting Products Division

76 Acco Drive, Box 792, York, PA 17405
Telephone 800-967-7333 Fax 800-715-8897
www.accolifting.com

PART OF THE **FKI** GROUP OF COMPANIES

Acco[®] 8.2.6

Authorized Sales & Service

J. HERBERT CORPORATION

Call 1-800-255-0588
407-846-0588 Fax: 846-1066
info@jherbertcorp.com

Visit us online:
www.jherbertcorp.com