

G1347 J-Hook Beams

- Load and Spreader Beams for any application
- Designed for safety and ease of use
- Available in any required load capacity

G1347 J-HOOK BEAMS

Mansaver® model G1347 lifting beams are used in any application where a “hook-style” method of lifting is required. Rolls of paper, cloth, and other materials are readily handled by their core mandrel or circumference.

G1347 beams are also used to handle containers of all sorts with trunnion shafts, from small scrap bins up to hot metal mill ladles.

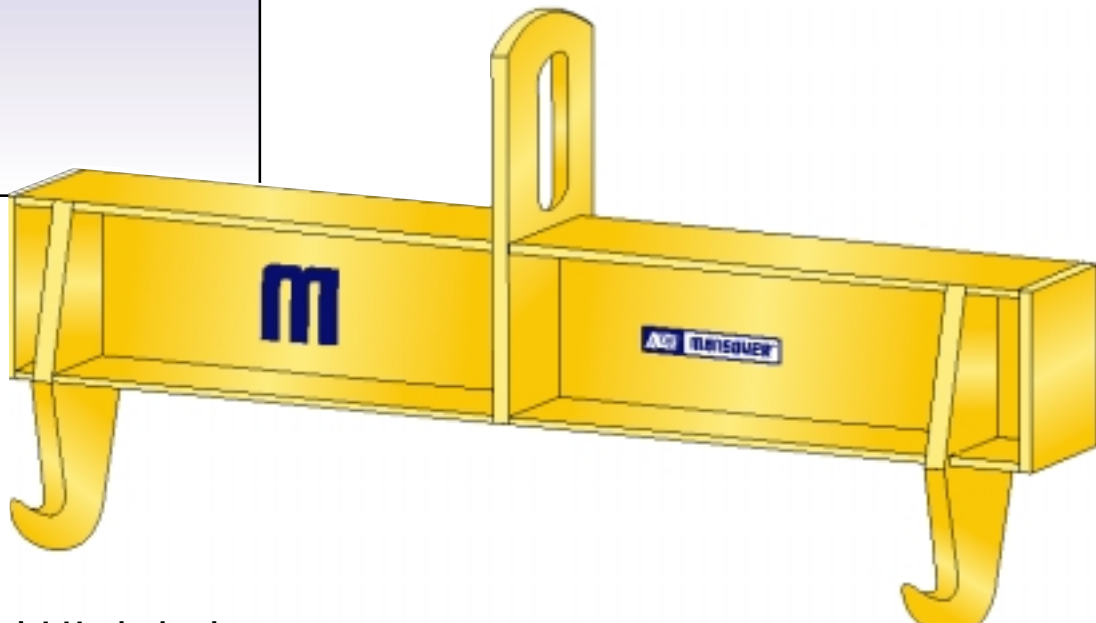

- Fixed J-Hooks hooks
- Fixed plate bail

Authorized Sales & Service
J. HERBERT CORPORATION
Call 1-800-255-0588
407-846-0588 Fax: 846-1066
info@jherbertcorp.com

Visit us online:
www.jherbertcorp.com

mansaver[®]

"The Lifting Power You Need."

G1347 J-Hook Beams

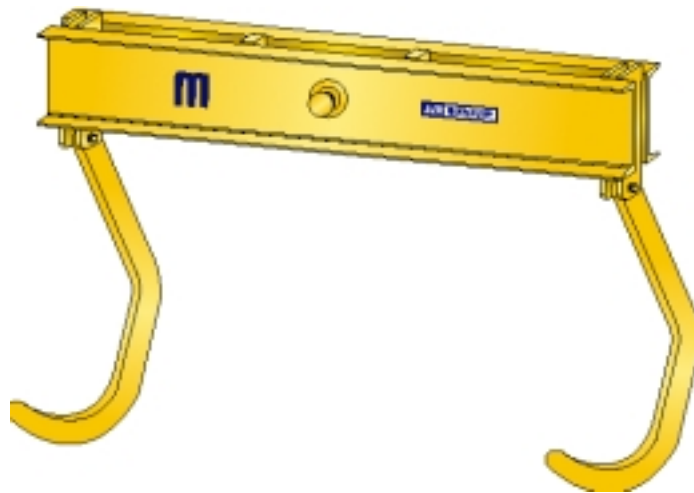

- Large radius J-Hooks for handling rolls by the circumference
- Low headroom, removable recessed bail pin
- Hooks pivot perpendicular to the beam



- Low headroom, removable recessed bail pin
- Hooks pivot in-line with the beam

3.2.2 **ACCO**[®]

Authorized Sales & Service
J. HERBERT CORPORATION
Call 1-800-255-0588
407-846-0588 Fax: 846-1066
info@jherbertcorp.com

Visit us online:
www.jherbertcorp.com

© 2000 FKI Industries Inc. 6991-00018 JGD 2M 0600 Printed in U.S.A.

mansaver[®]

"The Lifting Power You Need."

G1347 J-Hook Beams



- Screw-driven, manually adjustable hook centers
- Motorized adjustment available

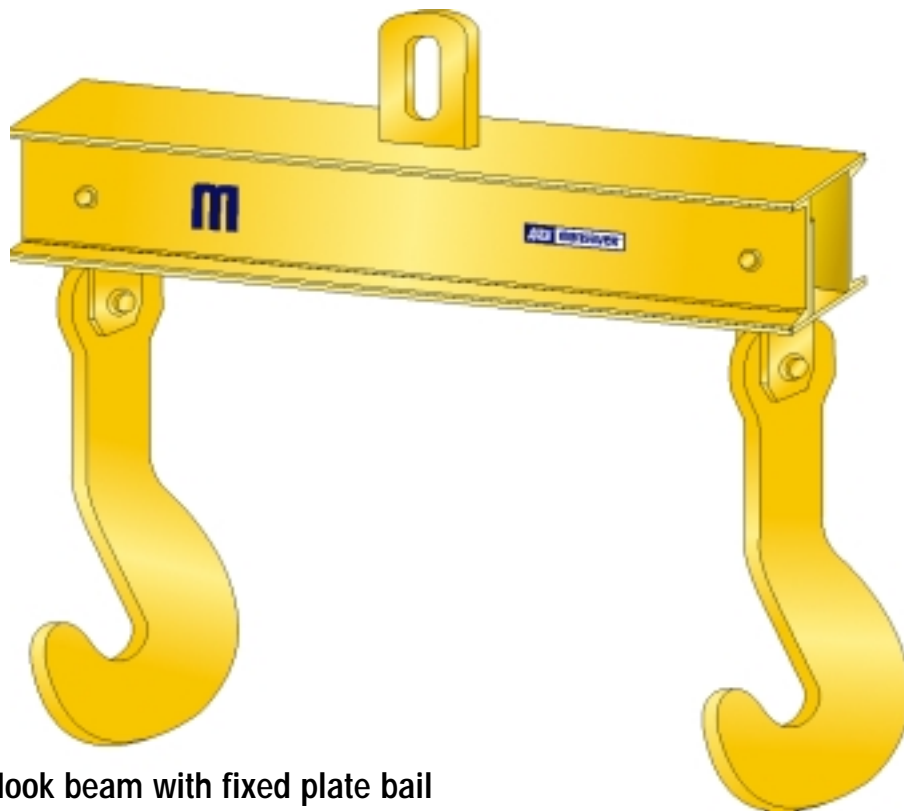

- Heavy ladle J-Hook beam with fixed plate bail
- Hooks pivot perpendicular to the beam
- Sheave suspension, double suspension available

Authorized Sales & Service
J. HERBERT CORPORATION
Call 1-800-255-0588
407-846-0588 Fax: 846-1066
info@jherbertcorp.com

Visit us online:
www.jherbertcorp.com

ABCO[®] 3.2.3

mansaver[®]

"The Lifting Power You Need."

G1347 J-Hook Beams

- Heavy ladle J-Hook beam with powered rotation
- Fixed hooks
- Trunnion suspension

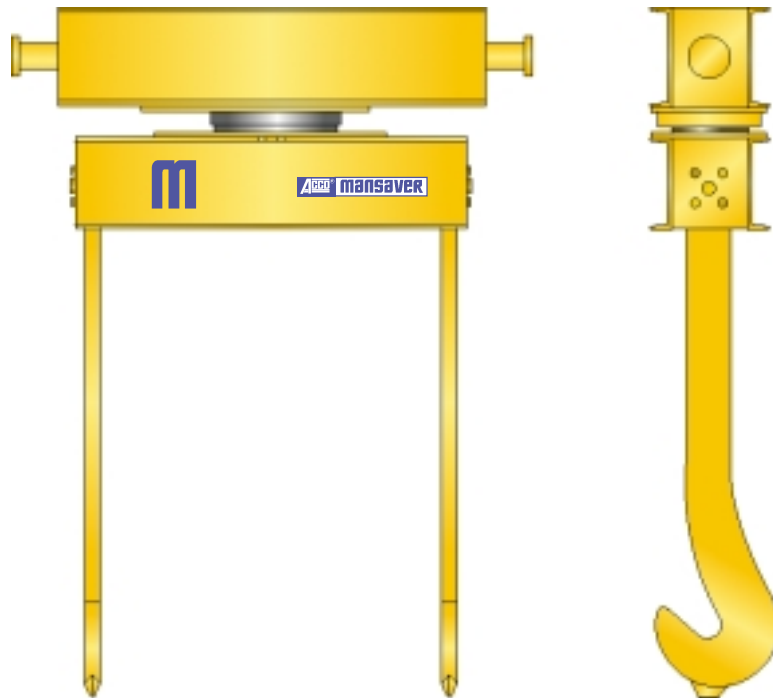

Authorized Sales & Service
J. HERBERT CORPORATION
Call 1-800-255-0588
407-846-0588 Fax: 846-1066
info@jherbertcorp.com
Visit us online:
www.jherbertcorp.com



G1347 J-Hook Beams

Selection Guide

All Mansaver® G1347 J-Hook load and spreader beams are designed to perform specific lifting tasks in conjunction with other lifting equipment.

The J-Hook beam examples on the preceding pages and the fill-

in tables below are intended to assist in determining what lifting beam design is best suited to your lifting task. Please supply available application information and submit to the Mansaver® sales department for

pricing and further assistance in equipment choice.

All ACCO MANSAYER® Products meet or exceed ANSI B.30.20* for "Below The Hook" lifting devices.

All ACCO MANSAYER® Products have a one year warranty on workmanship and materials.**

* Please refer to ANSI Standards B.30.20 and B.30.9 for all lifting applications and guidelines.

** Consult the factory for further details.

LOAD INFORMATION:

Load description (rolls, containers, ladles, other): _____

Lifting point dimensions (shaft or roll diameter): _____

Maximum load weight and size (length, width, diameter, etc.): _____

BEAM INFORMATION:

Required beam capacity: _____

Capacity of the hoist beam will be used with: _____

Beam type (simple, manual or power rotating, adj. hook centers, adj. bail, other): _____

Type of beam suspension (plate bail, removable pin, sheaves, other): _____

Number of beam suspension points (single, double, other): _____

Beam suspension centers (if 2 or more points): _____

(OVER)

Lifting Hoist Hook Information on reverse side

Clear Form

Authorized Sales & Service
J. HERBERT CORPORATION
Call 1-800-255-0588
407-846-0588 Fax: 846-1066
info@jherbertcorp.com
Visit us online:
www.jherbertcorp.com



G1347 J-Hook Beams

J-HOOK INFORMATION:

J-Hook suspension (fixed, pivoting): _____

J-Hook centers or range of centers: _____

Lifting Hoist Hook Information

(Please Fill Out Completely)

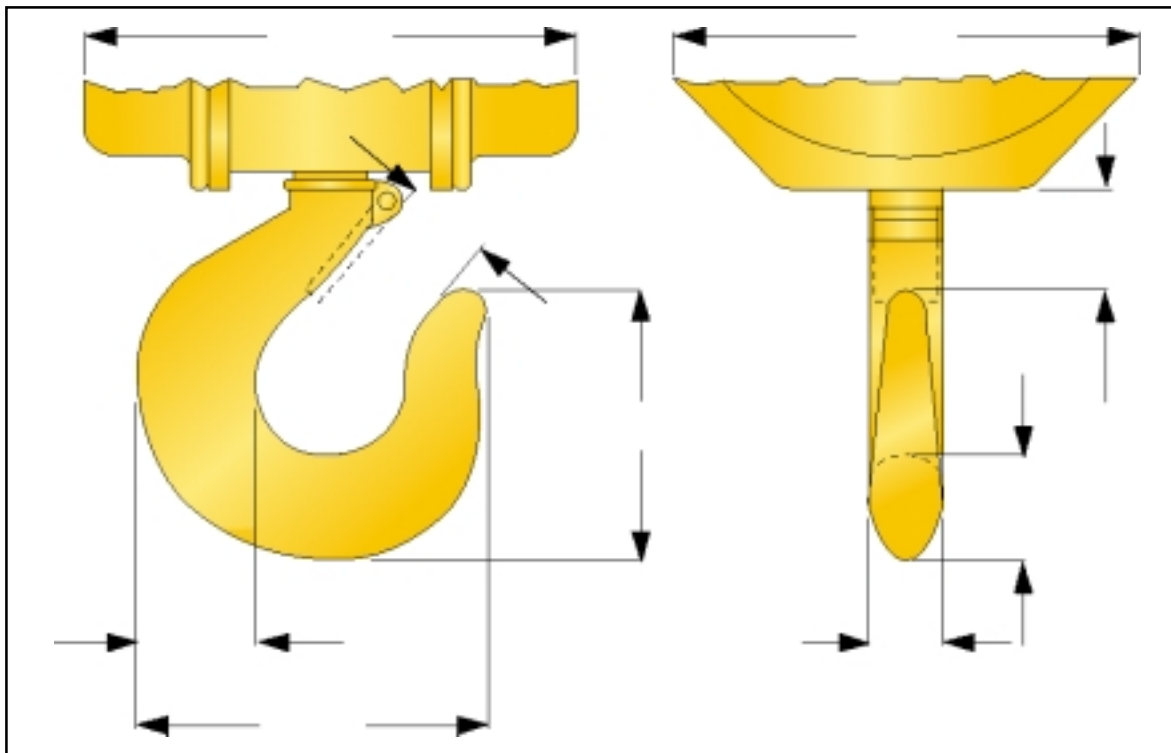

Acco[®] Acco Chain & Lifting Products Division
 76 Acco Drive, Box 792, York, PA 17405
 Telephone 800-967-7333 Fax 800-715-8897
 www.accolifting.com

PART OF THE **FKI** GROUP OF COMPANIES

Acco[®] 3.2.6

Authorized Sales & Service
J. HERBERT CORPORATION
 Call 1-800-255-0588
 407-846-0588 Fax: 846-1066
 info@jherbertcorp.com
 Visit us online:
 www.jherbertcorp.com

Clear Form