





AS Series Certified Spark Resistant Air Hoists with Stainless Steel Components



Harrington's AS Series air hoists are built using materials that will reduce or eliminate risk of spark produced by impact or friction in heavy-duty industrial applications. These hoists are  certified spark resistant (*Explosive atmospheres that require features that reduce the risk of spark) to level  II 2GD c T5 IIC T100°C and are in compliance with the EU ATEX Directive. AS Series hoists are available in ¼ and ½ Ton capacities in either pendant, cord or twist rod control and are also able to operate without lubrication in the air supply where required.

Spark resistant features

-  certified spark resistant to level  II 2GD c T5 IIC T100°C
- Stainless steel load chain
- Stainless steel top and bottom hooks
- Stainless steel hook latches
- Stainless steel hardware

Reliable features

- Heavy-duty disc brake
- Reliable vane motor
- Planetary gearing system
- Lightweight and compact cast aluminum body
- Upper / lower limit switches

Hazardous location examples*

- Petrochemical/chemical processing
- Pharmaceutical processing
- Grain handling, storage and processing
- Paint booths (liquid, powders)

*Consult a qualified person to determine ATEX requirements for specific applications.

Ask your local sales representative or call our Customer Service staff for friendly and expert advice on models and options.

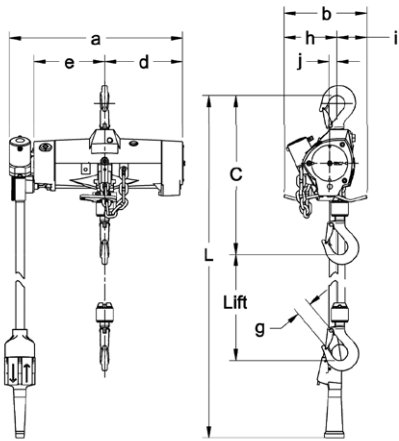

AS005P

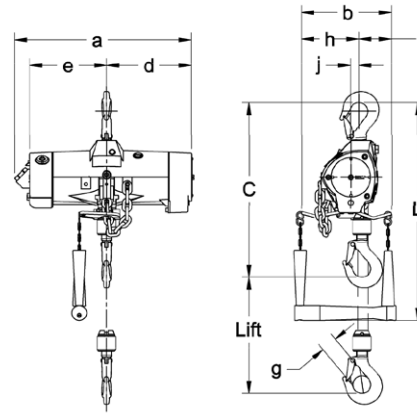

AS005C

AS PENDANT MODEL—SPECIFICATIONS

Cap. (Tons)	Product Code	Standard Lift (ft)	Push Button Hose L (ft)	Up/Down Speeds (ft/min @ 90psi)		Up/Down Air Consumption Rates (cubic ft/min @ 90 psi)		Load Chain Diameter (mm) x Chain Fall Lines	Net Weight (lbs)	Weight for Additional One Foot of Lift (lbs)
				No Load	w/Full Load	No Load	w/Full Load			
1/4	AS003P	10	7.5	85 / 66	61 / 105	98 / 64	78 / 72	6.5x1	39	0.6
1/2	AS005P			78 / 49	41 / 72	102 / 68	81 / 74	6.5x1	39	0.6

AS PENDANT MODEL—DIMENSIONS

Capacity (Tons)	Product Code	Headroom C (in)	a (in)	b (in)	d (in)	e (in)	g (in)	h (in)	i (in)	j (in)
1/4	AS003P	14.8	15.9	7.7	7.2	6.6	1.1	4.8	2.9	0.7
1/2	AS005P	14.8	15.9	7.7	7.2	6.6	1.1	5.1	2.6	1.0

AS CORD MODEL—SPECIFICATIONS

Cap. (Tons)	Product Code	Standard Lift (ft)	Cord L (ft)	Up/Down Speeds (ft/min @ 90psi)		Up/Down Air Consumption Rates (cubic ft/min @ 90 psi)		Load Chain Diameter (mm) x Chain Fall Lines	Net Weight (lbs)	Weight for Additional One Foot of Lift (lbs)
				No Load	w/Full Load	No Load	w/Full Load			
1/4	AS003C	10	7.5	85 / 66	61 / 105	98 / 64	78 / 72	6.5x1	37.5	0.6
1/2	AS005C			78 / 49	41 / 72	102 / 68	81 / 74	6.5x1	37.5	0.6

For optional Twist Rod Control – Rod L = 3.5 to 6.5 feet.

AS CORD MODEL—DIMENSIONS

Capacity (Tons)	Product Code	Headroom C (in)	a (in)	b (in)	d (in)	e (in)	g (in)	h (in)	i (in)	j (in)	k (in)
1/4	AS003C	14.8	15.4	7.7	7.2	6.7	1.1	4.8	2.9	0.7	8.7
1/2	AS005C	14.8	15.4	7.7	7.2	6.7	1.1	5.1	2.6	1.0	8.7



Harrington Hoists, Inc.
 401 West End Avenue, Manheim, PA 17545
 717-665-2000 / 800-233-3010 / Fax: 717-665-2861
 www.harringtonhoists.com

Harrington Hoists, Inc.—Western Division
 2341 Pomona Road, No. 103
 Corona, CA 92880-6973
 951-279-7100 / 800-317-7111 / Fax: 951-279-7500

Specifications and dimensions are subject to change without notice.
 Rev 0 Copyright ©2016 5-16
 Item No. SS-AS